

BRENT Grain Handling

AVALANCHE® DOUBLE-AUGER GRAIN CARTS

MODELS 1196 & 1396

RIGHT-HAND UNLOAD

1196 = Serial Number B42220100 & Higher

1396 = Serial Number B42230100 & Higher

Part No. 295230

Foreword

 This symbol identifies important safety messages. When you see it, read the message that follows and be alert to the possibility of personal injury.

Remember, safety instructions stated in this manual are for your protection. Read them carefully and follow them closely when working around or using this machine.

Read and study this manual completely before attempting to operate this implement. Take this manual to the field for handy reference when operating, adjusting, or servicing your machine.

When referenced, “Right-Hand” (RH) and “Left-Hand” (LH) side of the machine are determined by standing behind the machine and facing in the direction of travel.

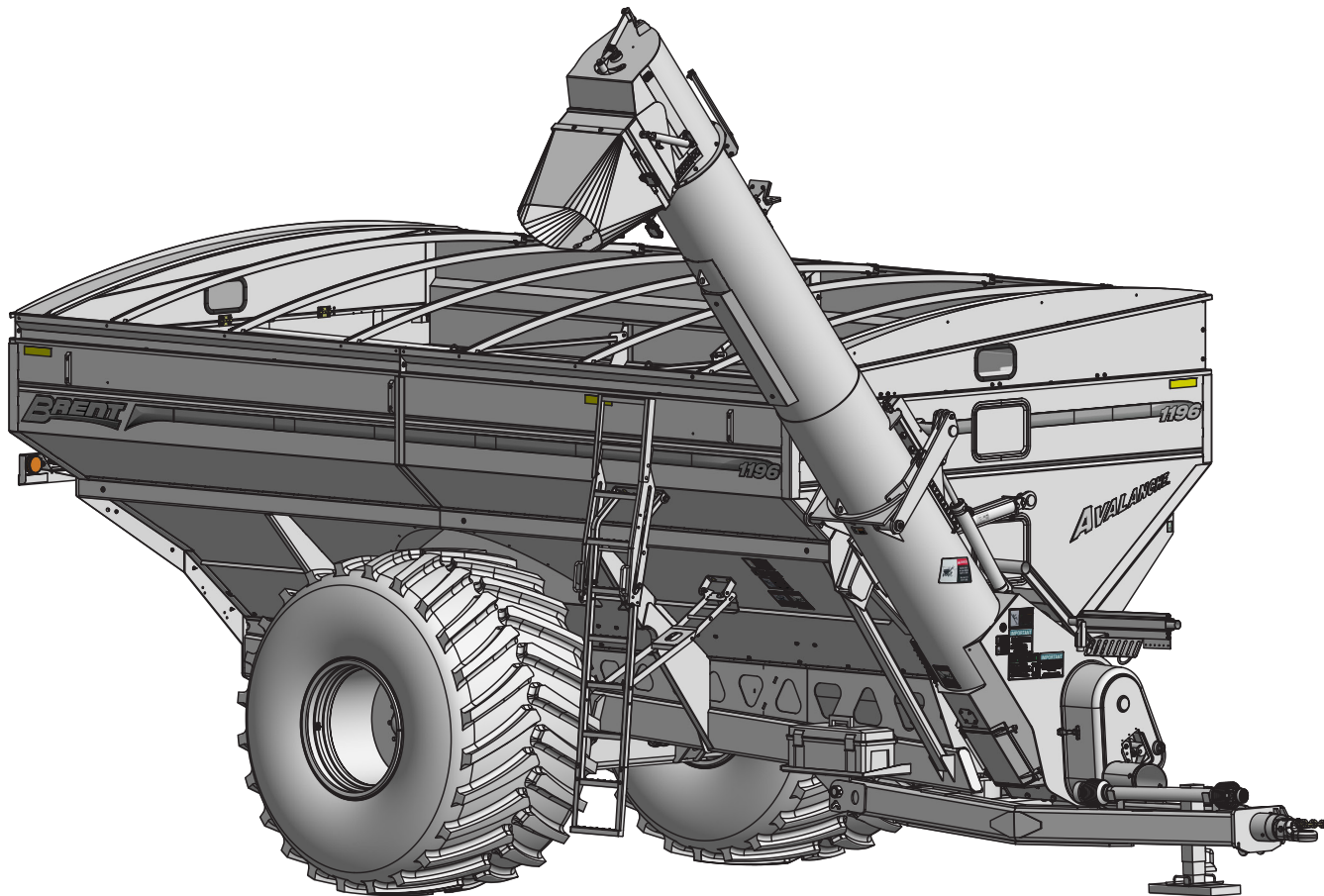

Product Information

When ordering parts or when requesting further information or assistance, always give the following information:

- Machine name
- Model number
- Serial number

All products manufactured by Unverferth Mfg. Co., Inc. are warranted to be free from material and workmanship defects for one full year from time of consumer delivery. Your local dealer will gladly assist you with any warranty questions.

Please fill out and retain this portion for your records.

Purchase Date _____ Model _____ Serial No. _____

Dealer _____ City _____

Dealer Contact _____ Phone _____

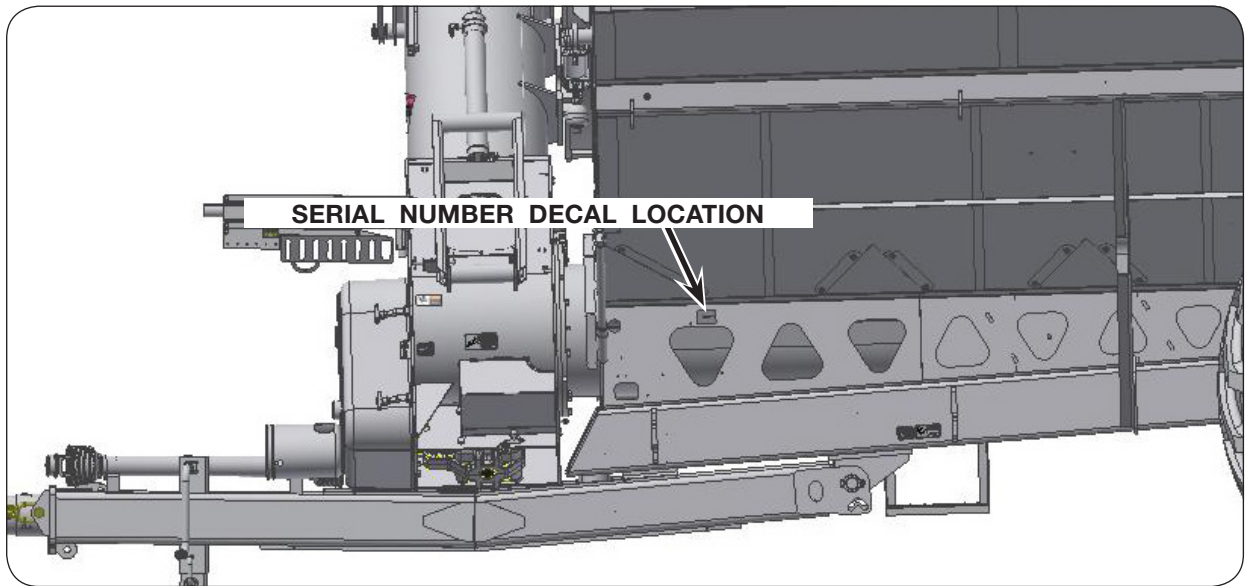

IMPORTANT

- *The information, specifications, and illustrations in the manual are based on information available at the time it was written. Due to continuing improvements in the design and manufacture of Unverferth products, all specifications and information contained herein are subject to change without notice.*

Table of Contents

**Section I
Safety**

General Hazard Information 1-2
 Safety Decals 1-3
 Following Safety Instructions 1-5
 Before Servicing..... 1-5
 Before Operating 1-6
 During Operation 1-6
 Before Transporting 1-6
 During Transport..... 1-7
 Driveline Safety..... 1-8
 Pressurized Oil 1-9
 Preparing for Emergencies..... 1-10
 Wearing Protective Equipment 1-10

**Section II
Set Up**

Set Up Checklist..... 2-2
 Basic Cart Set Up
 Hydraulic System..... 2-3
 Wheel/Tire Set Up 2-3
 Auger Spout Cylinder Stop Removal..... 2-4
 PTO Brackets Removal..... 2-4
 Jack..... 2-5
 Optional Hydraulic Jack..... 2-5
 Driveline Set Up 2-7
 Coupling The Cut-Out Clutch 2-7
 SMV Emblem and SIS Decal 2-8
 Video System (Optional) 2-8
 Upper Ladder Extension to Operating Position..... 2-9
 Horizontal Cleanout Door Inspection 2-10
 Belt Engagement 2-12
 Operational Check 2-13

FOR SCALE INFORMATION, PLEASE REFER TO YOUR SCALE MANUAL.
 FOR TRACK INFORMATION, PLEASE REFER TO YOUR TRACK MANUAL.
 FOR U-HARVEST SCALE INFORMATION, PLEASE REFER TO YOUR U-HARVEST MANUAL.
 FOR ELECTRIC TARP INFORMATION, PLEASE REFER TO YOUR ELECTRIC TARP MANUAL.
 FOR WATER DELIVERY SYSTEM INFORMATION, PLEASE REFER TO YOUR WATER DELIVERY SYSTEM MANUAL.

Table of Contents

**Section III
Operation**

Operating Checklist..... 3-2

Preparing Tractor..... 3-3

Preparing Cart..... 3-3

Lubrication..... 3-4

Video System (Optional)..... 3-4

Hitching to Tractor

 Drawbar Connection 3-5

 Jack Usage..... 3-6

 Optional Hydraulic Jack Usage 3-7

 Transport Chain Connection..... 3-8

 Hydraulic Connections 3-9

 Towing 3-11

 Electrical Connections..... 3-12

Electric Over Hydraulic Operation (Optional) 3-13

Manual Override for Optional Electric Over Hydraulic System 3-16

Vertical & Horizontal Cleanout Door Operation 3-18

 Opening Vertical Cleanout Door 3-18

 Closing Vertical Cleanout Door..... 3-19

 Horizontal Cleanout Door..... 3-20

Auger Operation

 PTO-Driven Auger 3-22

 Auger Overload Procedure..... 3-24

 Vertical Auger Fold..... 3-25

 Auger Field Rest Position..... 3-26

 Auger Transport Position 3-27

 Upper Auger Rest Adjustments 3-28

Troubleshooting..... 3-29

Auger Switch Troubleshooting..... 3-31

Ladder Operation..... 3-32

Weather Guard Tarp..... 3-36

FOR SCALE INFORMATION, PLEASE REFER TO YOUR SCALE MANUAL.
 FOR TRACK INFORMATION, PLEASE REFER TO YOUR TRACK MANUAL.
 FOR U-HARVEST SCALE INFORMATION, PLEASE REFER TO YOUR U-HARVEST MANUAL.
 FOR ELECTRIC TARP INFORMATION, PLEASE REFER TO YOUR ELECTRIC TARP MANUAL.
 FOR WATER DELIVERY SYSTEM INFORMATION, PLEASE REFER TO YOUR WATER DELIVERY
 SYSTEM MANUAL.

Table of Contents

**Section IV
Maintenance**

Lubrication - Cart 4-2

Hydraulic System 4-4

 Purge Hydraulic System 4-4

 Relieving Hydraulic Pressure 4-5

Purging Procedure For EOH System 4-5

Walking Tandem Option 4-6

 Inner Dual Wheel Access 4-6

 Row Spacing Adjustment 4-7

Seasonal Storage 4-8

Gearbox Sight Glass 4-9

Driveline Removal 4-9

 Clamping Cone Assembly 4-9

Auger Driveline Bearings 4-10

Baffle Adjustment 4-11

Horizontal Cleanout Door Rockshaft Adjustment 4-13

Auger System

 Vertical Auger 4-15

 Vertical Auger Folding Linkage Adjustment 4-16

 Vertical Auger Timing 4-17

 Horizontal Auger 4-18

5-Pin Driver Replacement 4-19

Belt Tightener Adjustment 4-24

V-Belt Alignment 4-26

 Split Tapered Bushings 4-26

Verify Telescoping PTO Shaft Length 4-27

PTO Shaft & Clutch 4-29

PTO Quick Disconnect 4-31

Tarp Troubleshooting Inspection & Maintenance 4-32

Electrical System Schematic 4-33

Electrical Over Hydraulic (EOH) System Schematic - 5 Function Control Grip Option 4-35

5 Function Remote Option Electrical Schematic 4-36

Optional Electric Over Hydraulic Valve Electric Schematic 5 Spool 4-37

Wheels & Tires

 Wheel Nut Torque Requirements 4-38

 Tire Pressure 4-39

 Tire Warranty 4-41

Torque Chart - Hardware Grade 5 4-42

Torque Chart - Hardware Grade 8 4-43

Hydraulic Fittings - Torque and Installation 4-44

FOR SCALE INFORMATION, PLEASE REFER TO YOUR SCALE MANUAL.

FOR TRACK INFORMATION, PLEASE REFER TO YOUR TRACK MANUAL.

FOR U-HARVEST SCALE INFORMATION, PLEASE REFER TO YOUR U-HARVEST MANUAL.

FOR ELECTRIC TARP INFORMATION, PLEASE REFER TO YOUR ELECTRIC TARP MANUAL.

FOR WATER DELIVERY SYSTEM INFORMATION, PLEASE REFER TO YOUR WATER DELIVERY SYSTEM MANUAL.

Table of Contents

**Section V
Parts**

Decals.....	5-2
Hitch & Tongue Components.....	5-4
Ladder Components.....	5-6
Touch-Up Paint.....	5-7
Axle & Hub Components - Model 1196 Single Wheels.....	5-8
Axle & Hub Components - Model 1396 Single Wheels.....	5-10
Hopper Components.....	5-12
Walking Tandem Assembly Components.....	5-14
Walking Tandem Mounting Components.....	5-16
Wheels & Tires.....	5-17
Dual Wheels & Tires.....	5-17
Track Axle Components - Model 1196 & 1396 w/36x148, 42x131, 42x148, & 50x148.....	5-18
Track Axle Components - Models 1196 w/36x112 & 36x131.....	5-20
Track Panel Kit Components.....	5-21
Sideboards - Model 1196.....	5-22
Sideboards - Model 1396.....	5-23
Horizontal Auger Components.....	5-24
Vertical Auger Flighting Components.....	5-26
Lower Auger Door & Cover Components.....	5-28
Lower Auger Linkage Components.....	5-30
Idler Assembly Components.....	5-32
Auger Tube Components.....	5-34
Auger Grease Bank Components.....	5-38
EOH Valve Functions & Wire Locations 5 Spool (Optional).....	5-39
EOH Valve Assembly Components 5 Spool (Optional).....	5-40
EOH Tractor Circuit Hydraulic Components (Optional).....	5-42
Optional Spout Rotate and Tilt Hydraulic Components.....	5-44
Auger Pivot Hydraulic Components.....	5-46
Auger Fold Hydraulic Components - 5 Function Hydraulic Block.....	5-47
Flow Door Circuit Hydraulic Components - 5 Function Hydraulic Block.....	5-48
Cylinders.....	5-49
Hopper Flow Door Components.....	5-50
Downspout Components.....	5-52
Switch Assembly Components (Optional).....	5-54
Rotating Spout Components.....	5-56
Cut Out Clutch PTO Assembly.....	5-58
Cut Out Clutch Components.....	5-59
Gearbox Components.....	5-60
Indicator Assembly.....	5-62

Table of Contents

Hopper Rear Electrical Components.....	5-64
Electrical Components - 5 Function Control Grip.....	5-66
Weather Guard Tarp	5-68
Hydraulic Jack - Kit #294142B (Optional).....	5-70
Video System (Optional)	5-71

FOR SCALE INFORMATION, PLEASE REFER TO YOUR SCALE MANUAL.

FOR TRACK INFORMATION, PLEASE REFER TO YOUR TRACK MANUAL.

FOR U-HARVEST SCALE INFORMATION, PLEASE REFER TO YOUR U-HARVEST MANUAL.

FOR ELECTRIC TARP INFORMATION, PLEASE REFER TO YOUR ELECTRIC TARP MANUAL.

FOR WATER DELIVERY SYSTEM INFORMATION, PLEASE REFER TO YOUR WATER DELIVERY
SYSTEM MANUAL.

Section I Safety

General Hazard Information	1-2
Safety Decals	1-3
Following Safety Instructions	1-5
Before Servicing.....	1-5
Before Operating.....	1-6
During Operation.....	1-6
Before Transporting	1-6
During Transport.....	1-7
Driveline Safety.....	1-8
Pressurized Oil	1-9
Preparing for Emergencies.....	1-10
Wearing Protective Equipment.....	1-10

General Hazard Information

No accident-prevention program can be successful without the wholehearted cooperation of the person who is directly responsible for the operation of the equipment.

A large number of accidents can be prevented only by the operator anticipating the result before the accident is caused and doing something about it. No power-driven equipment, whether it be transportation or processing, whether it be on the highway, in the field, or in the industrial plant, can be safer than the person who is at the controls. If accidents are to be prevented--and they can be prevented--it will be done by the operators who accept the full measure of their responsibility.

It is true that the designer, the manufacturer, and the safety engineer can help; and they will help, but their combined efforts can be wiped out by a single careless act of the operator.

It is said that, "the best kind of a safety device is a careful operator." We, at Unverferth Mfg. Co., Inc. ask that you be that kind of operator.



**REMEMBER:
THINK SAFETY**
A CAREFUL OPERATOR IS THE
BEST INSURANCE AGAINST AN
ACCIDENT!

SIGNAL WORDS



INDICATES AN EXTREMELY HAZARDOUS SITUATION OR ACTION THAT WILL RESULT IN SERIOUS INJURY OR DEATH.



INDICATES A HAZARDOUS SITUATION OR ACTION THAT COULD RESULT IN SERIOUS INJURY OR DEATH.



INDICATES AN UNSAFE SITUATION OR ACTION THAT MAY RESULT IN PERSONAL INJURY.



Is used for instruction on operating, adjusting, or servicing a machine.

Safety Decals

⚠ WARNING

- REPLACE LOST, DAMAGED, PAINTED, OR UNREADABLE DECALS IMMEDIATELY. IF PARTS THAT HAVE DECALS ARE REPLACED, ALSO MAKE SURE TO INSTALL NEW DECALS. THESE DECALS INFORM AND REMIND THE OPERATOR WITH OPERATIONAL INFORMATION AND SAFETY MESSAGES.

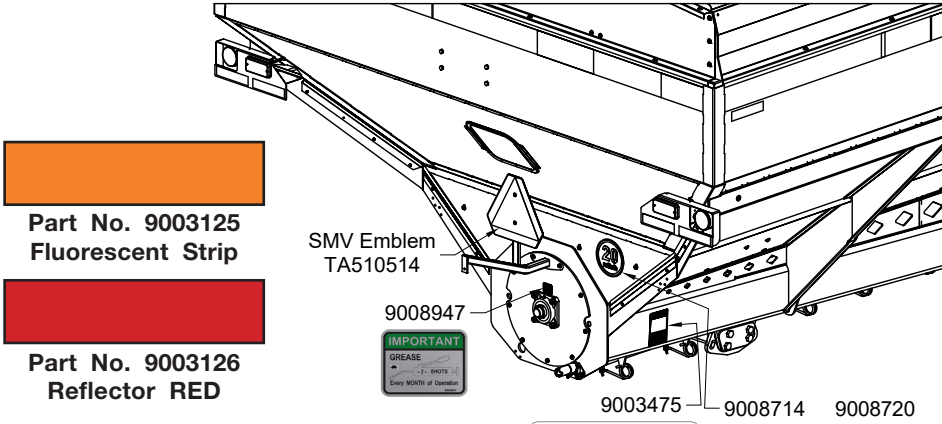
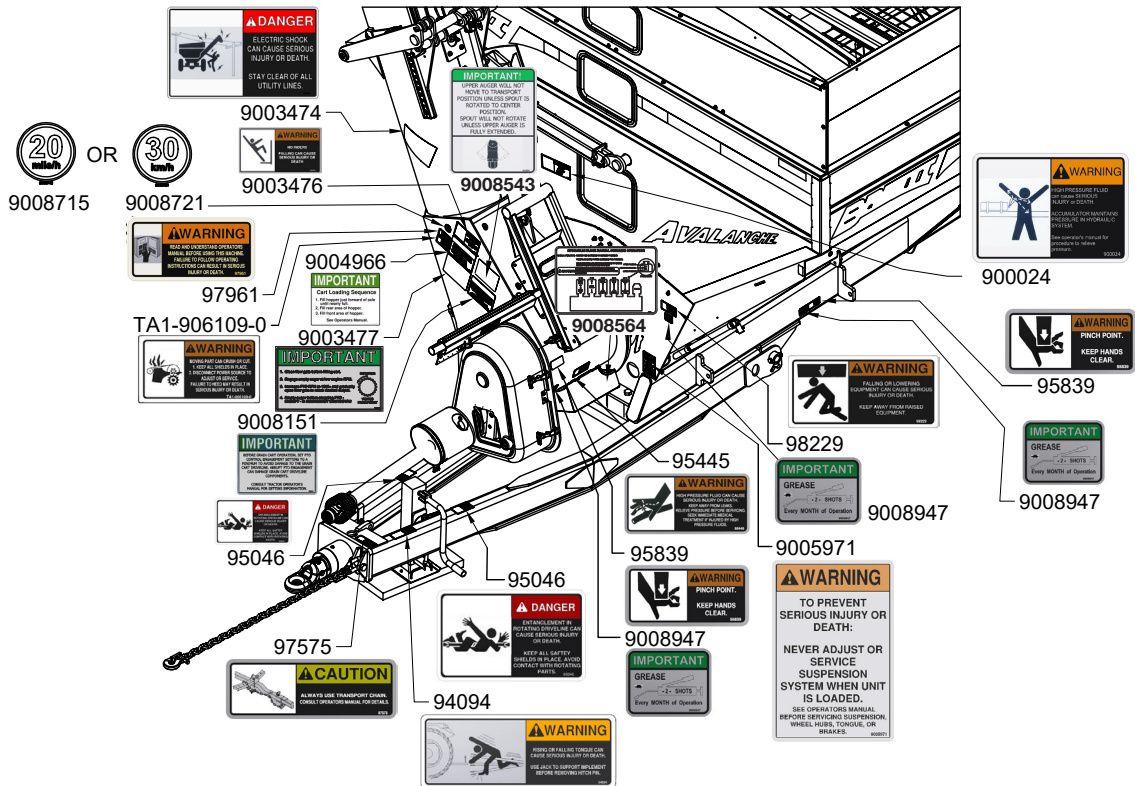

Part No. 9003125
Fluorescent Strip

Part No. 9003126
Reflector RED

94754
UM
Wheel Products
Always consult your operator's manual for correct tire pressure and wheel hardware torque specifications.

⚠ DANGER
ROTATING OR MOVING PARTS WILL CAUSE SERIOUS INJURY OR DEATH. SHUT OFF ENGINE AND DISCONNECT PTO/HYDRAULICS BEFORE SERVICING MACHINE, ENTERING GRAIN TANK, OR OPENING CLEAN-OUT DOORS.

20 OR 30 mph

Safety Decals (continued)

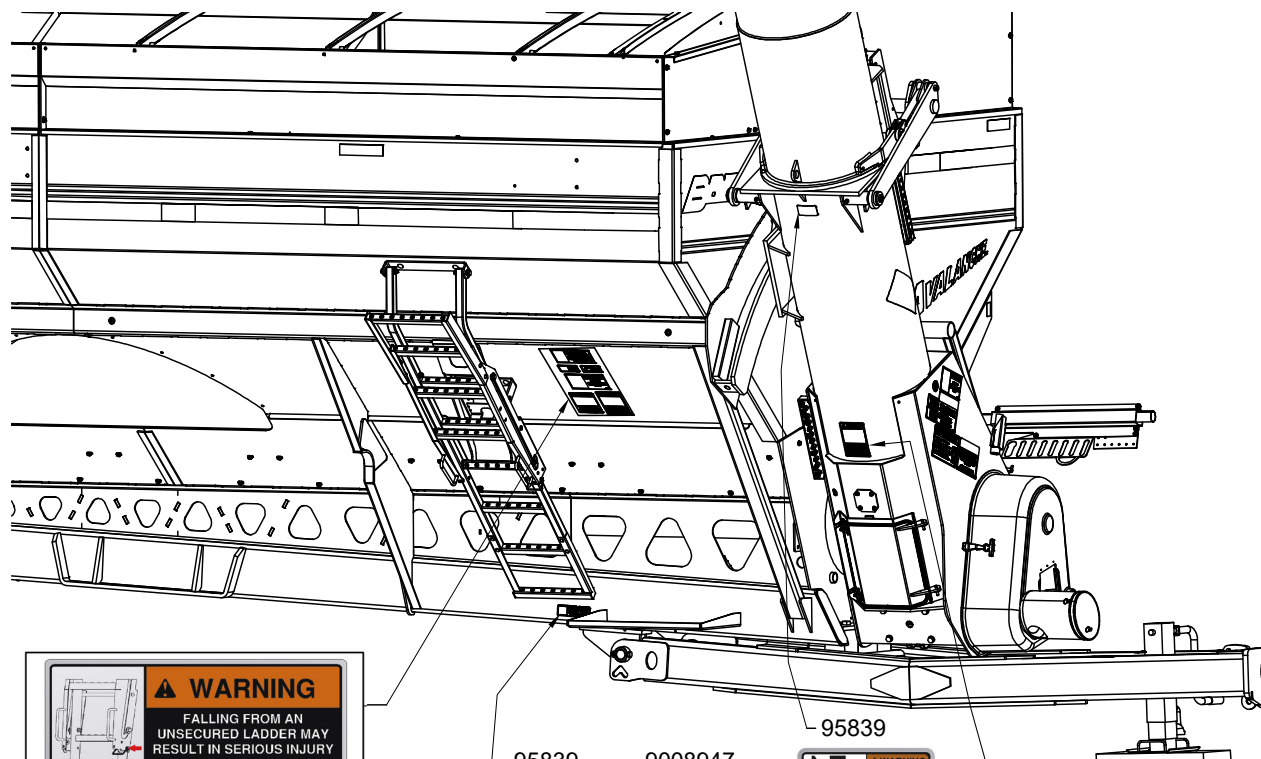

9009168

95839

95008

9003476

9003478

9003475

95839

9008947





95839

9003475



Part No. 9003127
Reflector AMBER



Following Safety Instructions

- Read and understand this operator's manual before operating. 
- All machinery should be operated only by trained and authorized personnel.
- To prevent machine damage, use only attachments and service parts approved by the manufacturer.
- Always shut towing vehicle engine and hydraulic power unit engine off & remove key before servicing the implement. 
- Avoid personal attire such as loose fitting clothing, shoestrings, drawstrings, pants cuffs, long hair, etc., that may become entangled in moving parts.
- Do not allow anyone to ride on the implement. Make sure everyone is clear before operating machine. 
- Never attempt to operate implement unless you are in the driver's seat.
- Never enter a cart containing grain. Flowing grain traps and suffocates victims in seconds. 

Before Servicing

- Avoid working under an implement; however, if it becomes absolutely unavoidable, make sure the implement is safely blocked. 
- Ensure that all applicable safety decals are installed and legible.
- When working around the implement, be careful not to be cut by sharp edges.
- To prevent personal injury or death, always ensure that there are people who remain outside the cart to assist the person working inside, and that all safe workplace practices are followed. There are restricted mobility and limited exit paths when working inside the implement.
- Secure drawbar pin with safety lock and lock tractor drawbar in fixed position.
- Explosive separation of a tire and rim can cause serious injury or death. Only properly trained personnel should attempt to service a tire and wheel assembly.

Before Operating

- Do not stand between towing vehicle and implement during hitching. 
- Always make certain everyone and everything is clear of the machine before beginning operation.
- Verify that all safety shields are in place and properly secured. 
- Ensure that all applicable safety decals are installed and legible.
- When working around the implement, be careful not to be cut by sharp edges.
- Secure drawbar pin with safety latch and lock tractor drawbar in fixed position.
- Add sufficient ballast to tractor to maintain steering and braking control at all times. Do not exceed tractor's lift capacity or ballast capacity.

During Operation

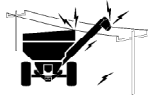
- Regulate speed to field conditions. Maintain complete control at all times.
- Never service or lubricate equipment when in operation.
- Always fold the auger to the field or transport position after unloading.
- Keep away from overhead power lines. Electrical shock can cause serious injury or death. 
- Use extreme care when operating close to ditches, fences, or on hillsides.
- Do not leave towing vehicle unattended with engine running.

Before Transporting

- Secure transport chain to towing vehicle before transporting. **DO NOT** transport without chain.
- Check for proper function of all available transport lights. Make sure that all reflectors are clean and in place on machine. Make sure the SMV emblem and SIS decals are visible to approaching traffic.
- This implement is not equipped with brakes. Ensure that the towing vehicle has adequate weight and braking capacity to tow this implement.

During Transport

- Comply with all laws governing highway safety when moving machinery.
- Use transport lights as required by all laws to adequately warn operators of other vehicles.
- Regulate speed to road conditions and maintain complete control.
- Maximum transport speed of this implement should never exceed 20 m.p.h. as indicated on the machine. Maximum transport speed of any combination of implements must not exceed the lowest specified speed of the implements in combination. Do not exceed 10 m.p.h. during off-highway travel.
- Slow down before making sharp turns to avoid tipping. Drive slowly over rough ground and side slopes.
- Do not transport grain cart on roads while loaded.
- It is probable that this implement is taller, wider and longer than the towing vehicle. Become aware of and avoid all obstacles and hazards in the travel path of the equipment, such as power lines, ditches, etc.

Driveline Safety

- Do not allow children near equipment that is running or engaged.
- Do not exceed 1000 r.p.m. PTO speed.
- Disengage the PTO, stop the tractor engine, and remove key from ignition before making inspections, or performing maintenance and repairs.
- Inspect the driveline, quick disconnect, overload shear-bolt limiter or clutch, and shielding often. Repair immediately. Use replacement parts and attaching hardware equivalent to the original equipment. Only alterations described in this manual for overall length adjustment are allowed. Any other alteration is prohibited.
- Avoid excessively long hardware or exposed and protruding parts which can snag and cause entanglement.
- Lubricate the driveline as recommended in the MAINTENANCE section.
- Keep hoses, wiring, ropes, etc. from dangling too close to the driveline.
- Install driveline and shields according to recommended lengths and attaching methods with recommended hardware. The driveline shield should rotate independently a full rotation and telescope freely. The retaining chain must be secured to the implement safety shield.
- Adjust drawbar to height and length recommended in the OPERATION section.
- Use caution when turning to avoid contact between tractor tires and driveline.
- Check the length of the telescoping members to insure the driveline will not bottom out or separate when turning and/or going over rough terrain.
- Proper extended and collapsed lengths of the telescoping PTO shaft must be verified before first operation with each and every tractor. If the extended length of the PTO shaft is insufficient, it may become uncoupled during operation and cause serious injury or death from contact with uncontrolled flailing of PTO shaft assembly components.



Pressurized Oil

- Relieve the hydraulic system of all pressure before adjusting or servicing. See hydraulic power unit manual for procedure to relieve pressure.

- High-pressure fluids can penetrate the skin and cause serious injury or death. Use cardboard or wood to detect leaks in the hydraulic system. Seek medical treatment immediately if injured by high-pressure fluids.

- Accumulators used in this hydraulic system can retain fluid under pressure even after tractor hydraulic valve is placed in FLOAT. See tractor operators manual for procedure to relieve pressure.

- Hydraulic system must be purged of air before operating to prevent serious injury or death.

- Do not bend or strike high-pressure lines. Do not install bent or damaged tubes or hoses.

- Repair all oil leaks. Leaks can cause fires, personal injury, and environmental damage.

- Route hoses and lines carefully to prevent premature failure due to kinking and rubbing against other parts. Make sure that all clamps, guards and shields are installed correctly.

- Check hydraulic hoses and tubes carefully. Replace components as necessary if any of the following conditions are found:
 - End fittings damaged, displaced, or leaking.
 - Outer covering chafed/cut or wire reinforcing exposed.
 - Outer covering ballooning locally.
 - Evidence of kinking or crushing of the flexible part of a hose.

Preparing for Emergencies

- Keep a first aid kit and properly rated fire extinguisher nearby.



- Keep emergency numbers for fire, rescue, and poison control personnel near the phone.



Wearing Protective Equipment

- Wear clothing and personal protective equipment appropriate for the job.



- Wear steel-toed shoes when operating.



- Wear hearing protection when exposed to loud noises.



- Do not wear additional hearing impairing devices such as radio headphones, etc.



Section II Set Up

Set Up Checklist.....	2-2
Basic Cart Set Up	
Hydraulic System.....	2-3
Wheel/Tire Set Up.....	2-3
Auger Spout Cylinder Stop Removal.....	2-4
PTO Brackets Removal.....	2-4
Jack.....	2-5
Optional Hydraulic Jack.....	2-5
Driveline Set Up.....	2-7
Coupling The Cut-Out Clutch.....	2-7
SMV Emblem and SIS Decal.....	2-8
Video System (Optional).....	2-8
Upper Ladder Extension to Operating Position.....	2-9
Horizontal Cleanout Door Inspection.....	2-10
Belt Engagement.....	2-12
Operational Check.....	2-13

FOR SCALE INFORMATION, PLEASE REFER TO YOUR SCALE MANUAL.

FOR TRACK INFORMATION, PLEASE REFER TO YOUR TRACK MANUAL.

FOR U-HARVEST SCALE INFORMATION, PLEASE REFER TO YOUR U-HARVEST MANUAL.

FOR ELECTRIC TARP INFORMATION, PLEASE REFER TO YOUR ELECTRIC TARP MANUAL.

FOR WATER DELIVERY SYSTEM INFORMATION, PLEASE REFER TO YOUR WATER DELIVERY SYSTEM MANUAL.

Set Up Checklist

After the cart has been completely assembled, use the following checklist and inspect the cart. Check off each item as it is found satisfactory or after proper adjustment is made.

- Set or Calibrate tractor PTO control engagement to MINIMUM setting. Refer to tractor operator's manual for setting information.
- Remove auger spout cylinder stop.
- Remove PTO brackets.
- Torque wheel nuts and check tire pressure as specified in MAINTENANCE section.
- Verify track has been aligned and is properly conditioned. (If applicable)
- Inflate tires to specified air pressure. (if applicable)
- Lubricate all grease fittings and check gearbox oil level.
- Inspect cleanout door assembly for play or movement, refer to "Vertical & Horizontal Clean-Out Door Operation" in the OPERATION section.
- Verify all safety decals are correctly located and legible. Replace if damaged.
- Verify all reflective decals are correctly located.
- Check SMV decal and SIS decals are in place, clean and visible.
- Verify transport lights are working properly.
- Verify PTO length, see "Verify Telescoping PTO Shaft Length" in MAINTENANCE section.
- Align and properly tension belts/chains. See "Belt Tightener Adjustment" and "V-Belt Alignment" in MAINTENANCE section.
- Ensure safety screens over horizontal auger are in place and properly secured.
- Install transport chain and torque hardware to specification. See "Transport Chain Connection" in OPERATION section.
- Paint all parts scratched in shipment.
- Test run the augers. See "Auger Operation" in OPERATION section.

Basic Set Up

Due to shipping requirements and various dealer-installed options, some initial cart set up will be required after it arrives from the factory. Use the following procedures as needed for initial cart set up.



Hydraulic System

Check all hoses and cylinders for signs of leakage. Hoses should not be kinked, twisted or rubbing against sharp edges. Re-route or repair hoses as necessary. Refer to SAFETY section for additional information on safe repair and inspection of hydraulic components.

Wheel/Tire Set Up

Tire Pressure

Tire pressure must be verified before first use and adjusted as necessary. Refer to MAINTENANCE section of this manual for information on tire pressure.

Wheel Nuts

CAUTION

- **IMPROPERLY TORQUED WHEEL NUTS/BOLTS CAN CAUSE A LOSS OF IMPLEMENT CONTROL AND MACHINE DAMAGE. WHEEL NUTS/BOLTS MUST BE CHECKED REGULARLY. SEE TORQUE PAGE IN THE MAINTENANCE SECTION FOR PROPER WHEEL NUT/BOLT SPECIFICATIONS. WARRANTY DOES NOT COVER FAILURES CAUSED BY IMPROPERLY TORQUED WHEEL NUTS/BOLTS.**

IMPORTANT

- *Installing wheels without the proper inset/offset could result in hub or spindle failure. This will cause substantial damage to cart and is not covered by warranty. Inset/offset will vary depending on tire size. Consult dealer for proper inset/offset.*

Wheel nuts must be torqued to specification. Refer to MAINTENANCE section for proper wheel nut torque.

The wheel dish will put the tires to the narrowest or widest position.

Basic Set Up (continued)

Auger Spout Cylinder Stop Removal

Remove the shipping stop from the spout tilt cylinder. (Figs. 2-1 and 2-2)

IMPORTANT

- *Cylinder stop must be removed before operating the auger spout. Failure to remove stop will result in damage to the cylinder and spout.*

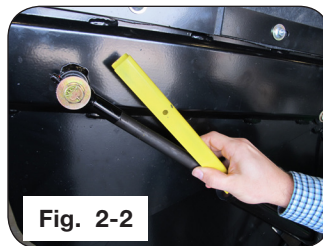
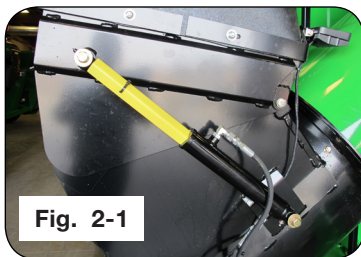

PTO Brackets Removal

Remove the PTO assembly and PTO brackets on the tongue before operating the auger pivot or when connecting the driveline assembly to the tractor. (Figs. 2-3 and 2-4) Keep PTO brackets for seasonal storage. Refer to “Seasonal Storage” in MAINTENANCE section.

IMPORTANT

- *PTO assembly and PTO brackets must be removed before operating the auger before or when connecting the driveline assembly to the tractor. Failure to remove PTO assembly and PTO brackets will result in damage to the PTO assembly, tongue, auger, and tractor.*

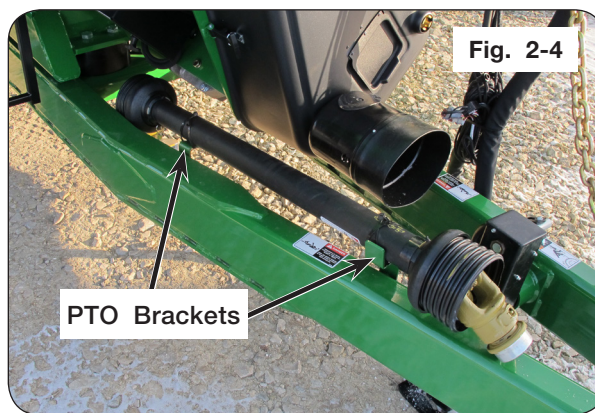
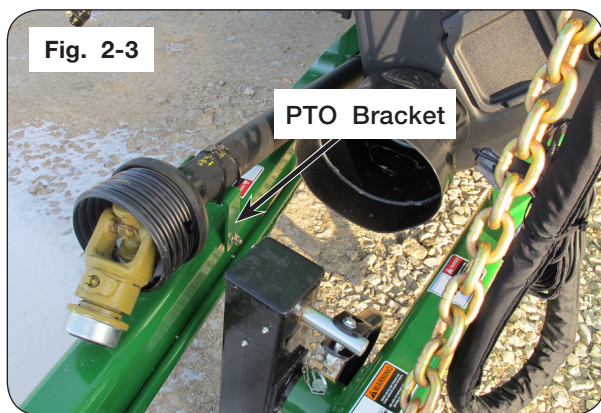

Basic Set Up (continued)

Jack

WARNING

- **UNHITCHING A LOADED CART CAN CAUSE SERIOUS INJURY OR DEATH DUE TO TONGUE RISING OR FALLING. ALWAYS HAVE A LOADED CART ATTACHED TO A TRACTOR. THE JACK IS INTENDED TO SUPPORT AN EMPTY CART ONLY.**

Attach jack to left-inside frame using pin and hair pin. (Fig. 2-5) Pivot the jack 90 degrees and reinstall pin for field use.

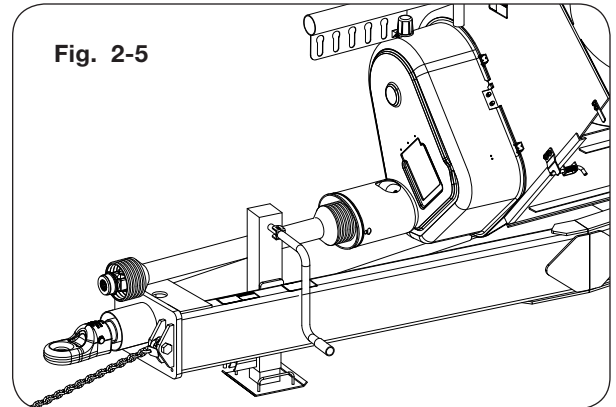

Optional Hydraulic Jack

1. Assemble hoses (9006068) and fittings to cylinder (9009047) as shown in figure 2-6. The valve needs to be attached to the hose on the butt end of the cylinder. Assemble the fittings on the cylinder so they face each other, then store the hydraulic hoses on the hose caddy.

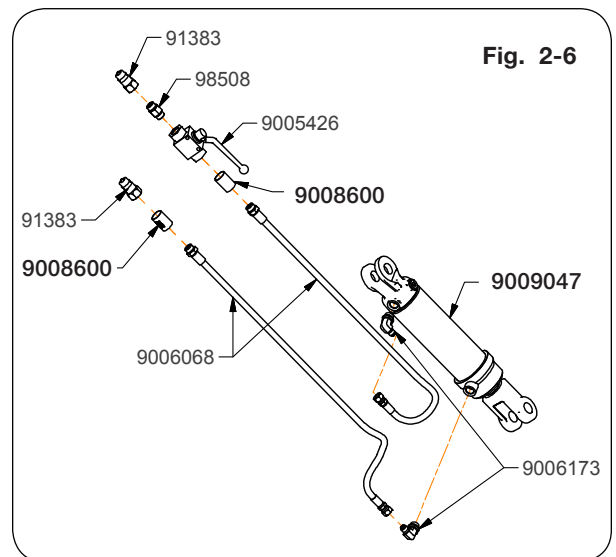

Basic Set Up (continued)

Optional Hydraulic Jack

2. Assemble the cylinder (9009047) and jack foot (271723B) to the jack weldment (271712B) as shown in figure 2-7 using 1"-8UNC x 7" capscrews (9390-197) and 1"-8UNC locknuts (92199).

NOTE: Ensure all jack leg weldment (271712B) joints can pivot freely, especially jack foot (271723B).

3. Tighten 1" hardware to jack leg weldment and allow the cylinder and jack foot to freely pivot. (Fig. 2-7)

4. Attach the jack weldment (271712B) to the lower tabs behind the hitch plate on the tongue, shown in figure 2-8 using 1"-8UNC x 7" capscrews (9390-197) and 1"-8UNC locknuts (92199).

5. Tighten 1" hardware to jack leg weldment and allow the joint to pivot. (Fig. 2-8)

6. Align the base end of the cylinder with the lug on the top of the tongue and assemble the cylinder pin (272587) and snap rings (91192) shown in figure 2-9.

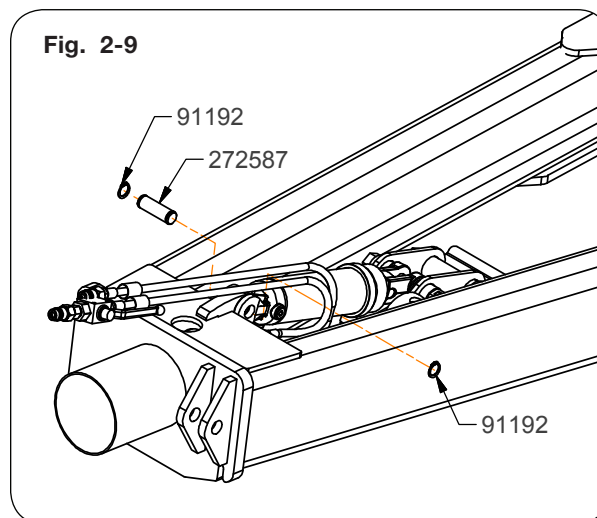
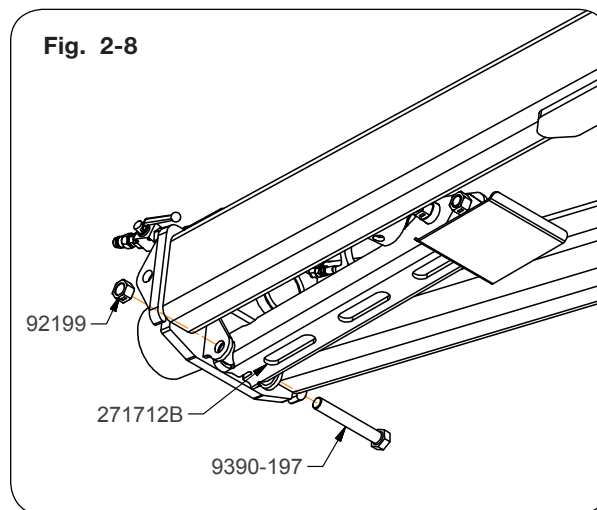
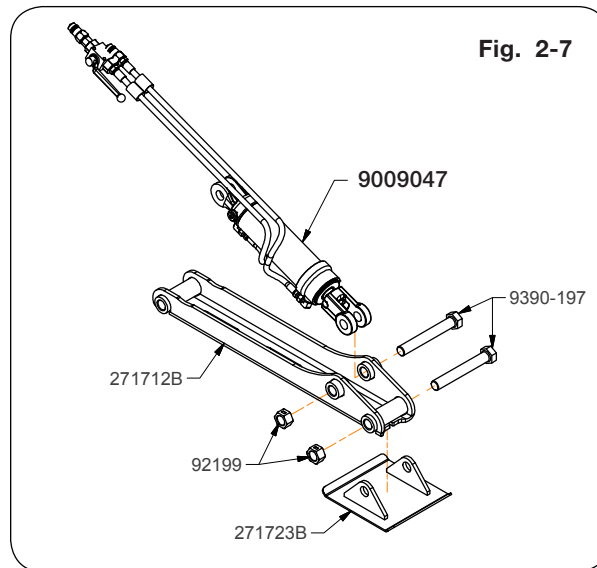

Basic Set Up (continued)

Driveline Set Up

Clean and grease the Implement Gearbox splined shaft. Gearbox shaft guard has access doors for installing and removing of driveline.

DANGER

- **ENTANGLEMENT WITH THE DRIVELINE WILL CAUSE SERIOUS INJURY OR DEATH. KEEP ALL GUARDS AND SHIELDS IN GOOD CONDITION AND PROPERLY INSTALLED AT ALL TIMES. AVOID PERSONAL ATTIRE SUCH AS LOOSE FITTING CLOTHING, SHOE STRINGS, DRAWSTRINGS, PANTS CUFFS, LONG HAIR, ETC. THAT CAN BECOME EN-TANGLED IN A ROTATING DRIVELINE.**

Coupling The Cut-Out Clutch

Engage PTO drive shaft onto implement PTO shaft until retaining groove of implement PTO shaft aligns with clamping cone hole. Insert clamping cone into threaded hole, hand tighten. Torque cone to 75 ft.-lb. (Fig. 2-10)

NOTE: See MAINTENANCE section - PTO Quick Disconnect - for disassembly instructions.

NOTE: See MAINTENANCE section - Verify PTO length.

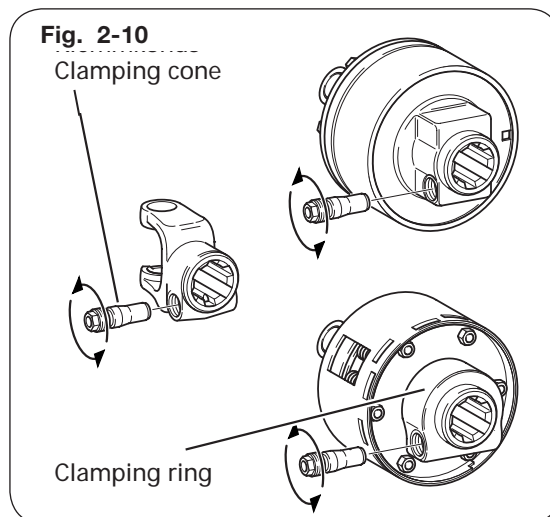

Basic Set Up (continued)

SMV Emblem & SIS Decal

The reflective surface of the SMV must face rearward. This may require removal of film protecting the reflective surface or removing and reinstallation of the SMV. (Fig. 2-11)

When reinstalling the SMV make sure that it is mounted with the wide part of the SMV at the bottom.

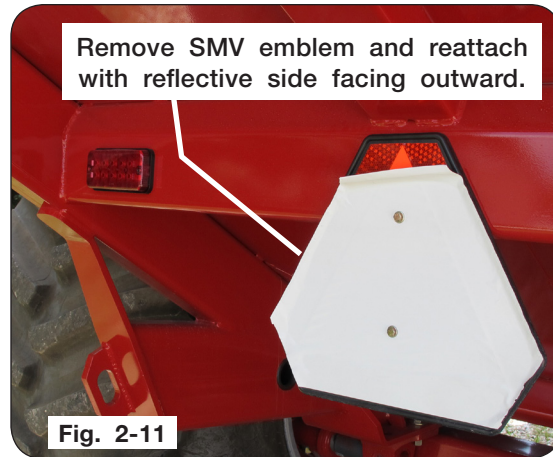

Ensure the SIS decals (one on the front and one on the rear of the cart) are clean and visible. (Fig. 2-12)

For front and rear 20 M.P.H. SIS decals, order 9008715 & 9008714.

For front and rear 30 K.P.H. SIS decals, order 9008721 & 9008720.



Video System (Optional)

The video system includes its own installation instruction sheet. Reference the provided instruction sheet.

Basic Cart Set Up (continued)

Upper Ladder Extension to Operating Position

⚠ WARNING

- FALLING OR LOWERING EQUIPMENT CAN CAUSE SERIOUS INJURY OR DEATH. KEEP EVERYONE AWAY FROM EQUIPMENT WHEN SUSPENDED, RAISING, OR LOWERING.
- KEEP HANDS CLEAR OF PINCH POINT AREAS.
- DO NOT ALLOW ANYONE TO RIDE ON THE LADDER. MAKE SURE EVERYONE IS CLEAR BEFORE OPERATING MACHINE OR TOWING VEHICLE.
- TO PREVENT PERSONAL INJURY OR DEATH, ALWAYS ENSURE THAT THERE ARE PEOPLE WHO REMAIN OUTSIDE THE CART TO ASSIST THE PERSON WORKING INSIDE, AND THAT ALL SAFE WORKPLACE PRACTICES ARE FOLLOWED. THERE ARE RESTRICTED MOBILITY AND LIMITED EXIT PATHS WHEN WORKING INSIDE THE IMPLEMENT.
- NEVER ENTER A CART CONTAINING GRAIN. FLOWING GRAIN TRAPS AND SUFFOCATES VICTIMS IN SECONDS.

NOTE: Ensure ladder and steps are free from snow/debris before changing ladder positions and climbing.

NOTE: To change ladder assembly positions, refer to “Ladder Operation” in the OPERATION section.

1. Move the upper ladder extension (289707B) from shipping position by removing the 5/16”-18UNC x 3/4” carriage bolts (9388-024), 1/4” flat washers (9405-064) and 5/16”-18UNC lock nuts (9008441). Keep hardware for next step. (Fig. 2-13)
2. Using hardware from step 1, attach upper ladder extension to the higher set of holes to be in operating position. (Fig. 2-13, Fig. 2-14 and 2-15)
3. Torque hardware to 17 ft.-lbs.

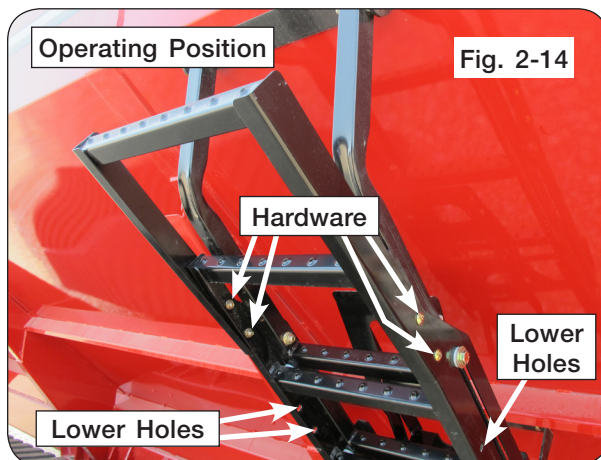
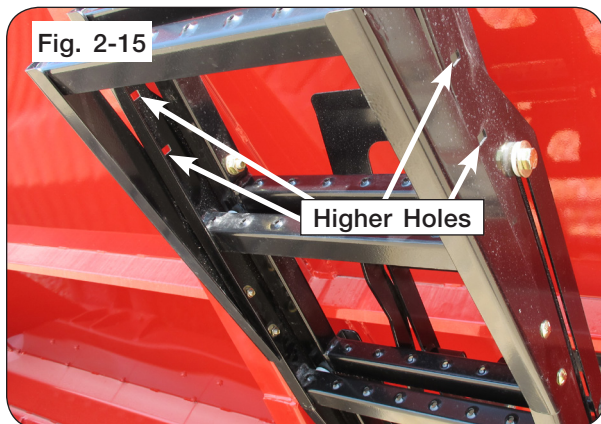
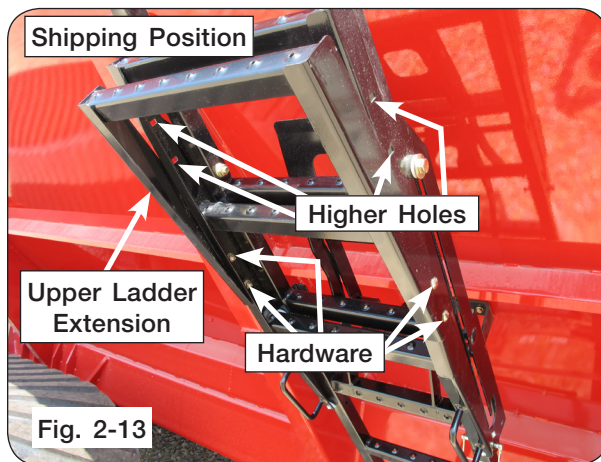

Basic Cart Set Up (continued)

Horizontal Cleanout Door Inspection

⚠ WARNING

- MOVING OR ROTATING COMPONENTS CAN CAUSE SERIOUS INJURY OR DEATH. ENSURE SERVICE COVERS, CHAIN/BELT COVERS AND CLEANOUT DOORS ARE IN PLACE AND SECURELY FASTENED BEFORE OPERATING UNIT.
- KEEP HANDS CLEAR OF PINCH POINT AREAS.
- TIPPING OR MOVEMENT OF THE MACHINE CAN CAUSE SERIOUS INJURY OR DEATH. BE SURE THE MACHINE IS SECURELY BLOCKED.
- EYE PROTECTION AND OTHER APPROPRIATE PERSONAL PROTECTIVE EQUIPMENT MUST BE WORN WHILE SERVICING THE IMPLEMENT.

NOTE: For cleanout door assembly operation, refer to “Vertical & Horizontal Cleanout Door Operation” in the OPERATION section.

NOTE: This procedure is a two-person process. One person operates the tensioner handle while the second person inspects the horizontal cleanout doors.

1. Park the unit on a firm, level surface. Block the wheels/tracks on the machine to keep the unit from moving. Set the vehicle parking brake, shut off the engine and remove the ignition key.



2. Use the tensioner handle, located on the left-hand side of the grain cart, behind the first panel to open and close the horizontal cleanout doors.
3. Insert tensioner handle into cleanout door receiver coupler on the rear panel, and remove lynch pin from rockshaft. Keep lynch pin. (Fig. 2-16)
4. Rotate tensioner handle clockwise to open the doors. (Fig. 2-17 and 2-18)
5. Clean the door area of debris that may prevent the door from shutting completely. (Fig. 2-17 & 2-18)
6. Inspect the cleanout door and rockshaft for loose hardware. Tighten loose hardware, but do not torque fasteners so the doors cannot freely pivot. (Fig. 2-17 & 2-18)

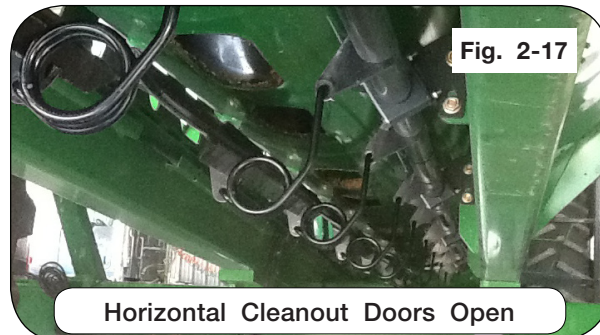
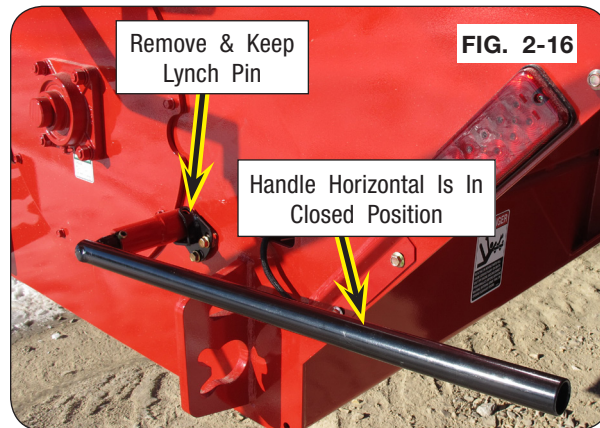

Basic Cart Set Up (continued)

Horizontal Cleanout Door Inspection

7. If plate insert needs adjustment, loosen the two flat head machine screws holding the plate in position. (Fig. 2-19)
8. Ensure the plate inserts are aligned and fit into the belly pan cut-outs. (Fig. 2-19)

NOTE: As the tensioner handle is rotated counter-clockwise near the end of the close position, the coiled springs will extend to apply pressure to cleanout doors. If the doors do not close or visible door perimeter gaps are present, adjust the rockshaft. See “Horizontal Cleanout Door Rockshaft Adjustment” in the MAINTENANCE section.

9. Close the cleanout doors. Re-insert lynch pin into rockshaft and store handle.

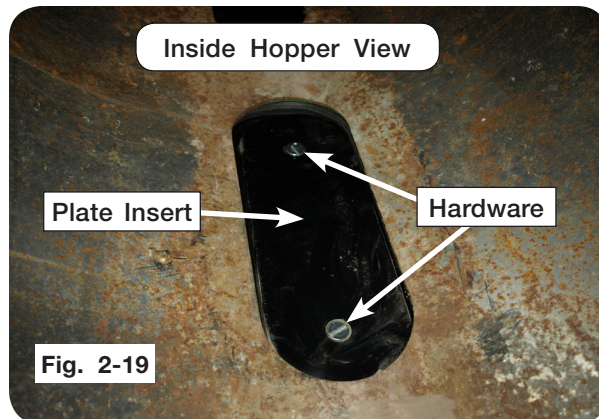

Basic Set Up (continued)

Belt Engagement

WARNING

- MOVING OR ROTATING COMPONENTS CAN CAUSE SERIOUS INJURY OR DEATH. ENSURE SERVICE COVERS, CHAIN/BELT COVERS AND CLEAN-OUT DOORS ARE IN PLACE AND SECURELY FASTENED BEFORE OPERATING UNIT.

The unit is shipped without the tension applied to the belts. To engage the tensioner use the belt tensioner handle, located on the left-hand side of the grain cart, behind the first panel. (Fig. 2-20 and 2-21)



Fig. 2-20

Handle down is in engaged position



Fig. 2-21

Handle up is in disengaged position

Basic Set Up (continued)

Operational Check

WARNING

- **MOVING OR ROTATING COMPONENTS CAN CAUSE SERIOUS INJURY OR DEATH. ENSURE SERVICE COVERS, CHAIN/BELT COVERS AND CLEAN-OUT DOOR ARE IN PLACE AND SECURELY FASTENED BEFORE OPERATING UNIT.**

IMPORTANT

- *Before running the auger pivot, the vertical auger clean-out door must be closed to prevent machine damage.*

Once set-up has been completed, run the cart to check for operation and functionality:

1. Lights - Work, Turn, Brake
2. Flow Door
3. Flow Door Indicator
4. Cleanout Doors Open/Close
5. Auger Fold
6. Auger Pivot
7. Spout Rotate & Pivot (if applicable)
8. Auger Startup & Shut-down

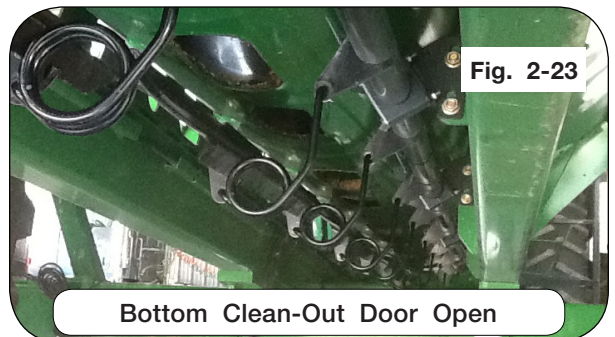
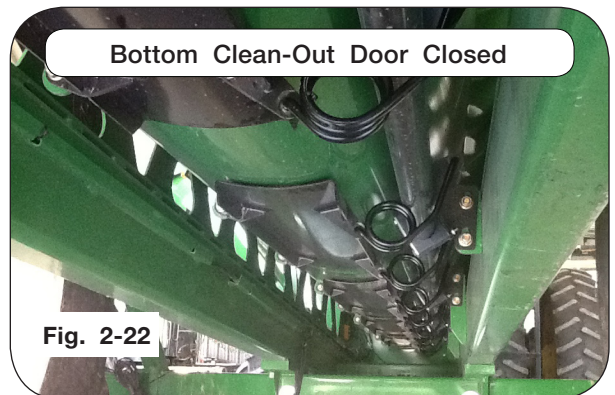

Notes

Section III Operation

Operating Checklist.....	3-2
Preparing Tractor.....	3-3
Preparing Cart.....	3-3
Lubrication.....	3-4
Video System (Optional).....	3-4
Hitching to Tractor	
Drawbar Connection	3-5
Jack Usage.....	3-6
Optional Hydraulic Jack Usage	3-7
Transport Chain Connection.....	3-8
Hydraulic Connections	3-9
Towing	3-11
Electrical Connections.....	3-12
Electric Over Hydraulic Operation (Optional)	3-13
Manual Override for Optional Electric Over Hydraulic System	3-16
Vertical & Horizontal Cleanout Door Operation	3-18
Opening Vertical Cleanout Door	3-18
Closing Vertical Cleanout Door.....	3-19
Horizontal Cleanout Door.....	3-20
Auger Operation	
PTO-Driven Auger	3-22
Auger Overload Procedure.....	3-24
Vertical Auger Fold.....	3-25
Auger Field Rest Position.....	3-26
Auger Transport Position	3-27
Upper Auger Rest Adjustments	3-28
Troubleshooting.....	3-29
Auger Switch Troubleshooting.....	3-31
Ladder Operation.....	3-32
Weather Guard Tarp.....	3-36

FOR SCALE INFORMATION, PLEASE REFER TO YOUR SCALE MANUAL.

FOR TRACK INFORMATION, PLEASE REFER TO YOUR TRACK MANUAL.

FOR U-HARVEST SCALE INFORMATION, PLEASE REFER TO YOUR U-HARVEST MANUAL.

FOR WATER DELIVERY SYSTEM INFORMATION, PLEASE REFER TO YOUR WATER DELIVERY SYSTEM MANUAL.

Operating Checklist

- Read and understand all safety precautions before operating cart.
- R.V. antifreeze needs to be completely flushed from the Water Delivery System and disposed of properly. Make certain the Water Delivery System only contains water before placing the Water Delivery System in service. (If applicable)
- Set or Calibrate tractor PTO control engagement to MINIMUM setting. Refer to tractor operator's manual for setting information.
- Torque wheel nuts and check tire pressure as specified in MAINTENANCE section.
- Verify track has been aligned and is properly conditioned. (If applicable)
- Inflate tires to specified air pressure. (if applicable)
- Lubricate all grease fittings and check gearbox oil level.
- Test operation and functionality of flow door indicator, auger fold, auger pivot, spout rotate, and spout tilt.
- Verify all reflective decals are correctly located.
- Check SMV sign and SIS decals are clearly visible with the cart attached to the tractor.
- Verify transport lights are working properly. Check and follow all regulations before towing on a road or highway.
- Verify hitch height and length as outlined in OPERATION section.
- Verify PTO length, see “Verify Telescoping PTO Shaft Length” in MAINTENANCE section.
- Align and properly tension belts. See “Belt Tightener Adjustment” and “V-Belt Alignment” in MAINTENANCE section.
- Ensure safety screens over horizontal auger are in place and properly secured.
- Install transport chain and torque hardware to specification. See “Transport Chain Connection” in OPERATION section.
- Test run the augers. See “Auger Operation” in OPERATION section.

Preparing Tractor

Before operating cart, read the tractor Operator's Manual and gain an understanding of its safe methods of operation.

Check the tractor brakes and transport lights. Make sure they are in proper working order.

Check if the tractor has multiple PTO engagement modulation settings and has the latest PTO engagement software from the OEM. If unsure, contact your local dealer for tractor capabilities and recommended setting for grain cart operation.

Set or Calibrate tractor PTO control engagement modulation to MINIMUM setting. Refer to tractor operator's manual for setting information.

Check the tractor hydraulic oil reservoir and add oil if needed.

Verify that the tractor is adequately ballasted for drawbar operation at the anticipated draft load. See tractor manual for ballasting instructions.

If possible, adjust the tractor drawbar vertically so the topside of the drawbar is approximately 17-22 inches from the ground. Ensure that the drawbar is locked in the center position.

Check that the drawbar is in the required 20" position from end of PTO shaft to center of drawbar hole, and will adequately support loads.

On tractors equipped with a 3-point hitch, raise and secure the linkage to prevent interference with the cart tongue and hydraulic hoses during turning. It may be necessary to remove tractor 3-point quick attach to avoid damage during turning.

Preparing Cart

Perform the service checks as outlined below. Repair or replace any damaged or worn parts before operating.

Hardware

Check for loose bolts and nuts, and tighten as needed. Check again after the first half-day of operation.

Pivot Pins

Check that all pins are in place and in good condition. Replace any worn, damaged or missing pins.

Hitch

Check hitch wear plates for damage and wear. Be aware of the size of hitch adapter bushing that is being used. Select correct size for the hitch pin/draw bar you are using.

NOTE: The cart comes standard with a Category 4 hitch. A Category 5 tongue is available. Contact your dealer for a CAT 5 tongue if required.

Auger

Inspect auger for damage and wear.

Preparing Cart (continued)

Hydraulic System

Check all hoses and cylinders for signs of leakage. Hoses should not be kinked, twisted or rubbing against sharp edges. Re-route or repair hoses as necessary. Refer to SAFETY section for additional information on safe repair and inspection of hydraulic components.

Tires/Wheels

Check tire pressures and maintain at recommended values listed in the MAINTENANCE section of this manual.



CAUTION

- **IMPROPERLY TORQUED WHEEL NUTS/BOLTS CAN CAUSE A LOSS OF IMPLEMENT CONTROL AND MACHINE DAMAGE. WHEEL NUTS/BOLTS MUST BE CHECKED REGULARLY. SEE TORQUE PAGE IN THE MAINTENANCE SECTION FOR PROPER WHEEL NUT/BOLT SPECIFICATIONS. WARRANTY DOES NOT COVER FAILURES CAUSED BY IMPROPERLY TORQUED WHEEL NUTS/BOLTS.**

IMPORTANT

- *Installing wheels without the proper inset/outset could result in hub or spindle failure. This will cause substantial damage to cart and is not covered by warranty. Inset/outset will vary depending on tire size. Consult dealer for proper inset/offset.*

For questions regarding new tire warranty, please contact your local original equipment tire dealer. **USED TIRES CARRY NO WARRANTY.** Tire manufacturers' phone numbers and web sites are listed in the MAINTENANCE section of this manual for your convenience.

Lubrication

Lubricate the cart as outlined in the MAINTENANCE section of this manual.

Video System (Optional)

IMPORTANT

- *Do not operate video system below 15°F. Damage to video system can occur.*
- The video system (265770) includes its own operation instruction sheet.

Hitching to Tractor

Drawbar Connection

This cart is intended to be hitched to a tractor draw bar. Do not attempt to hitch to any other location on the tractor other than the drawbar.

The cart comes with a CAT 4 hitch for use with a 1 1/2" pin and designed for a clevis-type tractor drawbar. If a 1 1/2" or 1 3/4" diameter hitch pin is used, a corresponding bushing must be inserted into the hitch tang and held in place with o-rings. If a bushing is already in the hitch, use a punch and hammer to remove and replace with the correctly sized bushing. (Figure 3-1)

NOTE: Use of the proper hitch pin/bushing will prevent excessive wear and tear on both the cart and tractor.

NOTE: Bushings and o-rings are stored in the toolbox on the right-hand side of the cart.

Lock tractor drawbar in center position.

Set tractor drawbar length to 20" from the end of the tractor PTO shaft to center of hitch tang pinhole.

WARNING

- **DO NOT STAND BETWEEN THE CART AND TRACTOR WHEN HITCHING. ALWAYS ENGAGE PARKING BRAKE AND STOP ENGINE BEFORE INSERTING HITCH PIN.**

Place wear shoe (281663-CAT 3; 281898-CAT 4; 281899-CAT 5) between tractor hitch and grain cart hitch. (Figure 3-2)

After inserting drawbar pin, secure drawbar pin with a locking device to prevent uncoupling during use.

NOTE: Hitch tang can be flipped providing a drawbar connection height difference of 2 7/8" (Figure 3-3). Position the hitch tang to help assure a level cart when loaded, or the rear of the hopper slightly higher than the front, to maintain rear slope cleanout. Whenever the hitch tang is flipped, the driveline clearances need to be reviewed.

FIG. 3-1

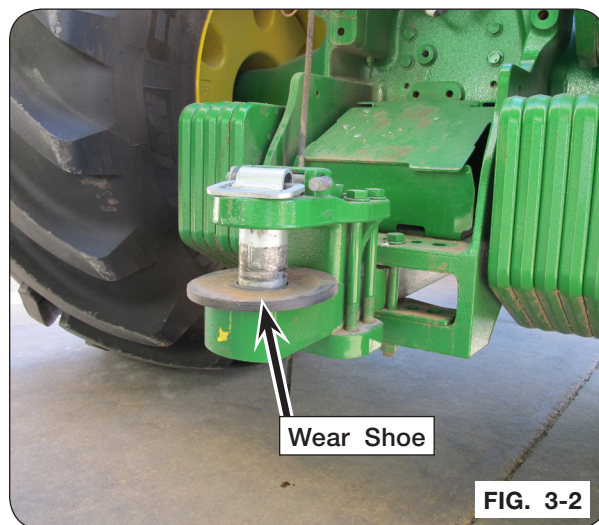
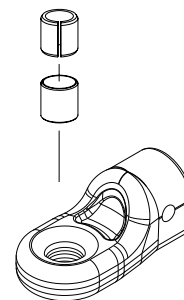

FIG. 3-2

2 7/8" Higher Than
The Standard Position

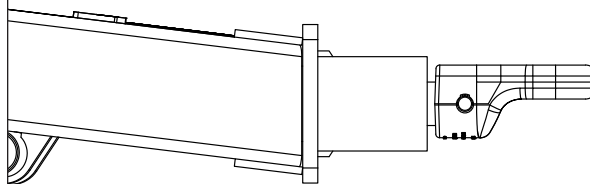

FIG. 3-3

Hitching to Tractor (continued)

WARNING

- UNHITCHING A LOADED CART CAN CAUSE SERIOUS INJURY OR DEATH DUE TO TONGUE RISING OR FALLING. ALWAYS HAVE A LOADED CART ATTACHED TO A TRACTOR. THE JACK IS INTENDED TO SUPPORT AN EMPTY CART ONLY.

Jack Usage

Use jack to support an empty grain cart, never a loaded grain cart. Always have a loaded grain cart hooked to tractor. Attach jack to left inside frame using pin and hair pin. Pivot the jack 90 degrees and reinstall pin for field use. (Fig. 3-4)

IMPORTANT

- After cart is hitched to tractor, pivot jack to storage location shown in Fig. 3-5.

Fig. 3-4

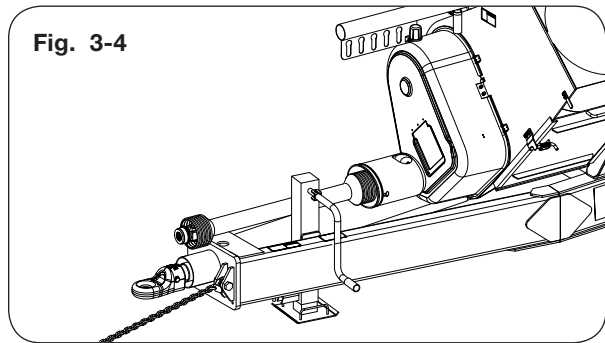

Fig. 3-5



Hitching to Tractor (continued)

Optional Hydraulic Jack Usage

⚠ WARNING

- HIGH-PRESSURE FLUIDS CAN PENETRATE THE SKIN AND CAUSE SERIOUS INJURY OR DEATH. USE CARDBOARD OR WOOD TO DETECT LEAKS IN THE HYDRAULIC SYSTEM. SEEK MEDICAL TREATMENT IMMEDIATELY IF INJURED BY HIGH-PRESSURE FLUIDS.
- TIPPING OR MOVEMENT OF THE MACHINE CAN CAUSE SERIOUS INJURY OR DEATH. BE SURE THE MACHINE IS SECURELY BLOCKED.
- OPENING OF HYDRAULIC VALVE CAN CAUSE SUDDEN MACHINE MOVEMENT. KEEP CLEAR OF MACHINE WHEN OPENING VALVE.

IMPORTANT

- After cart is hitched to tractor, retract hydraulic cylinder to store hydraulic jack between the frame rails.

Use hydraulic jack to support an empty grain cart, never a loaded grain cart. Always have a loaded grain cart hooked to tractor.

Always close the manual valve for the hydraulic jack for in-field use and when unhitched from the tractor.

1. Remove hoses from storage slots.
2. Attach jack cylinder hose couplers to tractor.
3. Open valve to allow hydraulic flow.
4. Use tractor hydraulic valve to extend cylinder and lift tongue.
5. Once attached to tractor drawbar, retract cylinder to lower tongue and to raise jack into storage position.
6. Close valve, relieve pressure on couplers (see tractor operators manual for procedure) and then disconnect hose couplers from tractor.
7. Place hose couplers into storage caddy. Be sure to route hoses to clear PTO driveline during operation.
8. Check for leaks.

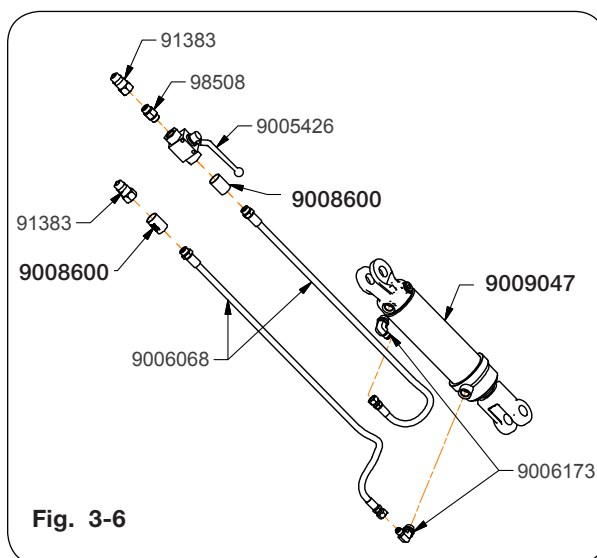

Hitching to Tractor (continued)

Transport Chain Connection



CAUTION

- ALWAYS USE TRANSPORT CHAIN WHEN TRANSPORTING IMPLEMENTS. FAILURE TO USE A TRANSPORT CHAIN COULD CAUSE PERSONAL INJURY IF CART BECOMES DISENGAGED.
- REPLACE TRANSPORT CHAIN IF ANY LINK OR END FITTING IS BROKEN, STRETCHED OR DAMAGED. DO NOT WELD TRANSPORT CHAIN.

Always use intermediate chain support when connecting the grain cart directly to a tractor. DO NOT use the intermediate chain support as the chain attaching point. Fig. 3-7 shows how the transport chain must be installed between the tractor and grain cart.

The transport chain is rated for towing the grain cart empty on public roads. Use only ASABE approved chains. Allow no more slack in the chain than necessary to permit turning.



Fig. 3-7

Hitching to Tractor (continued)

Hydraulic Connections

Clean hydraulic hose couplers before connecting to the tractor. For convenience, this unit is equipped with color hose grips attached to the hydraulic hoses. This will help in identifying the hose function and correct hook up. (FIG. 3-8)

NOTE: The half gray color hose grip is for the retract port.

Color	Function
Red	Flow Door Open / Close
Yellow	Spout Tilt In / Out
Tan	Joystick / Spout Rotate
Green	Auger Fold / Unfold
Blue	Auger Pivot Up / Down
Black	Jack Raise / Lower
Orange	Water Pump
Optional	Hydraulic Pressure / Return

After initial set-up or replacement of any hydraulic component on the cart, air must be removed from the cart's hydraulic system. Reference "Hydraulic System - Purge Hydraulic System" section in the MAINTENANCE section.

Route hoses away from areas that may cause abrasion or kinking of hoses during operation.

(Continued on next page)

Hitching to Tractor (continued)

Hydraulic Connections

Before disconnecting hoses from tractor, place tractor in Park and shut PTO off, operate auger fold and pivot to the lowest positions. Where possible, remove hydraulic pressure loads and avoid potential pressure buildup in the lines from long storage periods such as upper auger not in rest position. If equipped with hydraulic jack, extend jack to desired position, turn valve to closed position. See tractor operator's manual for proper procedure to relieve pressure from the lines. After SCV pressures have been relieved and tractor engine is off, disconnect hoses from tractor. Install couplers into storage slots provided.

Fig. 3-8



Hitching to Tractor (continued)

Towing

Ensure that the towing vehicle has adequate weight and braking capacity to tow this implement. See towing vehicle manual for towing capacity. Never tow a loaded grain cart over public roads.

Maximum speed of cart should never exceed 20 m.p.h. Do not exceed 10 m.p.h. during off-highway travel. Do not exceed 8 m.p.h. when cart is fully loaded.

Secure drawbar pin with a locking device and lock tractor drawbar in centered position.

The PTO drive shaft needs to be placed in the storage position on the tongue or properly attached to the tractor. See “Coupling The Cut-Out Clutch” in SET UP section and “PTO Shaft and Clutch” in MAINTENANCE section before connecting the PTO drive shaft to the tractor.

Place transport chain through intermediate support and attach chain to tractor before towing.

CAUTION

- **THE STANDARD TRANSPORT CHAIN PROVIDED IS FOR THE BASIC CART WHEN TOWED EMPTY FOR ROAD TRAVEL.**

Regulate speed to road conditions and maintain complete control.

It is probable that this cart is taller, wider and longer than the towing tractor. Become aware of and avoid all obstacles and hazards in the travel path of the equipment, such as power lines, ditches, etc.

Slow down before making sharp turns to avoid tipping. Drive slowly over rough ground and side slopes.

Always fold auger into storage position when auger is not in use.

Hitching to Tractor (continued)

Electrical Connections

This cart is equipped with a seven-pin SAE connector plug which will connect with the receptacle found on most newer tractors. If your tractor does not have this type of receptacle, an SAE J-560 seven-point socket can be purchased from your Unverferth dealer (Part number 92824). (FIG. 3-9)

NOTE: 7-pin connector must be plugged into the tractor in order for the spout system to operate.

The wiring schematic for this cart, shown in the MAINTENANCE section, complies with AS-ABE Standards. Always verify correct electrical function before using this cart.

This unit is equipped with Side Marker lights for enhanced visibility. These lights will have different functionality depending upon the tractor lighting selection.

If the tractor field lights switch is on; the Side Marker lights and the amber turn signal lights are on solid and will not flash.

If the flashers and/or turn signal is on; the Side Marker lights flash in unison with their respective side's amber turn lamp.

Compliance with all lighting and marking laws is the responsibility of the operator at the time of travel.

See federal regulation 49 CFR 562; available at www.govinfo.gov for US federal law requirements.

See your Unverferth dealer for additional brackets, reflectors, or lights to meet your requirements.

Fig. 3-9

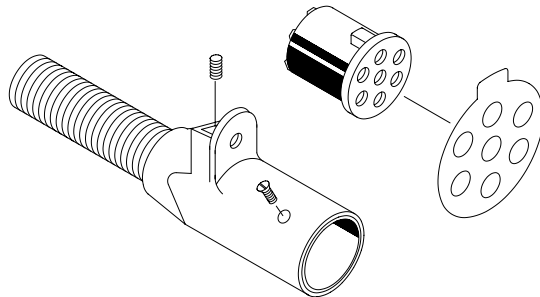

Electric Over Hydraulic Operation (Optional)

Before operating cart, familiarize yourself with the functions associated with the joystick controller by operating with an empty cart.

The joystick comes with a mounting pin allowing storage inside the tractor cab when not in use.

1. Connect the red wire from power harness (9008251) to a key-switched +12VDC power supply. (Fig. 3-10)
2. Connect the white wire from power harness (9008251) to ground. (Fig. 3-10)

Fig. 3-10

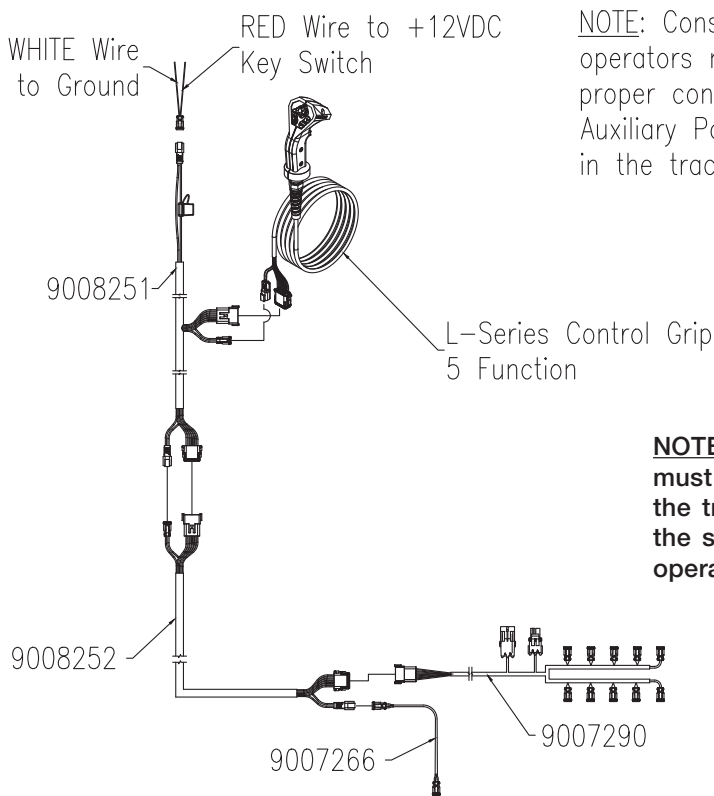

NOTE: Consult the tractor's operators manual for proper connection to the Auxiliary Power Outlet in the tractor cab.

NOTE: 7-pin connector must be plugged into the tractor in order for the spout system to operate.

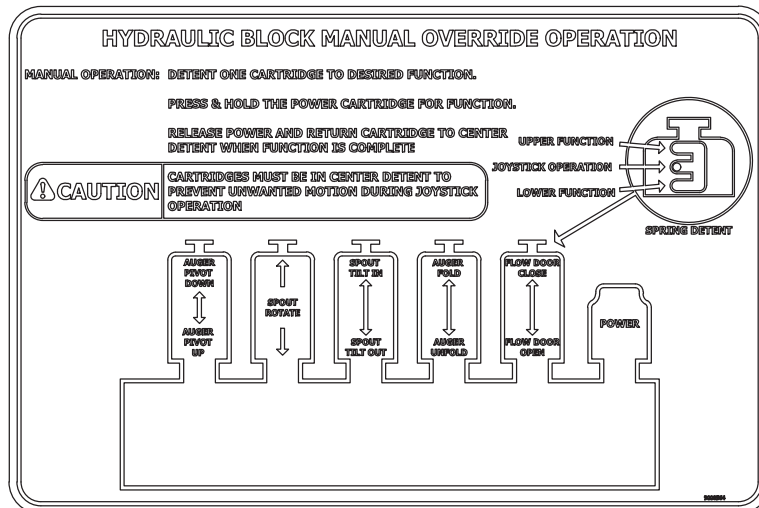

Electric Over Hydraulic Operation (Optional) (continued)

3. Connect the Hydraulic Pressure and Return hoses to the tractor SCV remote so that the Pressure line is able to be put in continuous detent.
4. Place the remote in continuous detent so that the Hydraulic Pressure hose is pressurized and set the hydraulic flow to a maximum 6 gal/min to minimum 4 gal/min.
5. To fold auger out from transport to operating position, push down the auger unfold button on joystick face until the upper and lower auger are engaged and fold linkage is over center.
See Fig. 3-11.

NOTE: Joystick has a double tap feature, which allows the operator to quickly double tap a function in order to operate it for a set time. If the auger fold or auger unfold buttons are double tapped, the function will stay on for 60 seconds to complete the full cycle without holding the buttons down. Pressing either of those buttons during these timed cycles will CANCEL the cycle. This double tap feature only applies to auger fold and unfold functions.

6. To tilt spout OUT away from cart, push hat switch toward OUT. Hold the switch until desired position is achieved. See Fig. 3-11.
7. To tilt spout IN toward cart, push hat switch toward IN. Hold the switch until desired position is achieved. See Fig. 3-11.
8. To pivot the entire auger UP, press and hold the auger pivot UP button until the desired height is achieved. See Fig. 3-11.
9. To pivot the entire auger DOWN, press and hold the auger pivot DOWN button until the desired height is achieved. See Fig. 3-11.
10. To pivot the spout FORWARD, push hat switch LEFT. Hold the switch until desired position is achieved. See Fig. 3-11.
11. To pivot the spout REARWARD, push hat switch RIGHT. Hold the switch until desired position is achieved. See Fig. 3-11.

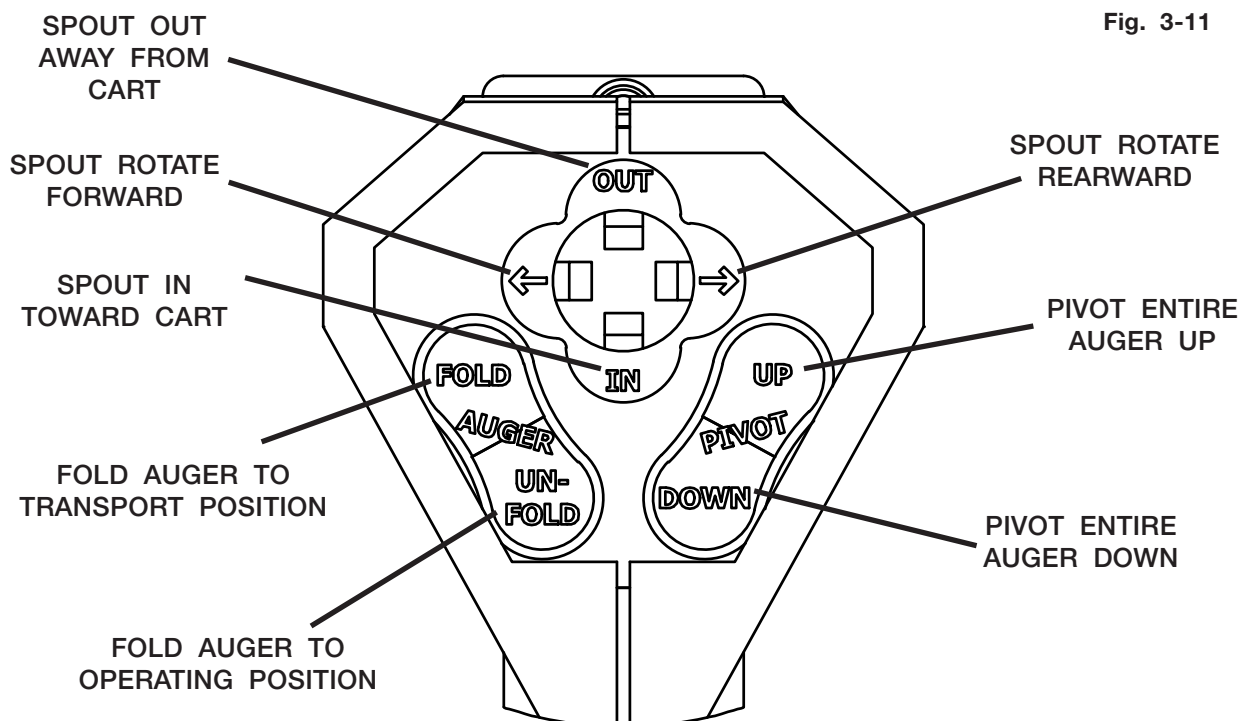

Electric Over Hydraulic Operation (Optional) (continued)

12. To open flow door, rotate the switch upwards. Observe flow door indicator to determine when to release trigger and stop flow door movement. See Fig. 3-12.

13. To close flow door, rotate the switch downwards. Observe the flow door indicator and release trigger when door is closed to desired position. See Fig. 3-13.

NOTE: Refer to “Troubleshooting” and “Auger Switch Troubleshooting” for EOH, vertical auger and/or rotating spout issues in the OPERATION section.

14. To fold auger from operating position to transport position:

A. Rotate spout to centered position. Align the checker flag with the upper auger and the spout rotate switch with the spout plate to locate center as shown in Figs. 3-14 and 3-15.

B. Press auger FOLD button on joystick.

C. Hold FOLD button until upper auger is on field rest or in transport position.

15. Once unloading is complete, stop hydraulic flow. **ALWAYS** stop continuous detent when auger functions are not required or active.

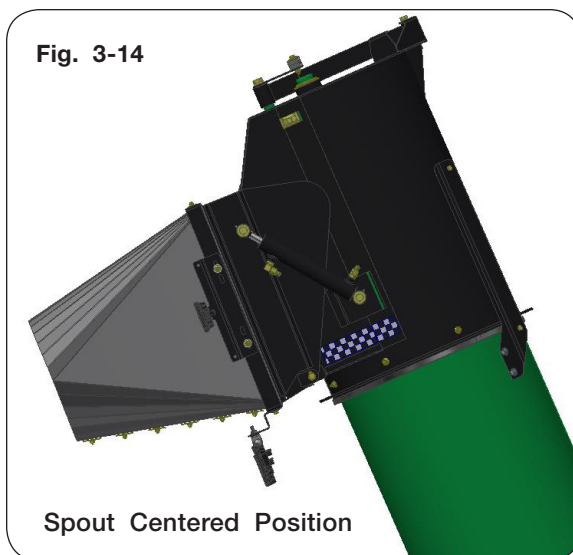
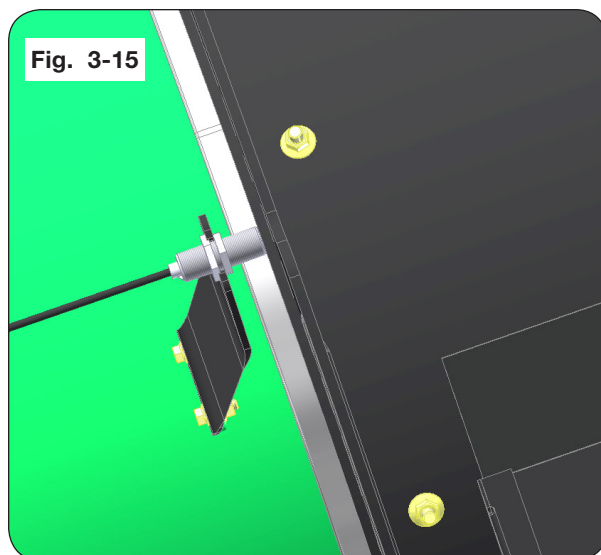
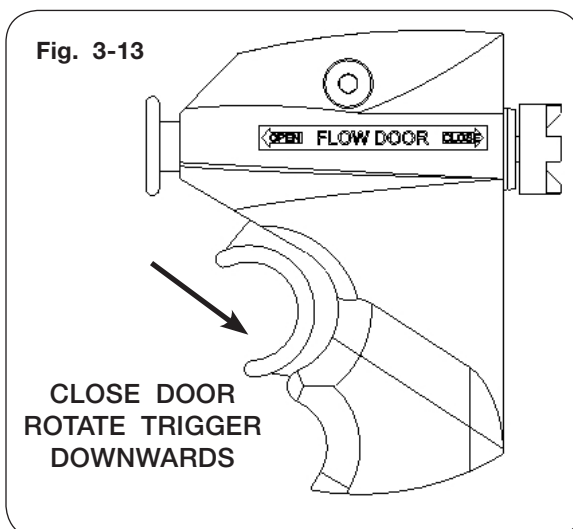
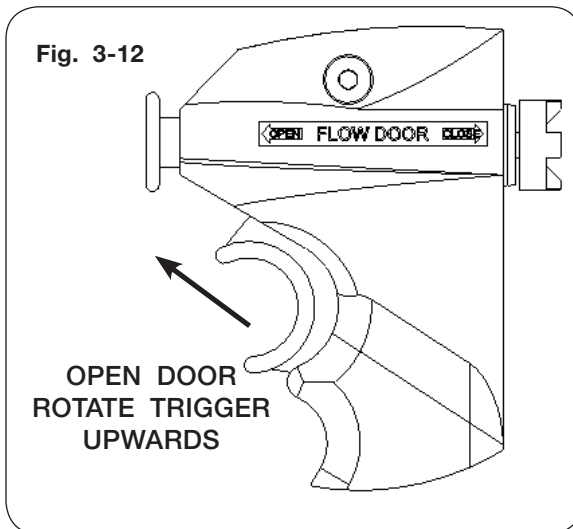

Manual Override for Optional Electric Over Hydraulic System

⚠ WARNING

- MOVING OR ROTATING AUGER COMPONENTS CAN CAUSE SERIOUS INJURY OR MACHINE DAMAGE. BEFORE OPERATING MANUAL OVERRIDE(S), ENSURE EVERYONE IS AWAY FROM THE SPOUT AND THAT THE SPOUT WILL NOT CONTACT ANY OTHER PARTS OF THE GRAIN CART. ALL CONTROL SWITCHES ARE DEACTIVATED WHILE UTILIZING MANUAL OVERRIDE(S).
- MOVING OR ROTATING PTO COMPONENTS CAN CAUSE SERIOUS INJURY OR DEATH. DO NOT OPERATE PTO WHILE UTILIZING MANUAL OVERRIDE(S).

NOTE: Manual override operation is intended for emergency use ONLY and is not intended for continuous operation.

NOTE: 7-pin connector must be plugged into the tractor in order for the spout system to operate.

1. Park the empty grain cart on a firm and level surface. Block the tires/tracks on the machine to keep it from moving. Set the tractor's parking brake.
2. Remove cover plate (272606B) from the bottom of the lower auger housing to access the EOH block assembly. Keep cover plate.
3. Connect the Hydraulic Pressure and Return hoses to the tractor SCV remote so that the Pressure line is able to be put in continuous detent.

NOTE: Center rotating spout before activating auger fold.

4. To operate the manual override functions, place the tractor SCV remote in continuous detent so that the Hydraulic Pressure hose is pressurized.

NOTE: Only one cartridge valve (9008416 & 9008463) must be in the top or bottom detent position at a time to function properly. All other valves must be in the middle detent position. (FIG 3-16 & 3-17)

5. Operate the desired function on valve (9008416 & 9008463) by rotating the manual override knurled knob from the locked neutral position. (FIG. 3-16 & 3-17)

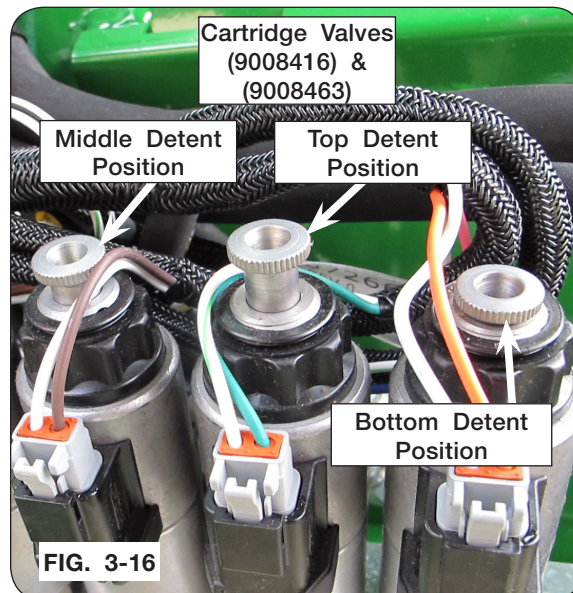

FIG. 3-16

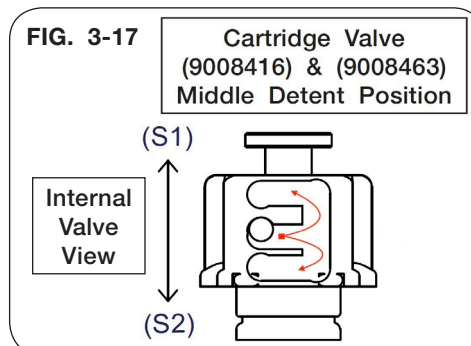

FIG. 3-17

Manual Override for Optional Electric Over Hydraulic System
(continued)

6. Push and hold the manual override button on valve (9008438). (FIG. 3-18)
7. Once the desired position is reached, release manual override button on valve (9008438).
8. Return knurled knob to center and lock valve (9008416) & (9008463) in position. (FIG. 3-16 & 3-17)

NOTE: Refer to “Troubleshooting” and “Auger Switch Troubleshooting” for EOH, vertical auger and/or rotating spout issues in the OPERATION section.

9. Turn off hydraulic circuit when done. Correct electric/hydraulic system before continued use. Consult your dealer for service and parts.

10. Replace cover plate (272606B) from step 2 to the bottom of the lower auger housing.

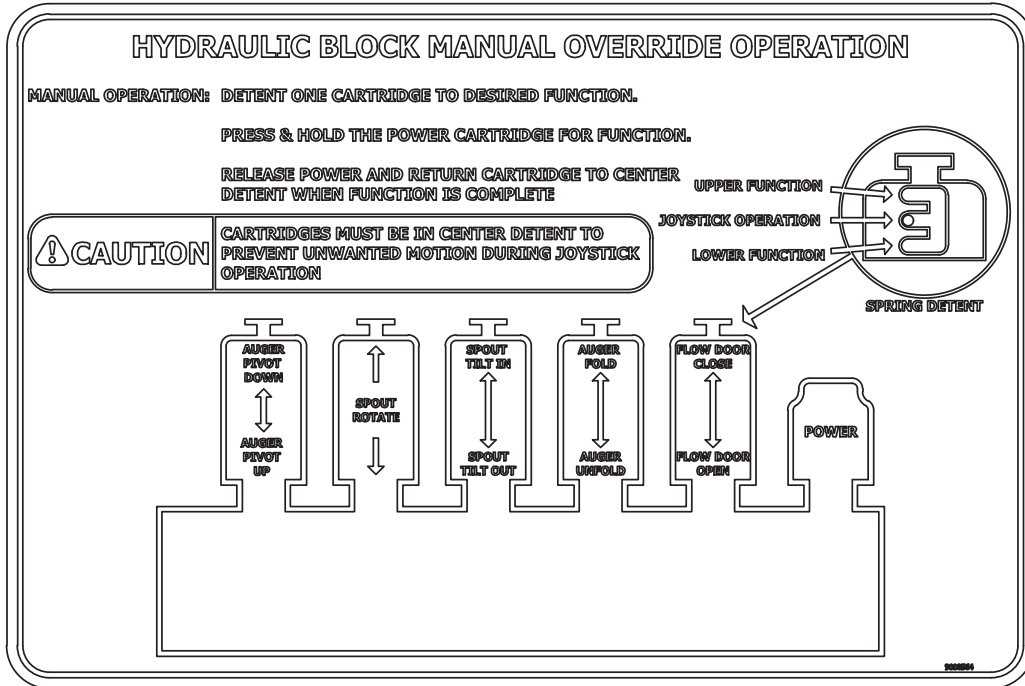
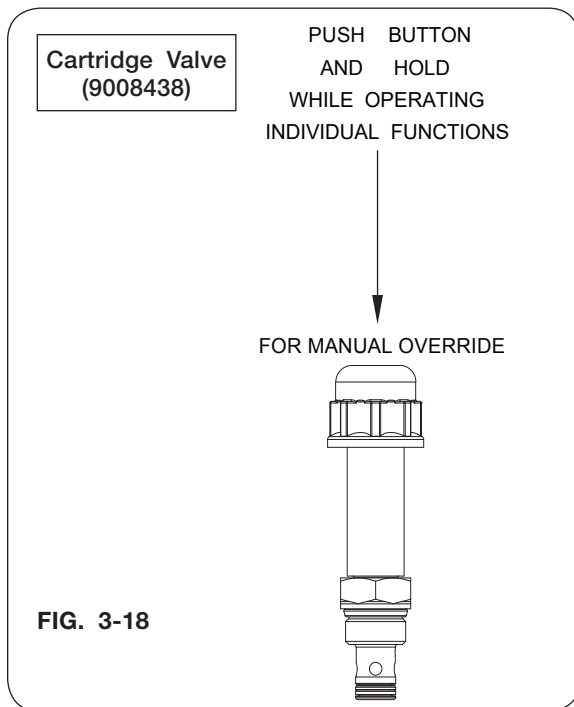

Vertical & Horizontal Cleanout Door Operation

⚠ WARNING

- MOVING OR ROTATING COMPONENTS CAN CAUSE SERIOUS INJURY OR DEATH. ENSURE SERVICE COVERS, CHAIN/BELT COVERS AND CLEANOUT DOORS ARE IN PLACE AND SECURELY FASTENED BEFORE OPERATING UNIT.
- KEEP HANDS CLEAR OF PINCH POINT AREAS.
- TIPPING OR MOVEMENT OF THE MACHINE CAN CAUSE SERIOUS INJURY OR DEATH. BE SURE THE MACHINE IS SECURELY BLOCKED.
- EYE PROTECTION AND OTHER APPROPRIATE PERSONAL PROTECTIVE EQUIPMENT MUST BE WORN WHILE SERVICING THE IMPLEMENT.

Opening Vertical Cleanout Door

1. Pivot the vertical auger all the way up to open, close and remove the cleanout door from the vertical lower auger.
2. Park the empty grain cart on a firm and level surface. Block the tires/tracks on the machine to keep it from moving. Set the tractor's parking brake, shut-off the engine, remove the ignition key and disconnect the PTO shaft.

NOTE: Remove the vertical auger cleanout door to improve vertical auger cleanout.

3. To open and remove the vertical auger cleanout door, unclasp the over-center latch. (FIG. 3-19)
4. Unhook the eye bolt from the vertical auger and open the cleanout door. (FIG. 3-19)
5. The hinge on the vertical auger cleanout door is set on a pin. Lift and remove the cleanout door from the vertical auger. Keep vertical auger cleanout door. (FIG. 3-20)
6. Inspect and verify all debris is removed from inside the vertical auger housing.
7. Reattach the vertical cleanout door to the vertical auger.

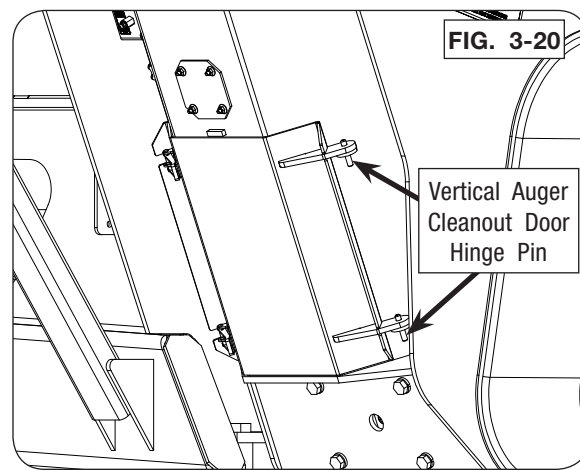
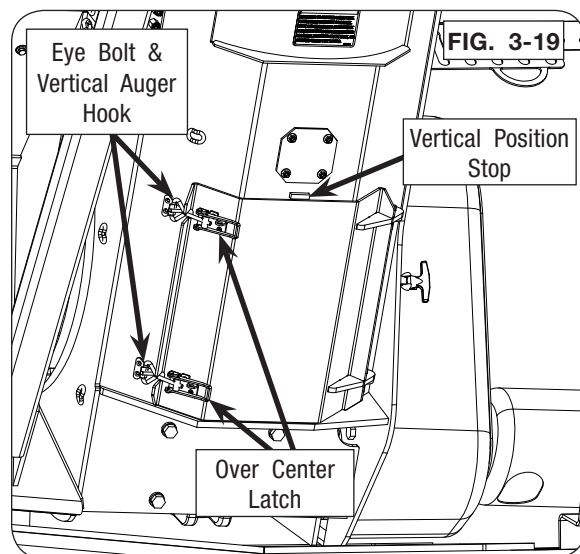

Vertical & Horizontal Cleanout Door Operation

Closing Vertical Cleanout Door

1. Pivot the vertical auger all the way up to open, close and remove the cleanout door from the vertical lower auger.
2. Park the empty grain cart on a firm and level surface. Block the tires/tracks on the machine to keep it from moving. Set the tractor's parking brake, shut-off the engine, remove the ignition key and disconnect the PTO shaft.
3. To completely close cleanout door, ensure the vertical auger cleanout door top edge clears the vertical position stop (key stop). (FIG. 3-21)
4. Attach eye bolt ends of over-center latches to the hooks on the vertical auger. (FIG. 3-21)
5. Engage the over-center latch handles to lock the door in the closed position. (FIG. 3-21)
6. Inspect and verify cleanout door perimeter for gaps. Ensure all grain dust and filings are removed that may prevent the door from shutting completely.
7. If gaps are present, unclasp the over-center latch and tighten eye bolt to improve door seal contact on the vertical auger.
8. Rehook eye bolt to vertical auger and engage the over center latch.

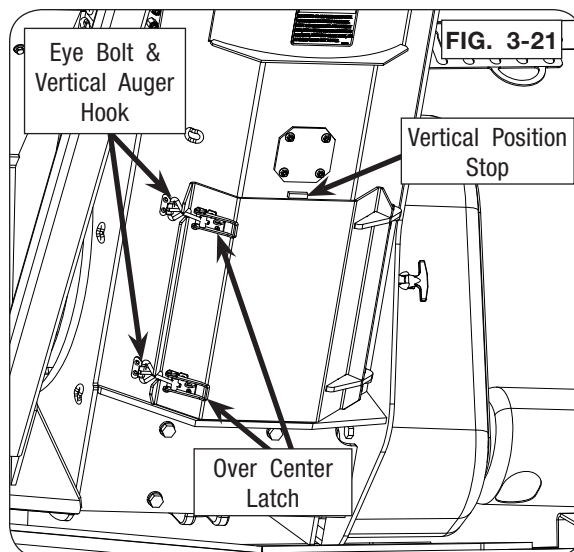

NOTE: Repeat closing the door and inspection as necessary.

Vertical & Horizontal Cleanout Door Operation (continued)

Horizontal Cleanout Door

Use the tensioner handle, located on the left-hand side of the grain cart, behind the first panel to open and close the horizontal cleanout doors.

1. Insert tensioner handle into the cleanout door receiver coupler on the rear panel, and remove lynch pin from rockshaft. Keep lynch pin. (FIG. 3-22)
 2. Rotate the tensioner handle clockwise to open the cleanout doors. (FIG. 3-23)
 3. Insert and lock lynch pin into rockshaft. (FIG. 3-23)
 4. Inspect and verify all debris is removed that may prevent the doors from shutting completely. (FIG. 3-24)
- NOTE:** If cleanout doors do not function properly, refer to “Horizontal Cleanout Door Inspection” in SET UP section for more information.
5. Remove lynch pin from rockshaft and rotate handle counter-clockwise and clockwise to check for smooth door operation.

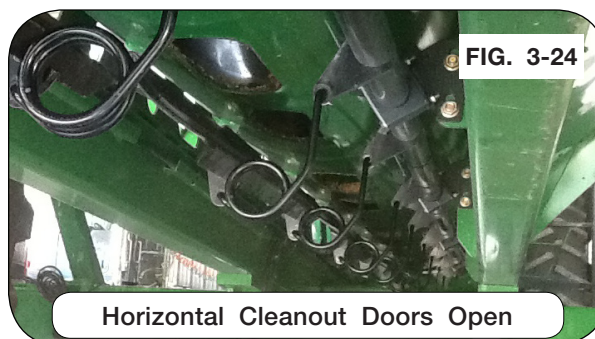
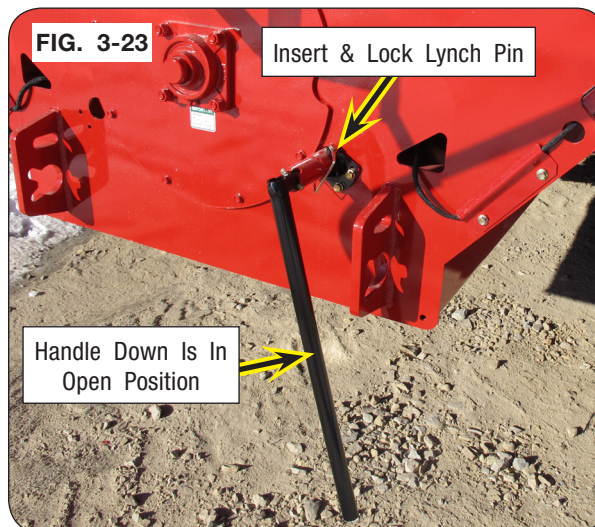
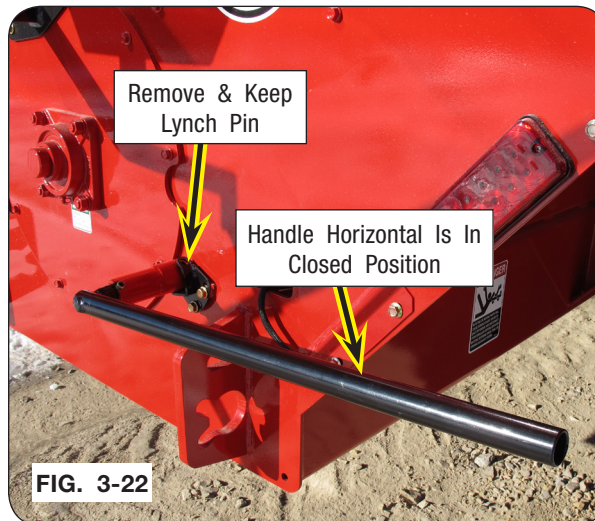

Vertical & Horizontal Cleanout Door Operation (continued)

Horizontal Cleanout Door

6. Rotate handle counter-clockwise to close doors and ensure all doors seal. (FIG. 3-25)

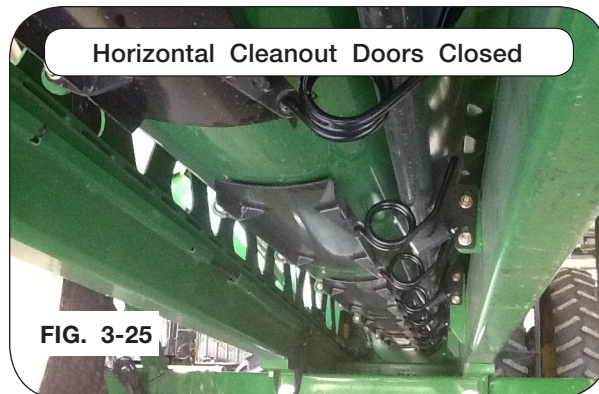

7. Insert and lock lynch pin into rockshaft and return handle to storage location. (FIG. 3-26)

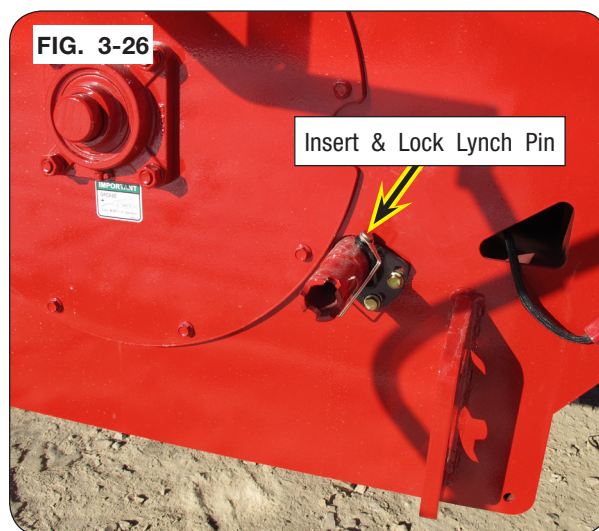

Auger Operation

PTO Driven Auger

DANGER

- ELECTROCUTION WILL CAUSE SERIOUS INJURY OR DEATH. ELECTROCUTION CAN OCCUR WITHOUT DIRECT CONTACT. KEEP AWAY FROM ALL ELECTRICAL LINES AND DEVICES.



WARNING

- NEVER ENTER CART WITH AUGER OR TRACTOR RUNNING. SERIOUS OR FATAL INJURY CAN OCCUR DUE TO ENTANGLEMENT WITH ROTATING COMPONENTS. ALWAYS STOP ENGINE AND REMOVE KEY BEFORE ENTERING CART.
- TO PREVENT PERSONAL INJURY OR DEATH ALWAYS ENSURE THAT THERE ARE PEOPLE WHO REMAIN OUTSIDE THE CART TO ASSIST THE PERSON WORKING INSIDE, AND THAT ALL SAFE WORKPLACE PRACTICES ARE FOLLOWED. THERE ARE RESTRICTED MOBILITY AND LIMITED EXIT PATHS WHEN WORKING INSIDE THE IMPLEMENT.

1. Before loading cart or operating auger, verify that the flow control door is closed.

NOTE: If spout rotate moves out of center, the auger will not unfold to unloading position. The spout must be manually rotated to center position. See “Manual Override for Optional Electric Over Hydraulic System” in the OPERATION section.

2. Choose an area free from obstructions and unfold auger into unloading position. Allow sufficient time for the cylinder to fully engage the two augers and over-center latch to fully engage.
4. Engage PTO at low engine RPM, then increase engine RPM until 1000 PTO RPM is reached.
5. Open flow control door to desired unloading rate. Numbers on the auger tube provide a point of reference for operator convenience. (FIG. 3-27)
6. To slow or stop grain flow, close flow door, rather than reducing tractor RPM. Close flow door fully when unloading is complete.

NOTE: If an overload occurs, see “Auger Overload Procedure.”

NOTE: It is not recommended to disengage auger with flow control door open. Auger system will require substantially more torque to start, placing extra stress on both cart and tractor driveline.

Cart is equipped with baffles that can be adjusted to accommodate the flow of different materials and/or torque demands associated with different materials. See the MAINTENANCE section for the procedure.

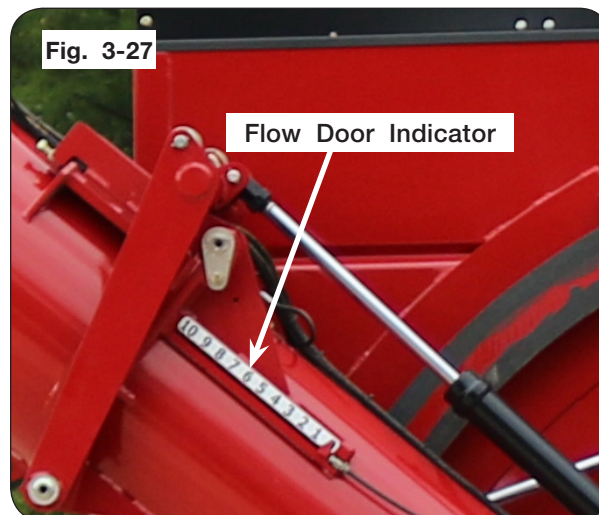

Fig. 3-27

Flow Door Indicator

Auger Operation (continued)

7. When auger is empty, reduce PTO rpm to idle, and stop PTO.
8. After PTO has come to a complete stop, the checker flag needs to align with the upper auger and align the spout rotate switch with the spout plate to center spout as shown in FIG. 3-28 and 3-29.
9. Once spout is centered, fold auger to the transport position or field position.

NOTE: Spout can be TILTED to any position, but must be ROTATED to center for auger to fold.

Fig. 3-28

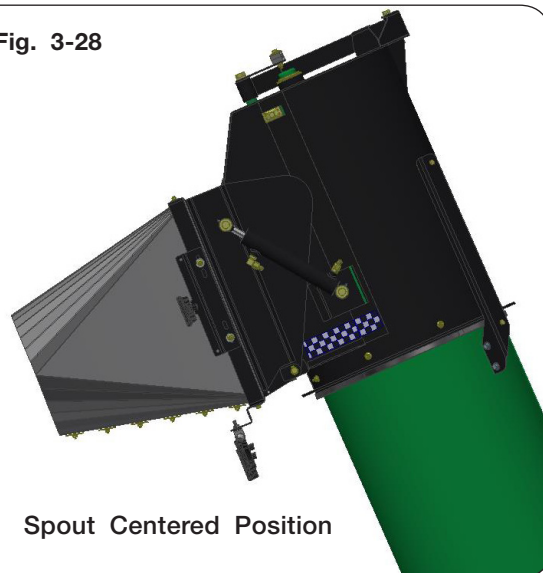
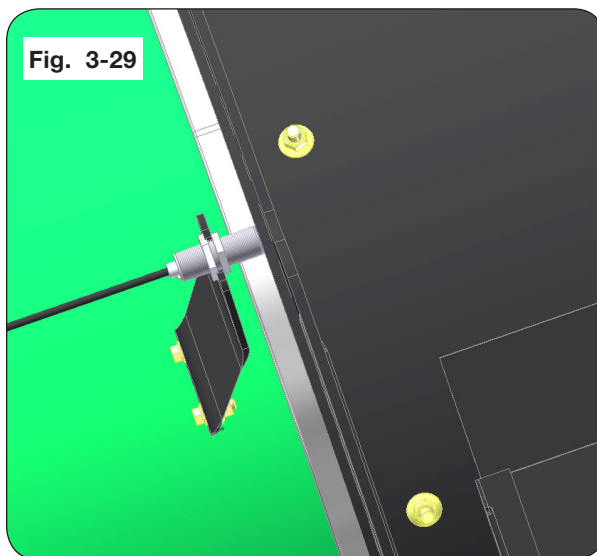

Fig. 3-29



Auger Operation (continued)

Auger Overload Procedure

IMPORTANT

- Extensive operation while the clutch is slipping may damage drive components.

NOTE: When over loading occurs, drivelines equipped with cut-out clutch will make a “clicking” noise when torque has been exceeded. Immediately shut off PTO and shut the flow door.

NOTE: Once PTO RPM has significantly decreased, cut-out clutch will automatically reset.

1. Close flow door.
2. With the PTO off and driveline stopped, disengage the belt tensioner using the belt tensioner handle, this disengages the horizontal auger from the drivetrain. (FIG. 3-30)
3. Restart and engage the tractor PTO at low engine RPM.
4. Increase engine RPM until 850 to 1,000 PTO RPM is reached to empty the vertical auger.
5. Once vertical auger is empty, stop PTO.
6. With the tractor PTO off and driveline stopped, reengage the belt tensioner using the belt tensioner handle. Return handle to storage. (FIG. 3-31)
7. Restart and engage the tractor PTO at low engine RPM.
8. Increase engine RPM until 850 to 1,000 PTO RPM is reached to empty the drag auger.

NOTE: If the grain cannot be relieved by above method, open bottom clean out doors (see “Vertical & Horizontal Clean-Out Door Operation” in this section) to remove grain from auger before repeating these steps to clean out auger.



Auger Operation (continued)

Vertical Auger Fold

WARNING

- DO NOT STAND ON LADDER OR FRAME UNLESS TRACTOR ENGINE IS TURNED OFF AND KEYS ARE REMOVED FROM THE IGNITION.

Actuate hydraulic auger fold circuit to pivot vertical auger between transport and operating positions. When unfolding auger, allow sufficient time for cylinder to rotate the outside fold link into an over-center position.

NOTE: Auger spout will not rotate until auger is fully extended and auger will not fold until the spout is centered. It may be necessary to manually rotate auger spout in order to unfold the auger. See “Manual Override for Optional Electric Over Hydraulic System” in the OPERATION section for details.

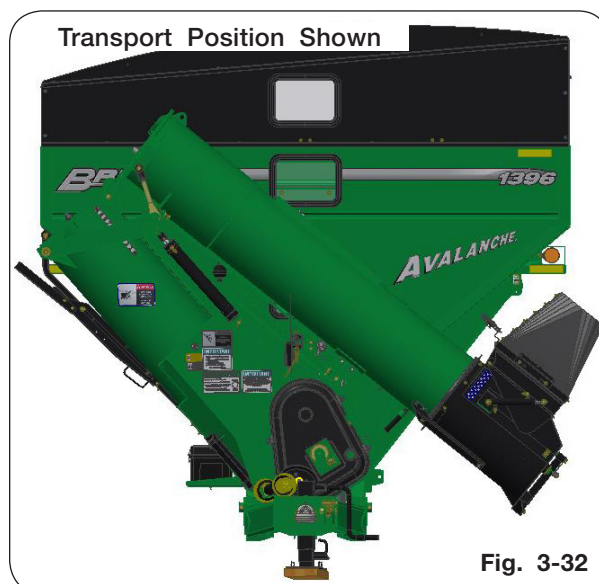

Auger Operation (continued)

Auger Field Rest Position

IMPORTANT

- Auger field rest is **ONLY** for use in the field. Auger must be folded to transport position during transport.
1. Extend auger to the unload position. Shut-off tractor's engine and remove the ignition key.



2. Remove hairpin cotter from latch pin (Figure 3-33) and pull latch pin to disengage (Figure 3-34). Raise auger rest stand up to field position and release latch pin. Make sure the pin is engaged in the field position hole and re-install hairpin removed earlier in this step.
3. Fold auger back to field rest position (Figure 3-35), making sure bracket engages the auger rest tube and activates the auger switch.

NOTE: Auger rest bracket is factory adjusted. Capscrews can be used for re-alignment of bracket. See Fig. 3-35.

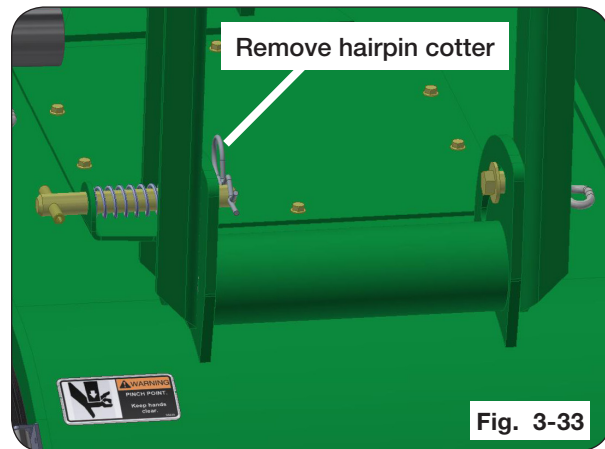

Fig. 3-33

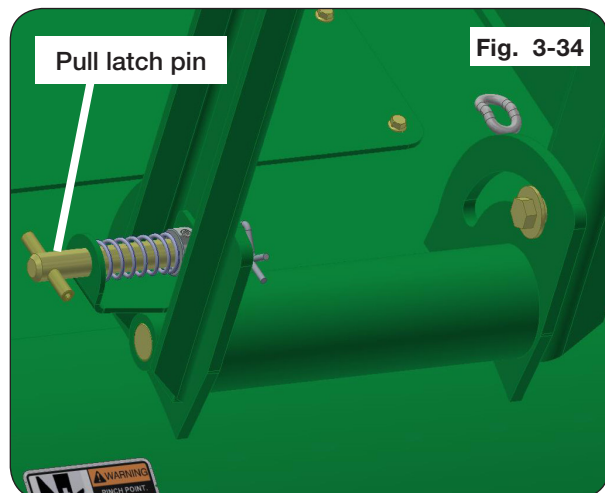

Fig. 3-34

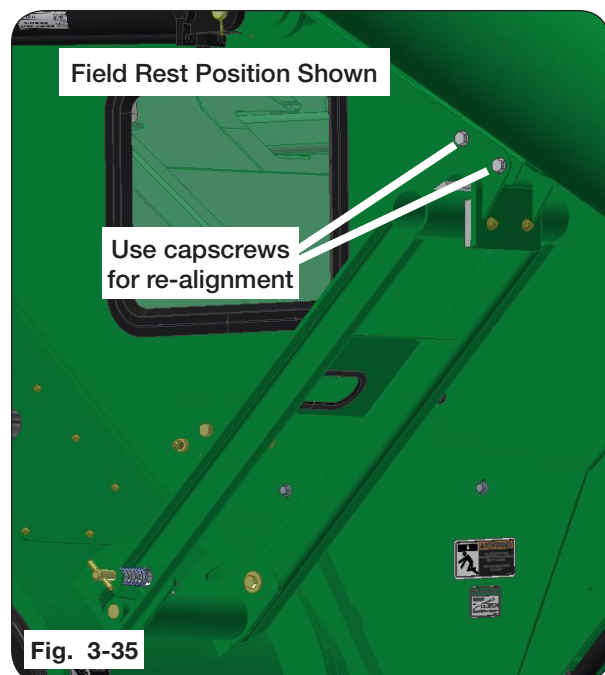
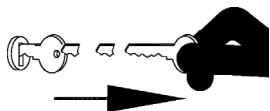

Fig. 3-35

Auger Operation (continued)

Auger Transport Position

1. Extend auger to the unload position. Shut-off tractor's engine and remove the ignition key.



2. Remove hairpin and pull latch pin towards you to disengage. Lower auger rest stand to the transport position and release the latch pin (Figure 3-36). Make sure the pin is engaged in the transport position hole and re-install hairpin removed earlier in this step.

3. Fold auger down to transport position. (Figure 3-37)

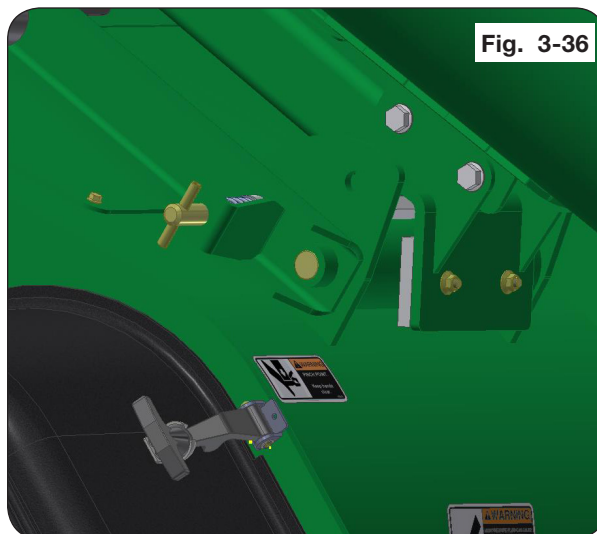

Auger Operation (continued)

Upper Auger Rest Adjustments

1. Loosen mounting capscrews of auger rest bracket. (Figure 3-38)
2. Raise auger approximately 6" out of the lower rest and install cylinder stops on the fold cylinder to prevent the auger from lowering unexpectedly.
3. Position upper auger rest as needed so that it appears to be centered over the lower auger rest tube.
4. Hand tighten the mounting capscrews of the auger rest bracket.
5. Remove the cylinder stops installed in step 2, and lower the auger down into the lower rest.
6. Ensure the upper auger rest contacts the lower tube evenly.
7. Torque mounting capscrews to 65 ft.-lbs.

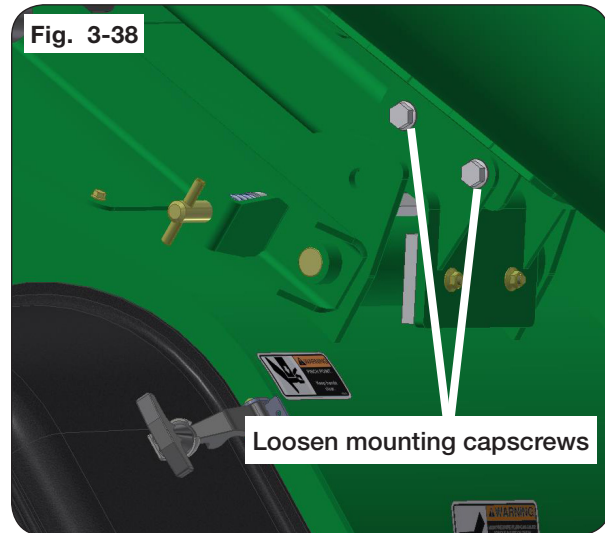

Troubleshooting

Problem	Possible Cause	Corrective Action
No Electric Over Hydraulic (EOH) Functions work	Not getting 12 volt power supply to the power harness in the tractor	Check the connections to the main power harness in the tractor cab, and check the 5 AMP fuse in the fuse holder of the main power harness. Replace fuse if necessary.
	Not getting good connection at Deutch connectors in the harnesses	Unplug the Deutsch connectors at the hitch point and in the extension harness (if used). Clean up the connectors with electrical contact cleaner. Make sure the connectors are aligned correctly and re-connect them.
	Not pressurizing the correct hydraulic hose	Make sure the quick couplers are properly connected to the tractor SCV and the Hydraulic Pressure line is being pressurized when engaging the tractor SCV.
Auger unfolds, but won't fold back in to transport position	Rotating Spout is not in the folding position	Rotate the spout so it is positioned straight down or forward in order to fold the auger into transport position.
	Rotating spout switch is faulty or out of adjustment	Make sure the spout is in the centered position. Press and hold the manual override button on the electric over hydraulic (EOH) valve on the auger fold cylinder while someone operates the hydraulic remote to fold the auger back to the transport position. Inspect the switch assembly near the rotating spout cylinder. The clearance between the end of the proximity switch and spout plate of the rotating spout assembly must not exceed 1/4".
Auger unfolds part way and stops OR Auger will not unfold	Debris in the EOH block on the auger fold cylinder	Remove the Coil and the cartridge valve on the EOH valve block. Remove any debris and reinstall cartridge and coil.
	Rotating Spout switch is out of adjustment or has been activated.	With the auger folded in to the lower field rest or lower rest, have someone depress and hold the switch at the vertical auger hinge plate. Use any means necessary to depress the switch without placing your hands or other body parts near the pinch points. With the switch depressed, rotate the spout to the folding position.

Brent 1196/1396 Right-Hand Unload — Operation

Troubleshooting (continued)

Problem	Possible Cause	Corrective Action
Spout rotate does not operate	7 pin connector is not plugged into tractor.	Plug in 7 pin connector to same power source as the 5 function controller.
	Proximity Switch at the auger hinge is not getting Power or Ground.	Check power and ground to the proximity switch harness on the vertical auger.
Rotating spout will not function	Proximity Switch at the hinge plate is not adjusted correctly	This proximity switch has a 1/4" effective operating range. The upper auger hinge plate needs to be within that range when it is unfolded in to the operating position. Adjust the proximity switch in or out in order for the sensor to activate when it is in the operating position.
	Switch located at the hinge plate of the vertical auger is not getting power, ground or is defective	Check the ground wire on the top plate of the lower vertical auger and on the left hand standard just behind the front plate of the harness. Unplug the 3 pin connector on the hinge plate proximity switch. With a multi-meter or test light, confirm that the pin in socket B has +12V constant power and socket A has +12V when the sensor is activated.
One single function will not work	Defective coil on the EOH valve for that function	Loosen the cap for the coils associated with that function on the EOH valve. Depress the button on the remote, and determine if the coils are getting magnetized. Inspect the wiring connectors to these coils, and replace the coil if necessary.
	Defective valve on the EOH valve for that function	Remove the coil and the cartridge valve on the EOH valve block for that function. Replace the valve if it doesn't operate when the coil is magnetized.
	Debris in the EOH block at the base of the vertical auger	Remove the coil and the cartridge valve on the EOH valve block. Remove any debris and reinstall cartridge and coil.
Functions continue to operate after the button on the remote is released	Tractor hydraulic flow is set too high	Turn tractor hydraulic flow down so that flow doesn't exceed 6 gallons per minute.
	Defective valve on the EOH valve for that function	Remove the Coil and the cartridge valve on the EOH valve block for that function, and replace the cartridge.

Auger Switch Troubleshooting

The switch on the upper auger near the spout controls the ground for both the spout rotate front and rear. The switch near the auger hinge pin controls the ground for both the auger fold and the auger unfold. Check continuity between the switch wires to determine if the switches were out of adjustment. Adjust accordingly if needed.

The switch at the spout must have no more than a 1/4" gap between the spout plate and the switch. Verify the gap if the auger fold stops functioning during the auger fold sequence or if the auger folds even if the spout is rotated back and allows the spout to hit the hopper while folding. (Fig. 3-39)

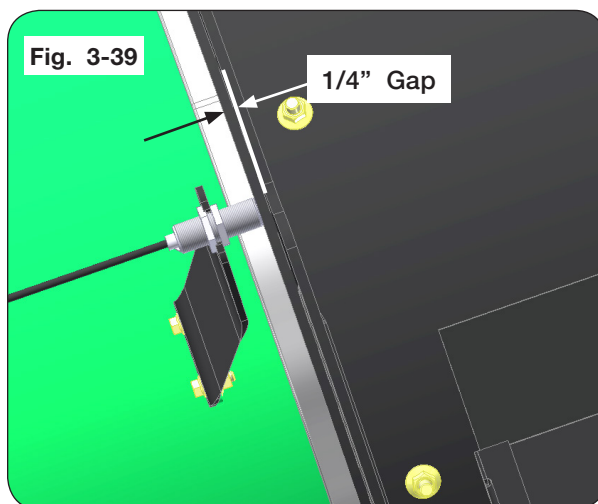

The switch at the hinge pin should be adjusted so there is 1/8" gap below the lower auger hinge plate. To maintain the 1/8" gap, adjust the hinges on the upper auger or by turning the switch in or out until the 1/8" gap is achieved. (Fig. 3-40)

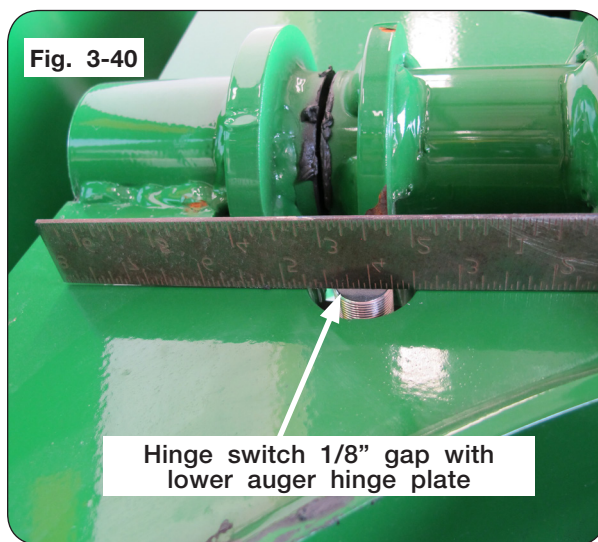

Ladder Operation

WARNING

- **FALLING OR LOWERING EQUIPMENT CAN CAUSE SERIOUS INJURY OR DEATH. KEEP EVERYONE AWAY FROM EQUIPMENT WHEN SUSPENDED, RAISING, OR LOWERING.**
- **KEEP HANDS CLEAR OF PINCH POINT AREAS.**
- **DO NOT ALLOW ANYONE TO RIDE ON THE LADDER. MAKE SURE EVERYONE IS CLEAR BEFORE OPERATING MACHINE OR TOWING VEHICLE.**
- **TO PREVENT PERSONAL INJURY OR DEATH, ALWAYS ENSURE THAT THERE ARE PEOPLE WHO REMAIN OUTSIDE THE CART TO ASSIST THE PERSON WORKING INSIDE, AND THAT ALL SAFE WORKPLACE PRACTICES ARE FOLLOWED. THERE ARE RESTRICTED MOBILITY AND LIMITED EXIT PATHS WHEN WORKING INSIDE THE IMPLEMENT.**
- **NEVER ENTER A CART CONTAINING GRAIN. FLOWING GRAIN TRAPS AND SUFFOCATES VICTIMS IN SECONDS.**

NOTE: Ensure ladder and steps are free from snow/debris before changing ladder positions and climbing.

NOTE: Ensure upper ladder extension is attached to higher holes on the ladder. Reference “Upper Ladder Extension to Operating Position” section in the SET UP section.

NOTE: Always use lock pin in the working and storage position to lock the ladder extension. The lock pin can be inserted in either left-hand or right-hand ladder hole. (FIGS. 3-41 & 3-42)



Ladder Operation (continued)

Storage to Working Position

1. Standing in front of ladder, place hands on outside ladder handles.
2. Keep one hand on ladder handle and with opposite hand, remove lock pin from ladder extension. Retain for future use. (FIG. 3-43)
3. With hands back on ladder handles, push ladder towards hopper bin and lift ladder extension to unseat ladder extension rod from the cradle. (FIG. 3-44)

CAUTION

- THE LADDER IS NOW FREE TO PIVOT.

4. Slowly swing ladder outward until hinge is fully extended and locks in the working position. (FIG. 3-45)

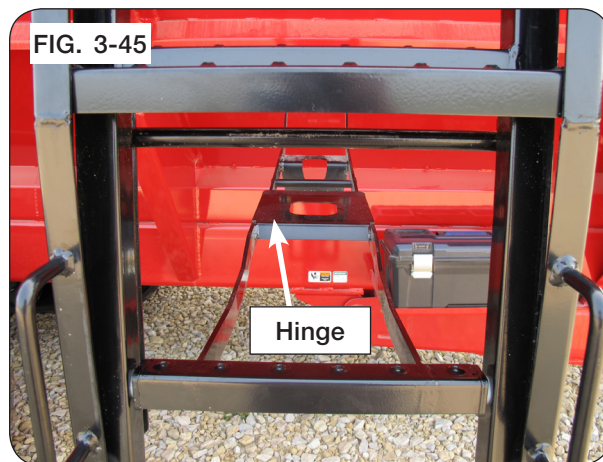
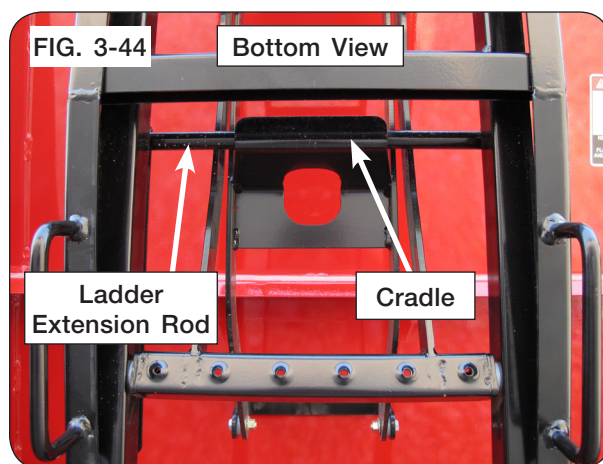
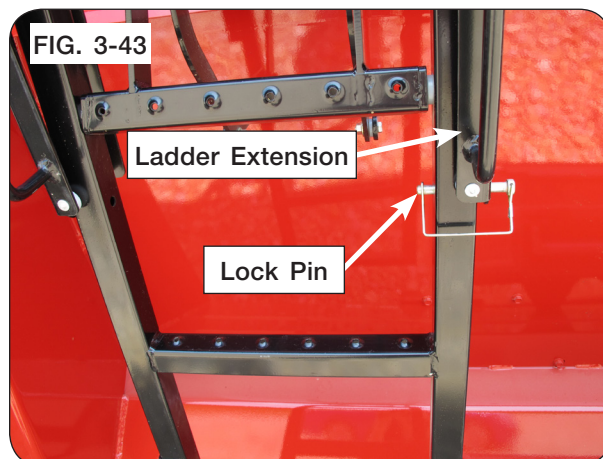

Ladder Operation (continued)

Storage to Working Position

5. Lift and seat ladder extension into shorter leg of “J slot”. (FIG. 3-46)
6. Using lock pin from step 2, insert lock pin into ladder extension and ladder. (FIG. 3-46)

WARNING

- **FALLING FROM AN UNSECURED LADDER MAY CAUSE SERIOUS INJURY OR DEATH. ALWAYS INSERT LOCK PIN BEFORE CLIMBING.**

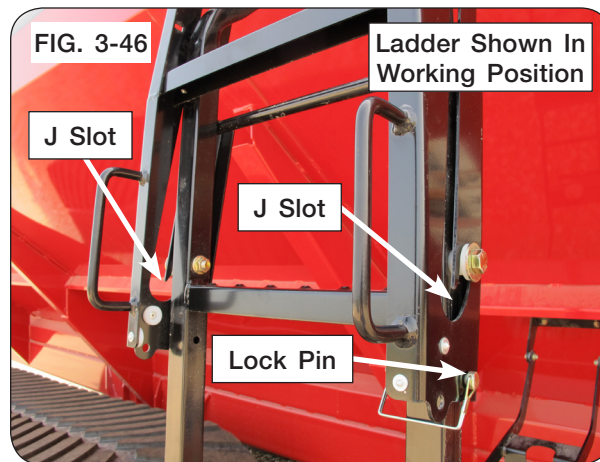

Working to Storage Position

7. Standing in front of ladder, place hands on outside ladder handles.
8. Keep one hand on ladder handle and with opposite hand, remove lock pin from ladder extension. Retain for future use. (FIG. 3-46)
9. With hands back on ladder handles, lift and unseat ladder extension from shorter leg of “J slot”. (FIG. 3-46)
10. Lower ladder extension until fully seated in longer leg of “J slot”. (FIG. 3-47)

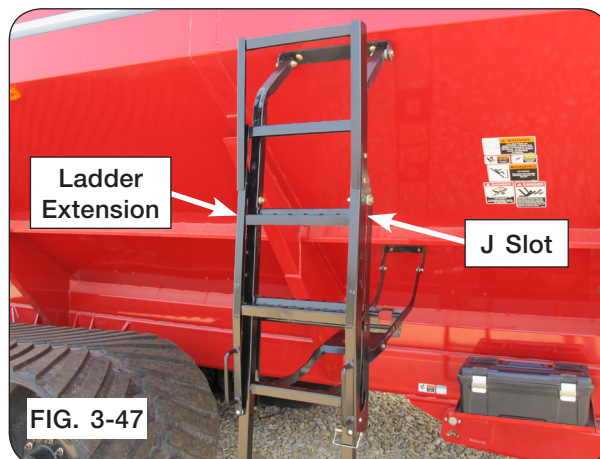

11. Keep one hand on ladder handle and with opposite hand, reach between ladder rungs and grab the ladder hinge hole. (FIG. 3-48)
12. Slowly lift ladder hinge until the ladder starts folding.
13. Remove hand from ladder hinge hole and place onto ladder handle.
14. Slowly push ladder towards hopper bin.

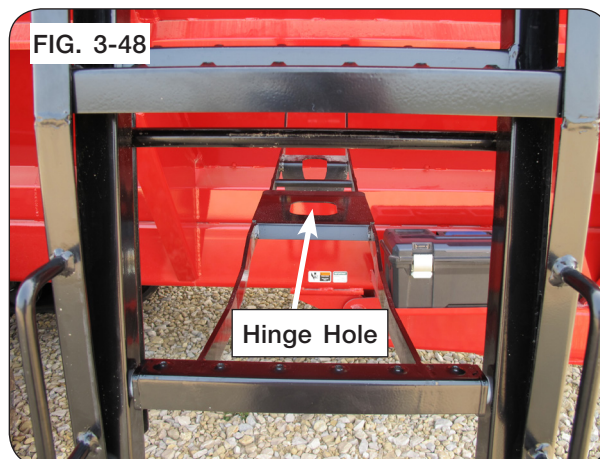

Ladder Operation (continued)

Working to Storage Position

15. Lower ladder extension and seat ladder extension rod onto the cradle. (FIG. 3-49)

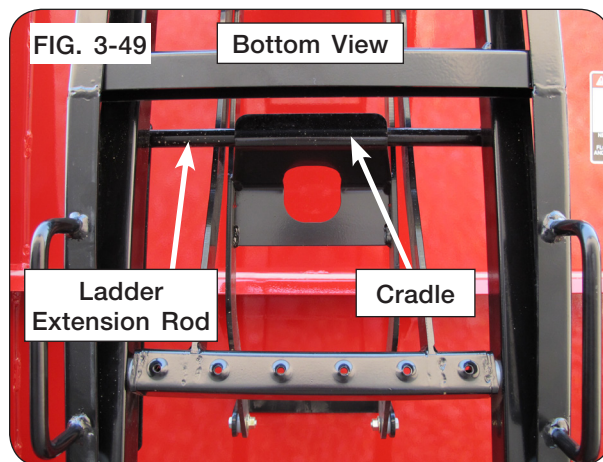

16. Using lock pin from step 8, insert lock pin into ladder extension and ladder. (FIG. 3-50)

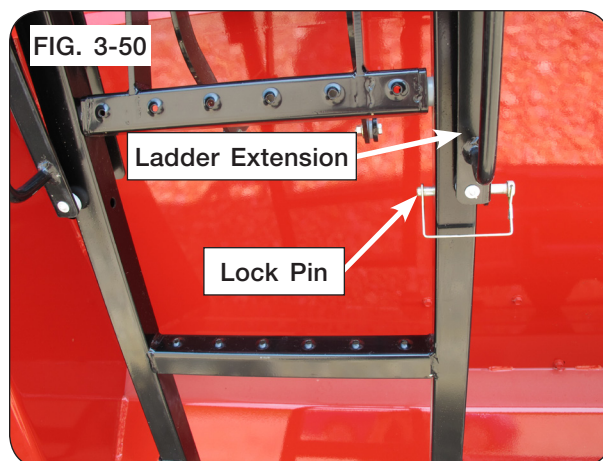

Weather Guard Tarp

WARNING

- **TO PREVENT PERSONAL INJURY OR DEATH, DO NOT ALLOW ANYONE ON A CLOSED TARP. TARP SYSTEM IS NOT DESIGNED TO SUPPORT A PERSON.**
- **FALLING OBJECTS CAN CAUSE SERIOUS INJURY OR DEATH. REMOVE ACCUMULATED WATER/SNOW/ICE OR ANY OTHER OBJECTS FROM TARP BEFORE OPENING TARP.**

IMPORTANT

- *Do not open or close tarp while moving or in high wind conditions. Damage to the tarp may occur.*
- *Tarp should not be used if it is torn or the bungee cords are frayed or show damage. If water pools on the tarp, adjust tension of tarp cables and/or arm springs as required.*

Always use adequate caution when operating tarp.

Make sure tarp is open before unloading or loading.

Make sure nobody is near the tarp system before and during operating.

Do not operate tarp with cart hoisted in an elevated position.

If tarp is covered with snow, it is important to remove snow before operating.

End caps must be free from grain that may be piled on them. Grain should not be heaped higher than the end caps or tarp bows.

Tarp may be fully opened or completely closed while in transit. However, the closed position is recommended.

Ensure everyone who operates the tarp is familiar with the correct procedures outlined in this manual.

Weather Guard Tarp (continued)

1. Using both hands, carefully remove crank from holder. (FIG. 3-51)
2. Roll tarp to the desired location, choosing either a fully open or fully closed position.
3. To close the tarp, roll the main tarp tube clockwise up under the latch plate. Next, bring the crank handle down perpendicular to the ground. Continue by lifting it up into the crank retainer.

NOTE: Crank U-joint may need to be re-indexed on tarp tube to achieve correct tension.

4. Place crank in holder.
5. To open tarp, turn the main tarp tube counter clockwise until the tarp is fully open. Place crank in crank holder.

FIG. 3-51

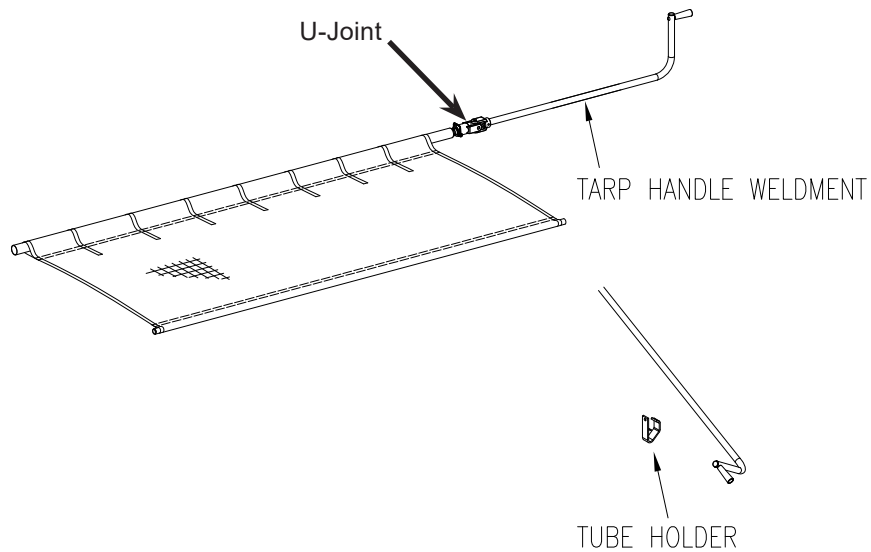

Notes

Section IV Maintenance

Lubrication - Cart	4-2
Hydraulic System	4-4
Purge Hydraulic System	4-4
Relieving Hydraulic Pressure	4-5
Purging Procedure For EOH System.....	4-5
Walking Tandem Option	4-6
Inner Dual Wheel Access	4-6
Row Spacing Adjustment.....	4-7
Seasonal Storage	4-8
Gearbox Sight Glass	4-9
Driveline Removal	4-9
Clamping Cone Assembly.....	4-9
Auger Driveline Bearings	4-10
Baffle Adjustment.....	4-11
Horizontal Cleanout Door Rockshaft Adjustment	4-13
Auger System	
Vertical Auger	4-15
Vertical Auger Folding Linkage Adjustment.....	4-16
Vertical Auger Timing	4-17
Horizontal Auger	4-18
5-Pin Driver Replacement.....	4-19
Belt Tightener Adjustment.....	4-24
V-Belt Alignment	4-26
Split Tapered Bushings.....	4-26
Verify Telescoping PTO Shaft Length	4-27
PTO Shaft & Clutch.....	4-29
PTO Quick Disconnect.....	4-31
Tarp Troubleshooting Inspection & Maintenance	4-32
Electrical System Schematic.....	4-33
Electrical Over Hydraulic (EOH) System Schematic - 5 Function Control Grip Option.....	4-35
5 Function Remote Option Electrical Schematic.....	4-36
Optional Electric Over Hydraulic Valve Electric Schematic 5 Spool.....	4-37
Wheels & Tires	
Wheel Nut Torque Requirements.....	4-38
Tire Pressure	4-39
Tire Warranty	4-41
Torque Chart - Hardware Grade 5.....	4-42
Torque Chart - Hardware Grade 8.....	4-43
Hydraulic Fittings - Torque and Installation	4-44

FOR SCALE INFORMATION, PLEASE REFER TO YOUR SCALE MANUAL.

FOR TRACK INFORMATION, PLEASE REFER TO YOUR TRACK MANUAL.

FOR U-HARVEST SCALE INFORMATION, PLEASE REFER TO YOUR U-HARVEST MANUAL.

FOR WATER DELIVERY SYSTEM INFORMATION, PLEASE REFER TO YOUR WATER DELIVERY SYSTEM MANUAL.

Lubrication

To keep your grain cart in top operating condition and to assure its proper performance and reliability for a long period of time, periodic inspection and lubrication is a must.

Fig. 4-1

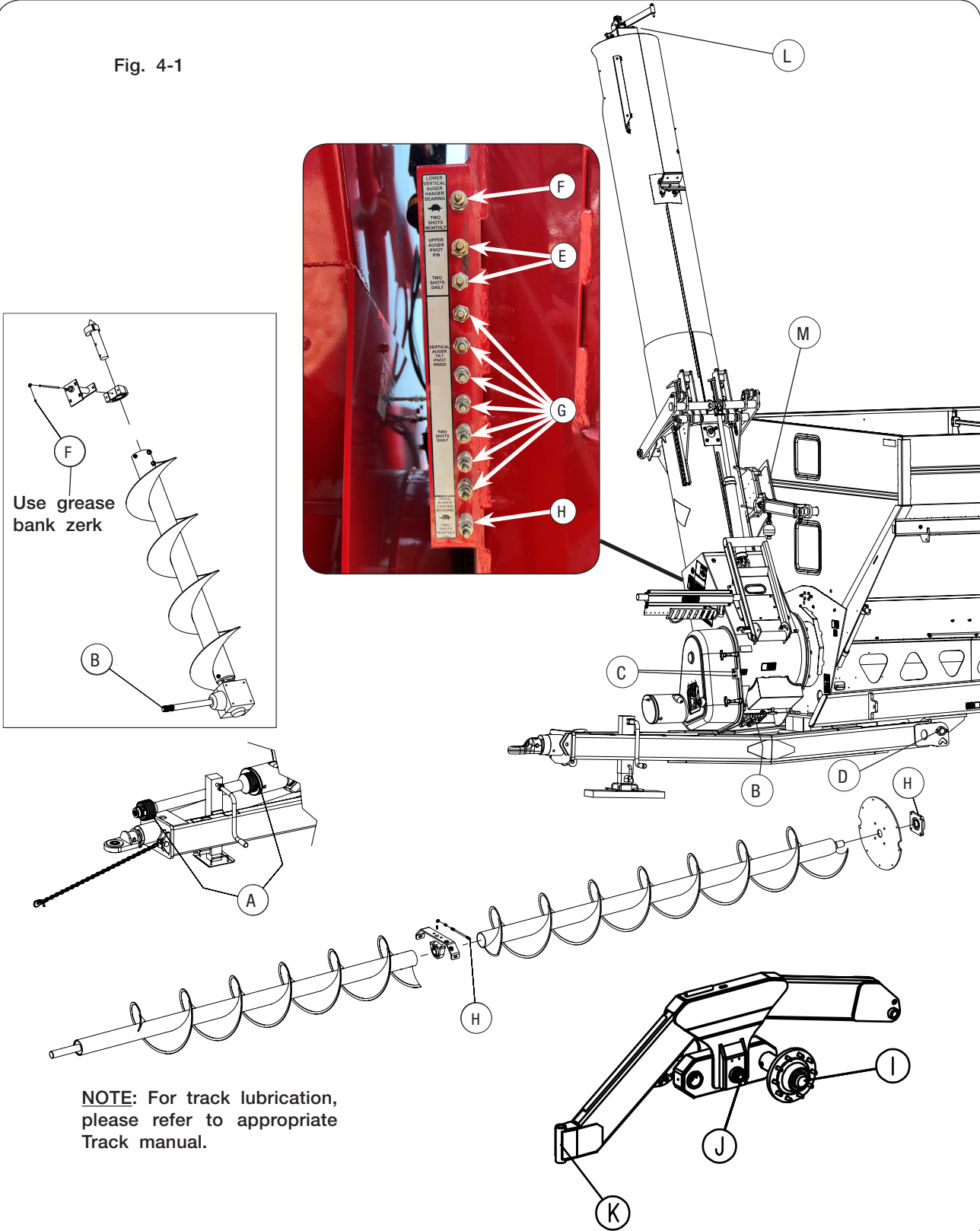

Lubrication

Fig. 4-2

LUBRICATION INSTRUCTIONS FOR DRIVE LINE

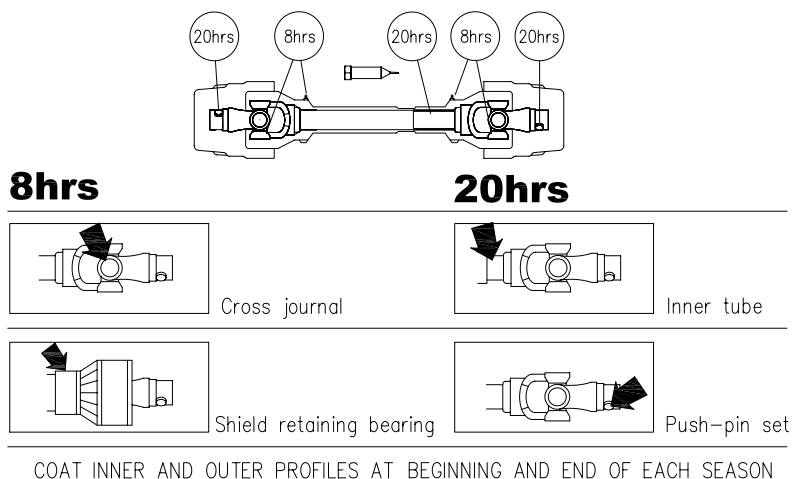

Unverferth Mfg. recommends use of NLGI #2 Extreme Pressure grease.

The lubrication locations and recommended schedule are as follows:

ITEM	DESCRIPTION	POINT	LUBRICANT	QTY.	HOURS
A	PTO Driveshaft	3	EP-2	1 Shot	See Chart Above
B	Gearbox - Check oil level every 2 weeks. Replace oil every season. Refer to Gearbox in MAINTENANCE section for instructions.	1	EP80W90	Approx 85 oz.	Once Every Season
C	Front Horizontal Auger Bearing & Gearbox Support Bearing	2	EP-2	2 Shots	Weekly
D	Tongue Bushing - 1 per side	2	EP-2	2 Shots	Daily
E	Grease Bank for Auger Pivot Pin - Vertical Upper Auger Hinge	2	EP-2	2 Shots	Daily
F*	Grease Bank for Hanger Bearing - Vertical Lower Auger *See note below.	1	EP-2	2 Shots*	Monthly
G	Grease Bank for Auger Pivot Rings - Front & Rear Auger Hinge	7	EP-2	2 Shots	Daily
H	Grease Bank for Horizontal Auger End & Center Bearings	2	EP-2	2 Shots	Monthly
I	Hubs	2 / 4	EP-2	Repack	Annually
J	Walking Beam Pivot	2	EP-2	3 Shots	Weekly
K	Walking Tandem Main Frame Pivot	2	EP-2	2 Shots	Each Season
L	Top Bearing - Vertical Upper Auger	1	EP-2	1 Shot	Each Season
M	Grease Slide Plate	1	EP-2	1 Shot	Each Season

***NOTE:** Hanger bearing contains hydraulic shut-off grease zerk (9005240) with pressure relief to prevent over-greasing that could push bearing seals out. If grease is coming out of the relief on the zerk, this is normal and the bearing contains enough grease.

Hydraulic System

Refer to parts section for hydraulic component detail listing.

When properly assembled and maintained, the hydraulic system of the grain cart requires little maintenance.

Replacing Hoses/Fittings/Cylinders:

1. Use replacement hoses, fittings, and cylinders from your Unverferth Manufacturing dealer which are rated for 3000 psi.
2. Do not use hoses, fittings and cylinders that have pipe threads.
3. Do not use Teflon tape or thread sealant on JIC or O-ring fittings. Tighten fittings according to “Torque Chart - Hydraulic Fittings” in this section.
4. When replacing hoses, always allow sufficient slack to permit hoses to move through the full range of motion of the cylinders.
5. Always purge the hydraulic system after servicing.

Purge Hydraulic System

WARNING

- **HYDRAULIC SYSTEM MUST BE PURGED OF AIR BEFORE OPERATING TO PREVENT SERIOUS INJURY OR DEATH.**
- **RELIEVE HYDRAULIC SYSTEM OF ALL PRESSURE BEFORE ADJUSTING OR SERVICING. SEE THE HYDRAULIC POWER UNIT OPERATOR’S MANUAL FOR PROPER PROCEDURES.**
- **HIGH-PRESSURE FLUIDS CAN PENETRATE THE SKIN AND CAUSE SERIOUS INJURY OR DEATH. USE CARDBOARD OR WOOD TO DETECT LEAKS IN THE HYDRAULIC SYSTEM. SEEK MEDICAL TREATMENT IMMEDIATELY IF INJURED BY HIGH-PRESSURE FLUIDS.**
- **KEEP CLEAR OF PINCH POINT AREAS.**



Purge air from system as follows:

- A. Disconnect the rod end of all cylinders in a circuit and block up cylinders so the rod can completely extend and retract without contacting any other component.
- B. Pressurize the system and maintain system at full pressure for at least 5 seconds after cylinder rods stop moving. Check that all cylinders have fully extended or retracted.
- C. Check oil reservoir in hydraulic power source and refill as needed.
- D. Pressurize system again to reverse the motion of step B. Maintain pressure on system for at least 5 seconds after cylinder rods stop moving. Check that cylinders have fully extended or retracted.
- E. Check for hydraulic leaks using cardboard or wood. Tighten connections according to directions in Torque Chart.
- F. Repeat steps B, C, D, and E 3-4 times.
- G. Depressurize hydraulic system and connect cylinder rod clevises to their mating lugs.

IMPORTANT

- *Machine damage will occur if the cylinder is incorrectly installed.*

Check for and correct any leaks. Make sure hoses are not kinked, stretched, or twisted. Secure hoses to prevent cuts or chafing during operation.

Hydraulic System (continued)

Relieving Hydraulic Pressure

To relieve hydraulic pressure in the system, be sure hydraulic motor is disengaged and/or hydraulic cylinder is not exerting force on the system. Next, consult tractor operators manual for procedure to relieve pressure.

Purging Procedure For EOH System

WARNING

- RELIEVE THE HYDRAULIC SYSTEM OF ALL PRESSURE BEFORE ADJUSTING OR SERVICING. SEE THE HYDRAULIC POWER UNIT OPERATOR'S MANUAL FOR PROPER PROCEDURES.
- HIGH-PRESSURE FLUIDS CAN PENETRATE THE SKIN AND CAUSE SERIOUS INJURY OR DEATH. USE CARDBOARD OR WOOD TO DETECT LEAKS IN THE HYDRAULIC SYSTEM. SEEK MEDICAL TREATMENT IMMEDIATELY IF INJURED BY HIGH-PRESSURE FLUIDS.
- EYE PROTECTION AND OTHER APPROPRIATE PERSONAL PROTECTIVE EQUIPMENT MUST BE WORN WHILE SERVICING IMPLEMENT.

NOTE: Make sure hoses are not kinked, stretched, or twisted. Secure hoses to prevent cuts or chafing during operation.

1. Open flow door and hold SCV for 5 seconds. Close flow door and hold SCV for 5 seconds. Repeat at least 3 times until movement is smooth and even.
2. Pivot auger all the way down and hold SCV for 5 seconds. Raise auger all the way up and hold SCV for 5 seconds. Repeat at least 3 times until movement is smooth and even.
3. Rotate spout all the way forward and hold SCV for 5 seconds. Rotate spout all the way rearward and hold SCV for 5 seconds. Repeat at least 3 times until movement is smooth and even.
4. Tilt spout all the way out and hold SCV for 5 seconds. Tilt spout all the way in and hold SCV for 5 seconds. Repeat at least 3 times until movement is smooth and even.
5. Fold auger to transport position and hold SCV for 5 seconds. Unfold auger all the way and hold SCV for 5 seconds. Repeat at least 3 times until movement is smooth and even.

Walking Tandem Option

WARNING

- **FALLING OBJECTS CAN CAUSE SERIOUS INJURY OR DEATH. DO NOT WORK UNDER THE MACHINE AT ANY TIME WHILE BEING HOISTED. BE SURE ALL SAFE LIFTING DEVICES AND SUPPORTS ARE RATED FOR THE LOADS BEING HOISTED. THESE ASSEMBLY INSTRUCTIONS WILL REQUIRE SAFE LIFTING DEVICES UP TO 10,000 LBS. SPECIFIC LOAD RATINGS FOR INDIVIDUAL LOADS WILL BE GIVEN AT THE APPROPRIATE TIME IN THE INSTRUCTIONS.**
- **EYE PROTECTION AND OTHER APPROPRIATE PERSONAL PROTECTIVE EQUIPMENT MUST BE WORN WHILE SERVICING IMPLEMENT.**
- **KEEP HANDS CLEAR OF PINCH POINT AREAS.**

CAUTION

- **WHEN CHANGING TIRES OR ROW SPACING, IT IS IMPORTANT TO FOLLOW THE STEPS BELOW TO MAINTAIN STABILITY OF THE CART. CHANGE ONE SIDE AT A TIME.**
- **IMPROPERLY TORQUED WHEEL NUTS/BOLTS CAN CAUSE A LOSS OF IMPLEMENT CONTROL AND MACHINE DAMAGE. TORQUE WHEEL NUTS/BOLTS TO VALUES IN TABLE. CHECK TORQUE BEFORE USE, AFTER ONE HOUR OF UNLOADED USE OR AFTER FIRST LOAD, AND EACH LOAD UNTIL WHEEL NUTS/BOLTS MAINTAIN TORQUE VALUE. CHECK TORQUE EVERY 10 HOURS OF USE THERE-AFTER. AFTER EACH WHEEL REMOVAL START TORQUE PROCESS FROM BEGINNING. WARRANTY DOES NOT COVER FAILURES CAUSED BY IMPROPERLY TORQUED WHEEL NUTS/BOLTS.**

Inner Dual Wheel Access

Use the following procedure to service the inside dual tires.

1. Hitch cart to tractor and chock tractor wheels.
2. Using a safe lifting device rated for 10,000 lbs., raise one side of cart by lifting under the outer end of rear support tube.
3. Using a safe lifting device rated for 4,000 lbs., support the rear portion of the walking tandem assembly.
4. Remove rear retaining hardware, then pivot walking tandem assembly outward to access inner wheel.



Walking Tandem Option (continued)

Inner Dual Wheel Access (continued)

NOTE: Walking tandem assembly must be suitably supported during and after pivoting.

- Reverse steps 2 through 4 to reattach walking tandem assembly before attempting to service other side of cart.

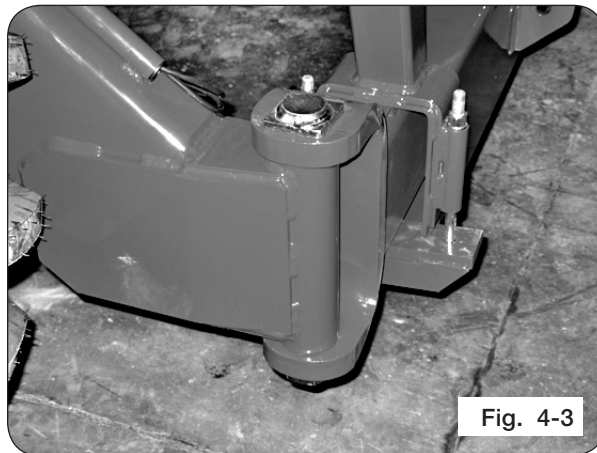

Row Spacing Adjustment

The factory row spacing is 30". The following procedure is for achieving 36" row spacing. This procedure involves switching the inner and outer tire positions and moving the entire assembly out approximately 9" to change from a 30" to 36" row spacing:

- Hitch cart to tractor and chock tractor wheels.
- Using a safe lifting device rated for 10,000 lbs., raise one side of cart by lifting under the outer end of rear support tube. Using a safe lifting device rated for 4,000 lbs., support the rear portion of the walking tandem assembly and raise one side of the cart.
- Remove the rear retaining hardware. Then pivot walking tandem assembly outward to access inner wheel.



NOTE: Walking tandem assembly must be suitably supported during and after pivoting.

- Remove the 1 1/8" bolt and loosen front axle beam clamp bolts and extend front pivot beam out approximately 9 inches.
- Retain same original tread direction and reinstall the previous "Outer" side of tire to the inside hub and the previous "Inner" side of tire to the outer hub.
- Pivot walking tandem assembly in towards the cart and align bracket mounting holes with cross beam mounting plate outer holes.
- Reinstall 1 1/8" bolt and torque 640 ft.-lbs. Reinstall rear retaining hardware, tighten front beam clamp bolts and torque 260 ft.-lbs. Lower cart to the ground.

Use same procedures for the opposite side of cart.

(Continued on next page)

Walking Tandem Option (continued)

Use the following procedures for extending the entire assembly only.

1. Using a safe lifting device rated for 10,000 lbs., raise one side of cart by lifting under the outer end of rear support tube. Using a safe lifting device rated for 4,000 lbs., to support weight of tires and walking beam assembly.
2. Loosen the front axle clamp hardware. Remove the 1 1/8" bolt located toward the center of the front axle. This bolt determines the row spacing as well as the extra set of holes on the rear cross axle. Remove the rear retaining hardware.
3. Slide axle extension on front of cart equally inward or outward as needed and reinstall bolts. Rear portion of the walking tandem assembly will also need adjusted outward to either the middle or outside set of holes on the rear cross tube mount plate depending on the location of the front axle extension. Lower to the ground.

Use same procedures to opposite side of cart.

Seasonal Storage

Always open flow door, horizontal and vertical auger cleanout doors to remove any remaining grain and to allow moisture to dry.

Wash machine inside and out before storing to remove dirt and debris that can draw and collect moisture. When using pressure washers maintain an adequate distance so not to force water into bearings.

Reattach PTO brackets (291974G or 291974R) to the inside right-hand side of the tongue and place PTO assembly on brackets.

Lubricate machine at all points outlined.

Repaint all areas where paint has been removed to keep rust from developing. Rust will affect grain flow.

Coat exposed cylinder piston rods with rust preventative material if applicable.

Inspect machine for parts that may need to be replaced so they may be ordered in the off season.

If unit is equipped with a scale indicator or electric hydraulic controls store these indoors in a dry location.

Close the tarp to keep debris out of the hopper.



Gearbox Sight Glass

When checking the oil level of the gearbox, the vertical auger should be tilted all the way down.

For adequate lubrication the oil should be visible in the sight glass. Fill with oil to the sight glass only. (FIG. 4-6)

Maximum gearbox life:

Check oil level every 2 weeks.

Replace oil every season with approximately 85 oz 80W90 EP lubricant.

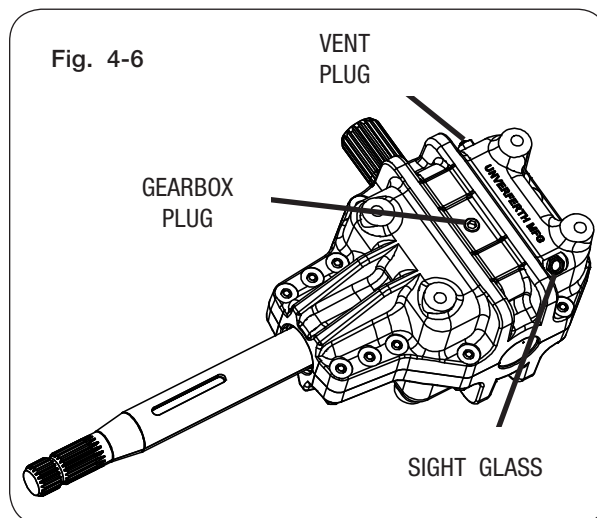

Driveline Removal

⚠ DANGER

- ENTANGLEMENT WITH THE DRIVELINE WILL CAUSE SERIOUS INJURY OR DEATH. KEEP ALL GUARDS AND SHIELDS IN GOOD CONDITION AND PROPERLY INSTALLED AT ALL TIMES. AVOID PERSONAL ATTIRE SUCH AS LOOSE FITTING CLOTHING, SHOE STRINGS, DRAWSTRINGS, PANTS CUFFS, LONG HAIR, ETC. THAT CAN BECOME EN-TANGLED IN A ROTATING DRIVELINE.

⚠ WARNING

- MOVING OR ROTATING COMPONENTS CAN CAUSE SERIOUS INJURY OR DEATH. ENSURE SERVICE COVERS, CHAIN/BELT COVERS AND CLEAN-OUT DOOR ARE IN PLACE AND SECURELY FASTENED BEFORE OPERATING UNIT.

Gearbox shaft guard has access doors for installing and removing of driveline.

Clamping Cone Assembly

Use a hammer and punch and moderately hit the end of clamping cone, as shown. Back off the clamping cone 1/2 turn. Continue alternating punch and unscrewing clamping cone until clamping cone can be removed by hand. (FIG. 4-7)

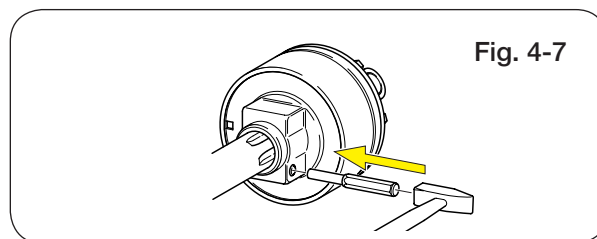

Auger Driveline Bearings

IMPORTANT

- Periodically check set screws in all bearings at either end of the driveline for tightness. (FIG. 4-8 & 4-9)

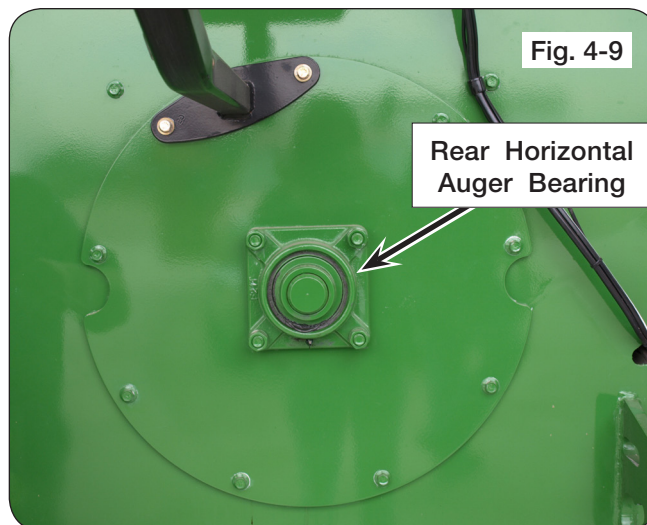
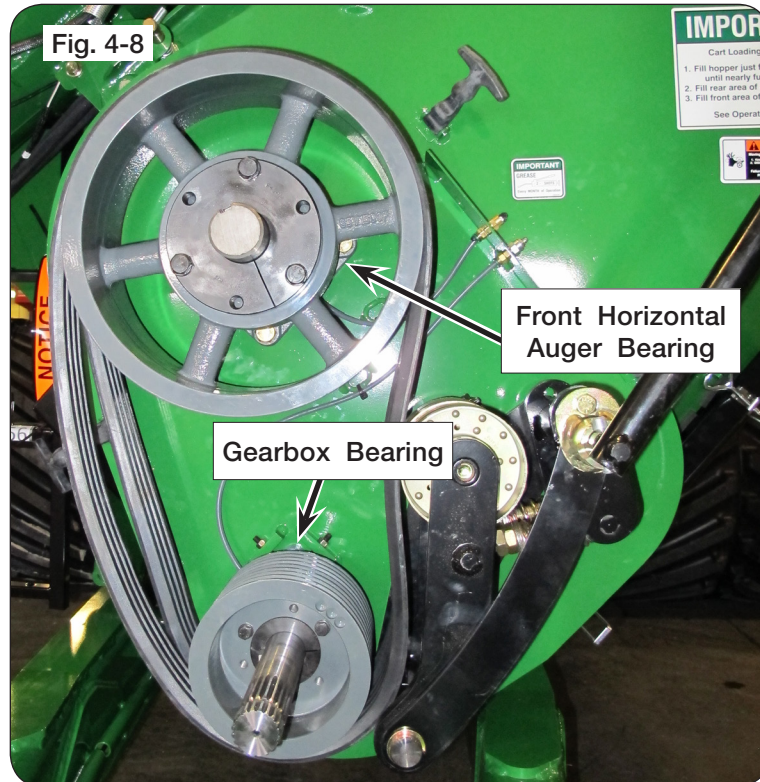

Baffle Adjustment

WARNING

- **TO PREVENT PERSONAL INJURY OR DEATH, ALWAYS ENSURE THAT THERE ARE PEOPLE WHO REMAIN OUTSIDE THE CART TO ASSIST THE PERSON WORKING INSIDE THE CART, AND THAT ALL SAFE WORKPLACE PRACTICES ARE FOLLOWED. THERE ARE RESTRICTED MOBILITY AND LIMITED EXIT PATHS WHEN WORKING INSIDE THE CART.**
- **NEVER ENTER CART WITH AUGER OR TRACTOR RUNNING. SERIOUS OR FATAL INJURY CAN OCCUR DUE TO ENTANGLEMENT WITH ROTATING COMPONENTS. ALWAYS STOP ENGINE AND REMOVE KEY BEFORE ENTERING CART.**

Refer to the following reasons for baffle adjustment:

NOTE: To unload the cart evenly from front to back the openings should increase in height from back to front.

1. If higher flow is desired and torque is not the limiting factor, raise each baffle to an incremental amount and rerun.
2. If more material remains at the back of the cart towards the end of the unloading cycle, the back baffles should be adjusted upward in incremental amounts and rerun.
3. If more material remains at the front of the cart towards the end of the unloading cycle, the back baffles should be adjusted downward in incremental amounts and rerun.
4. If the cart requires more torque than what is available at times during the unloading cycle, then all baffles should be adjusted downward in incremental amounts.

(Continued on next page)

Baffle Adjustment (continued)

The horizontal auger baffles are factory-set at the lowest position. This position results in the lowest power requirements and longest flighting life. Once grain has been run through the unit, adjustments can be made to achieve the ideal unloading performance.

Before making any baffle adjustments, close horizontal auger flow door. Securely block the grain cart, set the tractor parking brake, turn off tractor engine and remove ignition key.

If a higher flow is desired and torque is not a factor, loosen the (2) flange nuts on each baffle, see figure 4-15. Use the lift handle to raise each baffle to the desired position, retighten both flange nuts, see figures 4-15 & 4-16.

NOTE: DO NOT REMOVE ANY SCREEN PANELS. The flange nuts are best accessed using an extended socket wrench and 9/16" socket through the screen panel openings.

NOTE: Screen removed in figure 4-16 for illustration only.

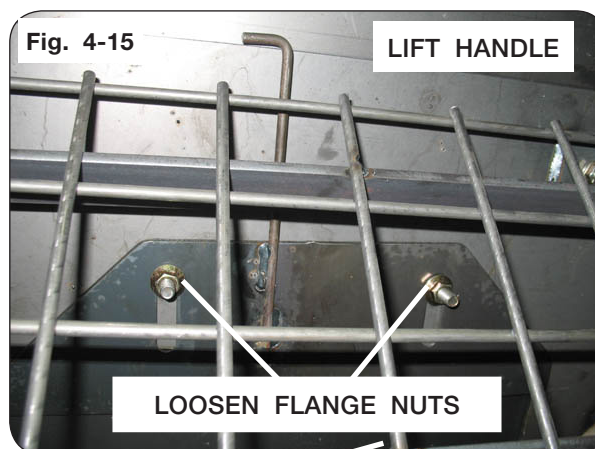
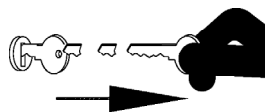

Horizontal Cleanout Door Rockshaft Adjustment

⚠ WARNING

- MOVING OR ROTATING COMPONENTS CAN CAUSE SERIOUS INJURY OR DEATH. ENSURE SERVICE COVERS, CHAIN/BELT COVERS AND CLEANOUT DOORS ARE IN PLACE AND SECURELY FASTENED BEFORE OPERATING UNIT.
- KEEP HANDS CLEAR OF PINCH POINT AREAS.
- TIPPING OR MOVEMENT OF THE MACHINE CAN CAUSE SERIOUS INJURY OR DEATH. BE SURE THE MACHINE IS SECURELY BLOCKED.
- EYE PROTECTION AND OTHER APPROPRIATE PERSONAL PROTECTIVE EQUIPMENT MUST BE WORN WHILE SERVICING THE IMPLEMENT.

1. Park the unit on a firm, level surface. Block the wheels/tracks to keep the machine from moving. Set the tractor parking brake, turn off tractor engine, remove ignition key, and disconnect PTO shaft.
2. Loosen all the hardware in the slotted brackets connecting the cleanout door rockshaft to the grain cart tube. (Fig. 4-12)
3. Starting at the front of the cart, using a jack, push the rockshaft up and toward the runner tube. (Fig. 4-12)

NOTE: Ideal distance between the runner tube and rockshaft is 3 1/4”.

4. When the rockshaft is in position, torque the hardware previously loosened to 28 ft.-lbs.
5. Continue repositioning the rockshaft moving toward the back of the cart.

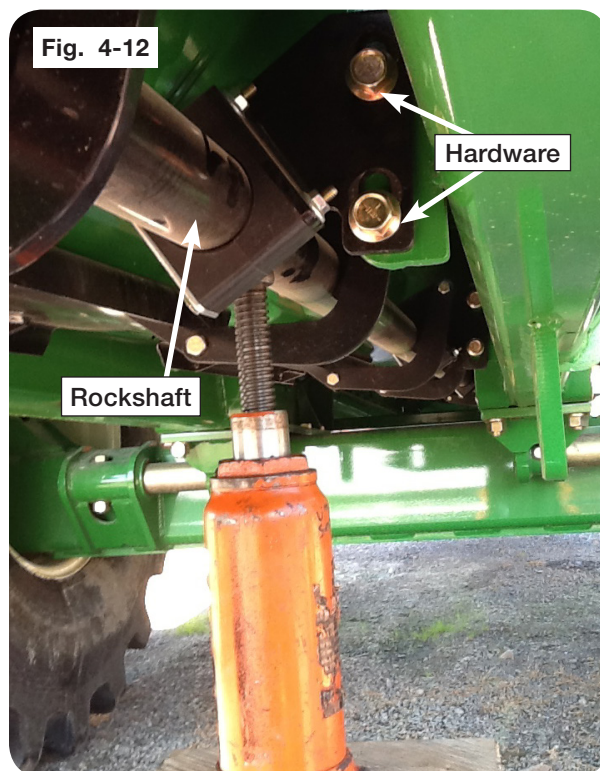

Horizontal Cleanout Door Rockshaft Adjustment (continued)

6. Rotate the tensioner handle counter-clockwise to close the doors allowing the plate to fit and seal into the belly pan opening. (Fig. 4-13 & 4-14)
7. Open the doors and torque plate hardware to 17 ft.-lbs. (Fig. 4-14)
8. Close the doors and ensure all doors seal. (Fig. 4-14)
9. Insert lynch pin into rockshaft and return handle to storage location.

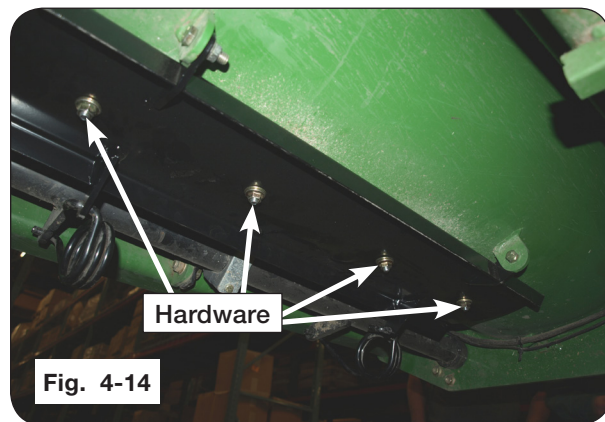
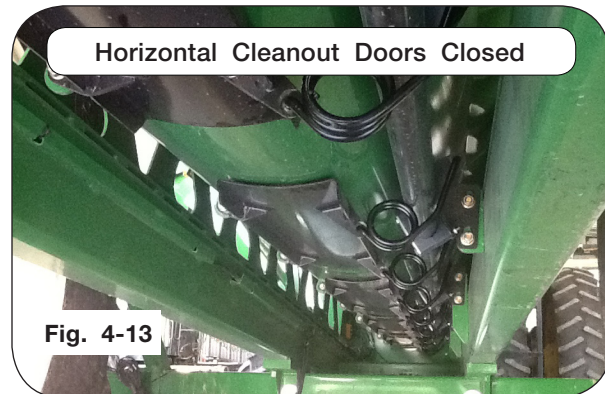

Auger System

Vertical Auger

Annually check all bolts, nuts, and set screws. Perform lubrication as specified.

Before servicing the vertical auger, park the unit on a firm, level surface. Block the wheels/tracks to keep the machine from moving. Raise vertical auger to discharge position and close horizontal auger flow door. Set the tractor parking brake, turn off tractor engine, remove ignition key, and disconnect PTO shaft and hydraulic lines from tractor.

NOTE: The lower auger position is indexed from the drive dog / tube flange hinge surface as shown. (Fig. 4-15)

NOTE: Hanger bearing contains zerk (9005240) with pressure relief to prevent over-greasing that could push bearing seals out. If grease comes out of the relief on the zerk, this is normal and the bearing has enough grease.

(Continued on the next page.)

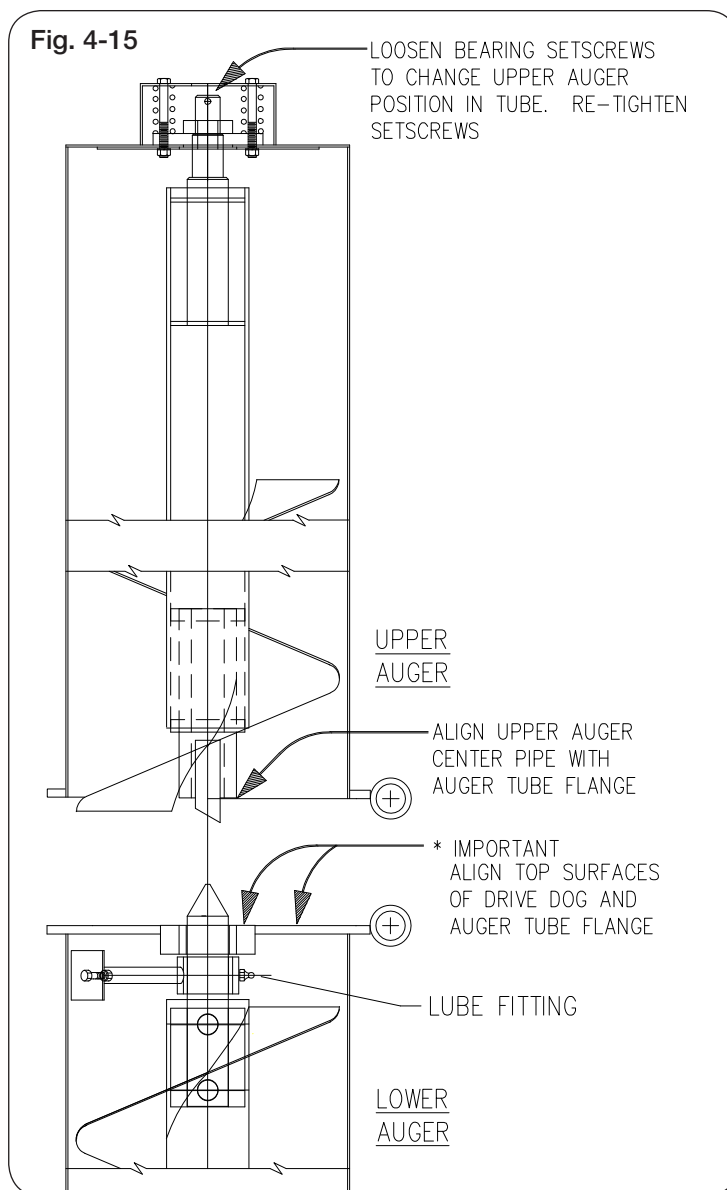

Auger System (continued)

Vertical Auger Folding Linkage Adjustment

NOTE: To fold auger from operating position to transport position, refer to “Electric Over Hydraulic Operation (Optional)” in the OPERATION section.

1. Before adjusting the vertical auger folding linkage, park the unit on a firm, level surface. Block the wheels/tracks to keep the machine from moving. Set the tractor parking brake, turn off tractor engine, remove ignition key, and disconnect PTO shaft and hydraulic lines from tractor.



NOTE: The starting distance for the folding linkage pin center-to-center is 13 3/4". (FIG. 4-16)

2. Adjust the folding linkage on the FRONT of the auger until the center-of-pin to center-of-pin measurement on the folding linkage attaching pins is 13 3/4". (FIG. 4-16)
3. Repeat procedure for the folding linkage on the BACK of the auger.
4. Choose an area free from obstructions and unfold auger to operating position. Allow sufficient time for the cylinder to fully engage the two augers and over-center latch to fully engage.
5. Verify the upper auger picture frame is flush against the lower auger picture frame.

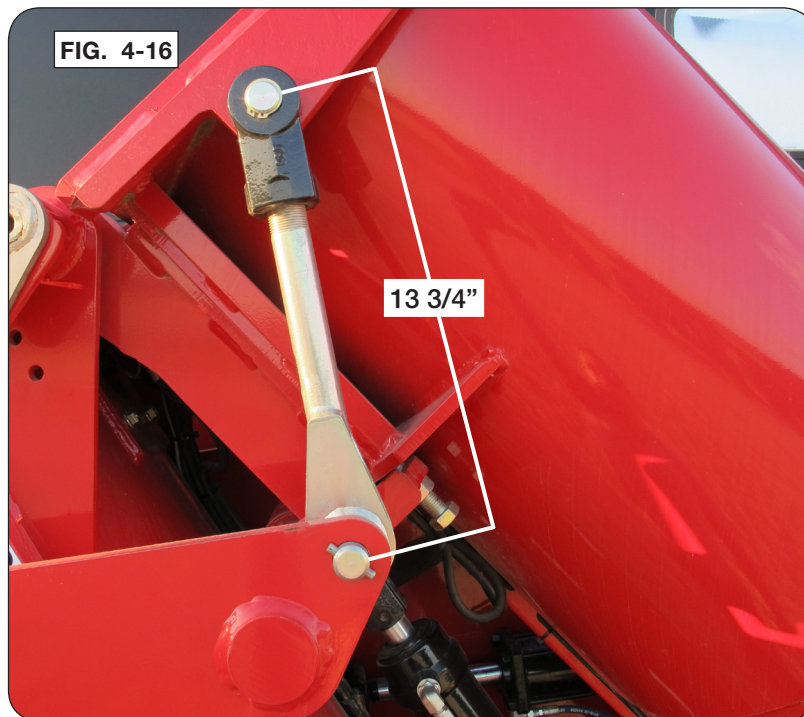

Auger System (continued)

Vertical Auger Timing

1. For the lower vertical auger, use the finishing edge of the flighting as a 12 o'clock reference. Position the drive dog so the driving edge is at the 11 o'clock position. (FIG. 4-17)

NOTE: Looking down at the lower flighting (FIG. 4-17) the auger rotation will be counter-clockwise. When looking up at the upper flighting (FIG. 4-18) the auger rotation will be clockwise.

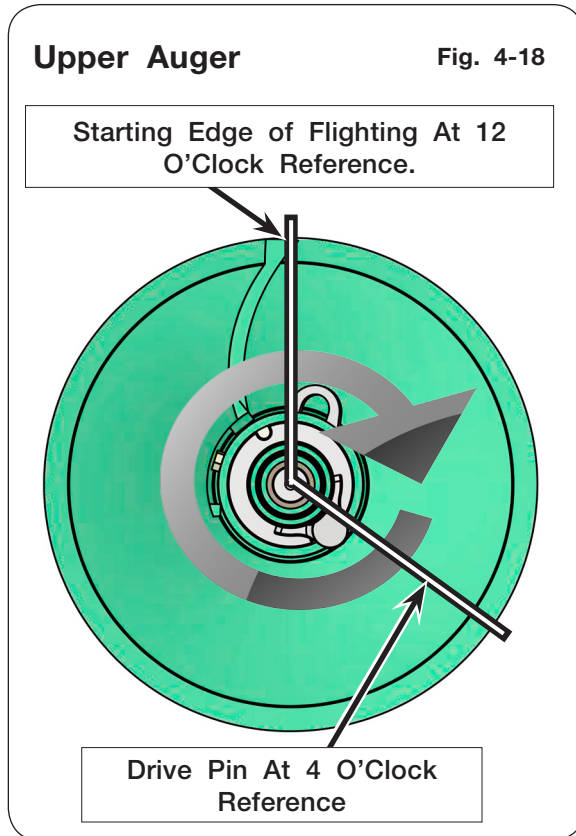
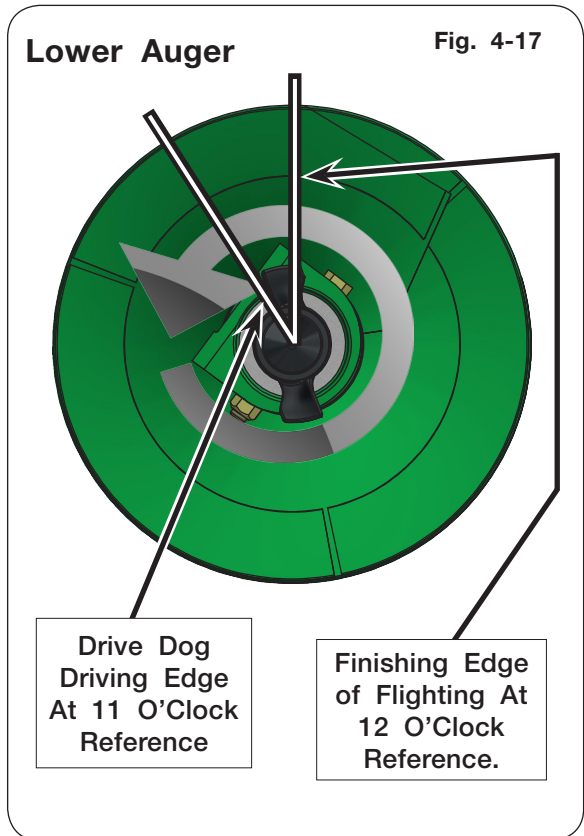

2. For the upper auger, use the starting edge of the flighting as a 12 o'clock reference. Position the driven edge of the drive pin at the 4 o'clock position. (FIG. 4-18)
3. When engaged, the upper flighting should follow the lower flighting. (FIG. 4-19)

NOTE: Upper flighting should trail the lower flighting from minimum of 10 degrees to a maximum of 90 degrees.

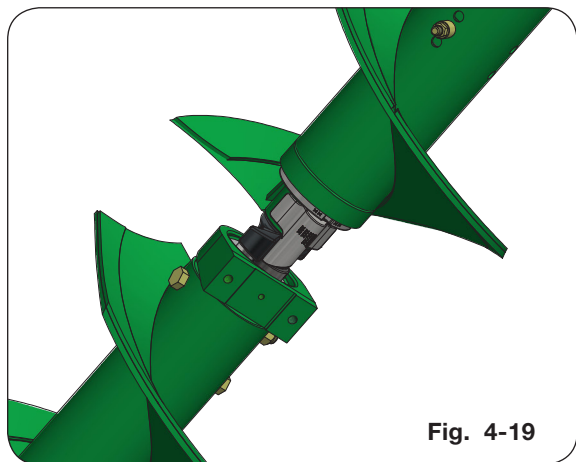

Auger System (continued)

Horizontal Auger

Annually check all bolts, nuts, and set screws. Perform lubrication as specified.

NOTE: Shims are available from your Brent dealer to achieve 10 1/8" measurement.

NOTE: With new flighting the outside diameter is about 3/4" from the bottom belly pan. Always set bearing height using the flighting centerline measurement. See FIG. 4-20.

To adjust the bearing height down, shim with washers between the bearing and the hanger bracket. To adjust the bearing height up, shim with washers between the bearing bracket and the sides of the cart. When adjusting the height up, washers will need to be placed with one on each side so the bearing stays centered.

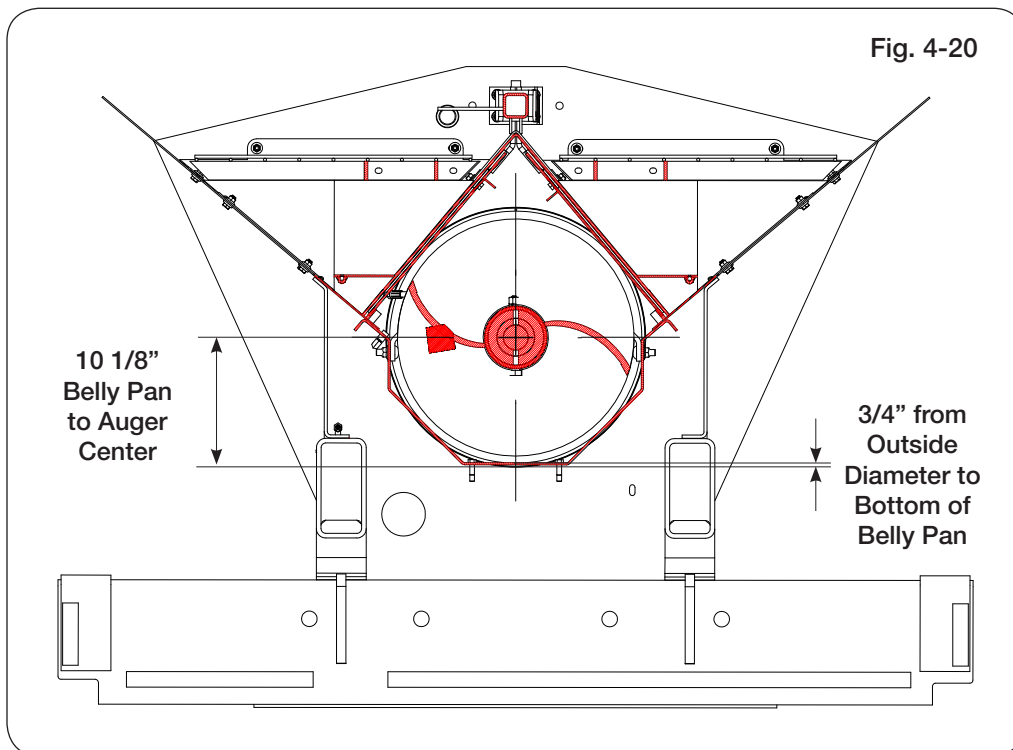

5-Pin Driver Replacement

WARNING

- TO PREVENT PERSONAL INJURY OR DEATH, ALWAYS ENSURE THAT THERE ARE PEOPLE WHO REMAIN OUTSIDE THE CART TO ASSIST THE PERSON WORKING INSIDE, AND THAT ALL SAFE WORKPLACE PRACTICES ARE FOLLOWED. THERE ARE RESTRICTED MOBILITY AND LIMITED EXIT PATHS WHEN WORKING INSIDE THE IMPLEMENT.
- NEVER ENTER CART WITH AUGER OR TRACTOR RUNNING. SERIOUS OR FATAL INJURY CAN OCCUR DUE TO ENTANGLEMENT WITH ROTATING COMPONENTS. ALWAYS STOP ENGINE AND REMOVE KEY BEFORE ENTERING CART.
- EYE PROTECTION AND OTHER APPROPRIATE PERSONAL PROTECTIVE EQUIPMENT MUST BE WORN WHILE SERVICING IMPLEMENT.
- KEEP HANDS CLEAR OF PINCH POINT AREAS.
- FALLING OBJECTS CAN CAUSE SERIOUS INJURY OR DEATH. DO NOT WORK UNDER THE MACHINE AT ANY TIME WHILE BEING HOISTED. BE SURE ALL SAFE LIFTING DEVICES AND SUPPORTS ARE RATED FOR THE LOADS BEING HOISTED. THESE ASSEMBLY INSTRUCTIONS WILL REQUIRE SAFE LIFTING DEVICES UP TO 1,000 LBS. SPECIFIC LOAD RATINGS FOR INDIVIDUAL LOADS WILL BE GIVEN AT THE APPROPRIATE TIME IN THE INSTRUCTIONS.

NOTE: Open the flow gates all the way.

1. Park the unit on a firm, level surface. Block the wheels to keep the machine from moving. Set the vehicle parking brake, shut off the engine and remove the ignition key and disconnect the PTO shaft or hydraulic drivelines from the tractor.

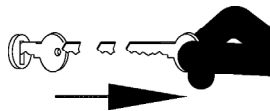

2. Remove the bolts in both middle grates inside the cart. Remove the grates. (Figure 4-21)

NOTE: Retain all hardware for reassembly.

3. Disconnect grease line. (Figure 4-22)
4. Remove the hanger bearing bolts on each side of the auger.
5. Remove capscrews and lock washers holding bearing onto the hanger bearing plate.

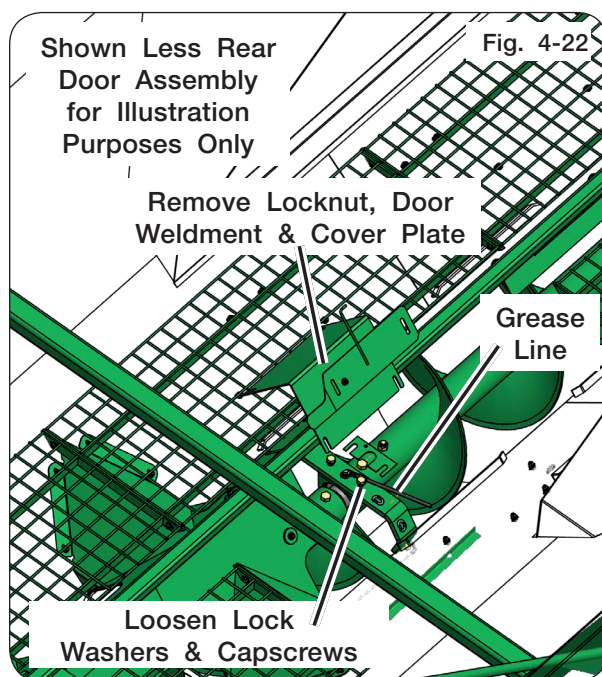
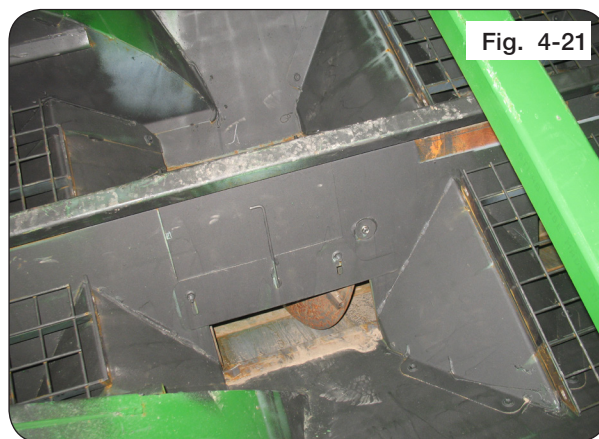

5-Pin Driver Replacement (continued)

6. Remove the hanger bearing bracket to allow access to work on the bearing and shaft. Remove two center tube connecting capscrews in the horizontal auger. (Figure 4-23)

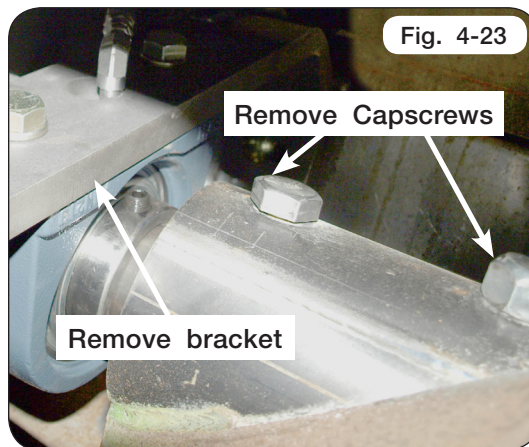

7. Remove the SMV bracket located on the rear auger cover. (Figure 4-24)

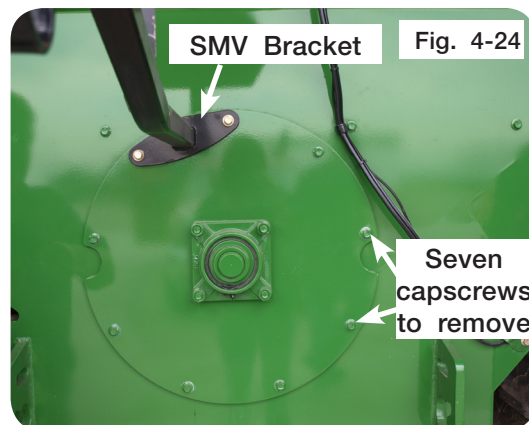

8. Remove the capscrews from the auger cover. (Figure 4-24)

9. Pry the auger from the auger tube. (Figure 4-25)

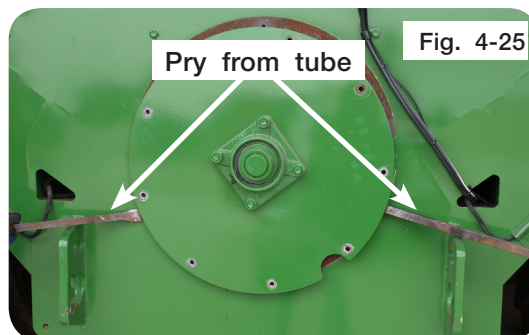

10. Using a safe lifting device rated for a minimum 1,000 lbs., pull the rear auger out 3 feet using a strap. (Figure 4-26)

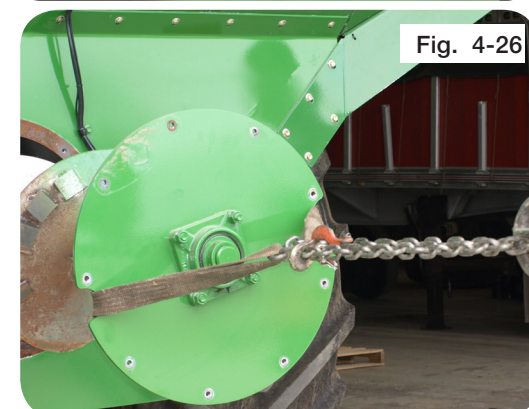

5-Pin Driver Replacement (continued)

11. Remove the original 5-pin driver, bearing and the bushing insert. (Figure 4-27 & Figure 4-28)
12. Discard 5-pin driver.



Fig. 4-27

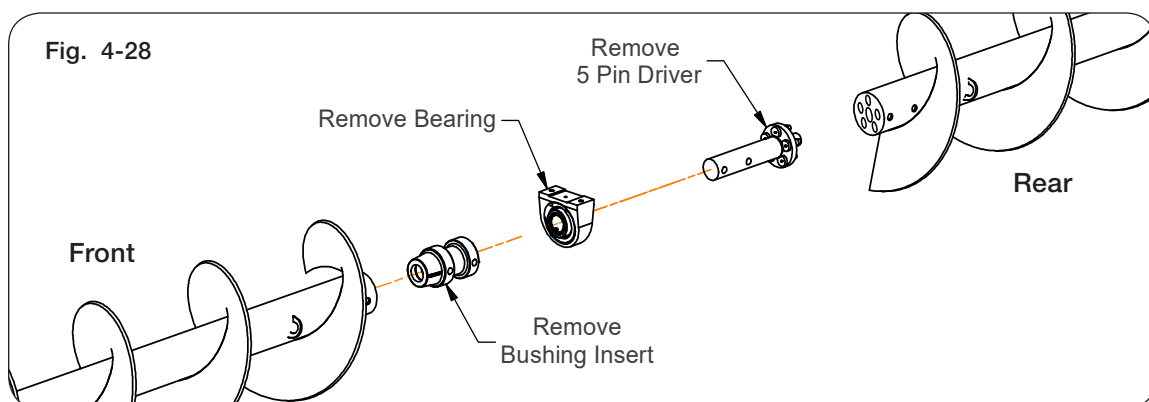

Fig. 4-28

13. Substantially coat bushing insert with anti-seize.
14. Slide bushing insert into front auger and ensure tube holes are aligned. (Figure 4-28 & Figure 4-29)

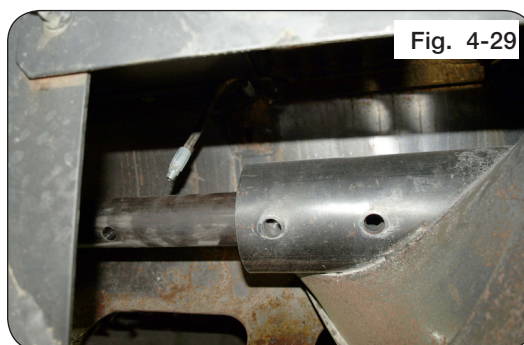

Fig. 4-29

NOTE: Make sure the set screws on bearing are towards the front of the cart. (Figure 4-30)

15. Slide bearing onto 5-pin driver. (Figure 4-30)
16. Insert new 5-pin driver into front auger and ensure tube holes are aligned.
17. Install front capscrews, spacer bushings and locknuts 180 degrees from each other and assemble spacer bushings on threaded side of capscrews. Hand tighten hardware. (Figure 4-30)

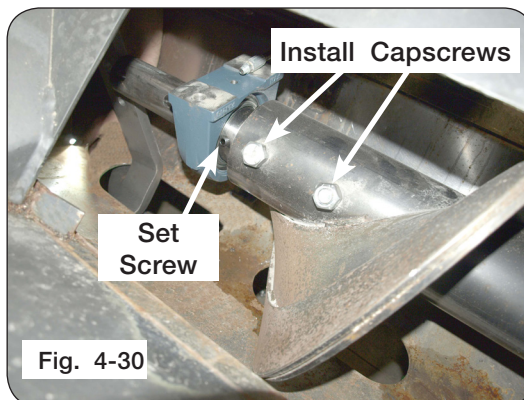
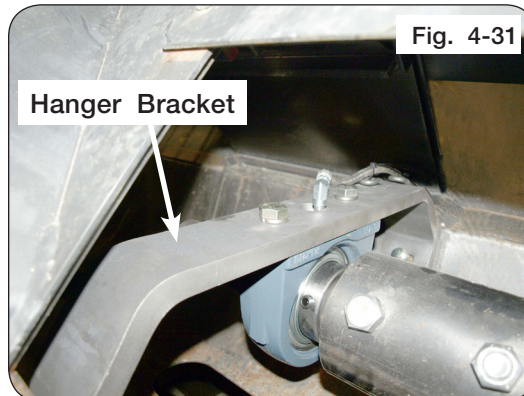

Fig. 4-30

5-Pin Driver Replacement (continued)

18. Install hanger bracket. Leave the capscrews loose attaching hanger bracket to the cart. Attach hanger bracket to the bearing. (Figure 4-31)
19. Reattach grease line components. (Figure 4-31)



NOTE: Rear auger flighting should lead the front auger flighting.

20. Slide the rear auger forward. Align the pins and holes with the rear auger pipe. (Figure 4-32)

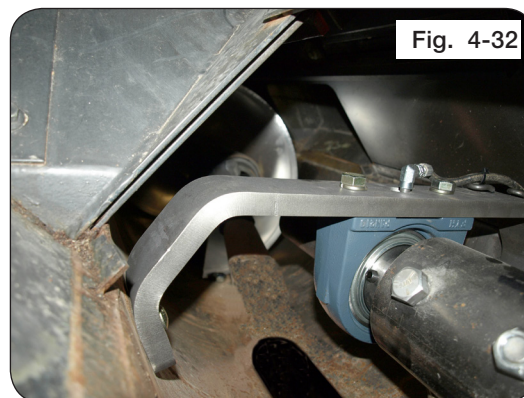

21. Extend a string tightly from front to rear to check horizontal auger alignment. Measure the string to the auger tube either in front or behind the hanger bearing. If this dimension is 1/8" greater than the measurement taken in the front and rear, shims (8GA - 286419B or 12GA - 286424B) are required on top of the center hanger bearing. Ideally the center measurement should be equal to or 1/8" lower than the measurements on the ends of the augers. (Figure 4-33)

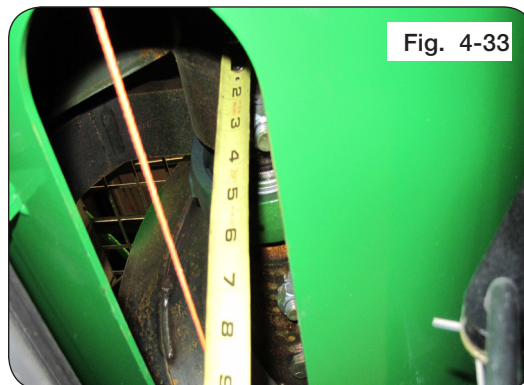

NOTE: The shims are 1/8" thick each. Add as needed. See "Auger System - Horizontal Auger" in MAINTENANCE section for more details.

22. Torque hanger bracket capscrews to 130 ft.-lbs. See Figure 4-31.
23. Torque auger capscrews to 200 ft.-lbs. (Figure 4-34)

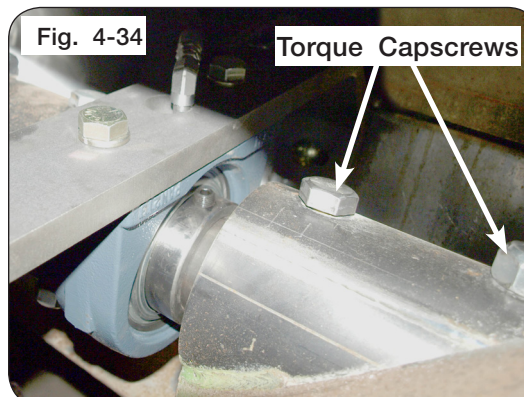

5-Pin Driver Replacement (continued)

24. Torque hardware for the rear auger cover and SMV bracket back onto the cart. (Figure 4-35)
25. Reinstall ALL the grates.

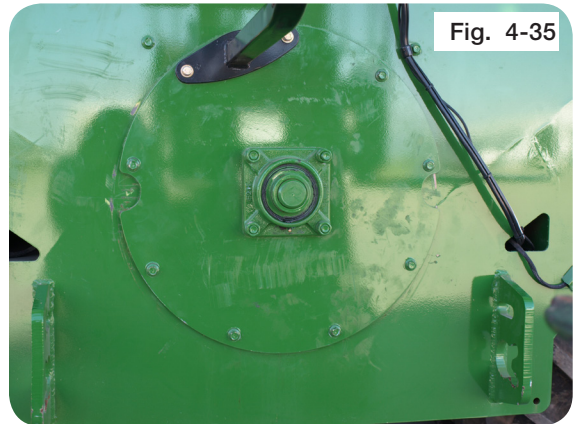

Belt Tightener Adjustment

IMPORTANT

- Do not use belt dressing.
- Keep grease and oil off of belt and pulleys.

NOTE: Pulleys do not need to be removed to remove/replace belt.

Due to prolonged use, belt wear may be evident causing slack. To correct this, follow these steps.

1. Park the unit on a firm, level surface. Block the wheels on the machine to keep it from moving. Set the vehicle parking brake, shut off the engine and remove the ignition key from the towing vehicle.



WARNING

- MOVING OR ROTATING COMPONENTS CAN CAUSE SERIOUS INJURY OR DEATH. ALWAYS DISCONNECT POWER SOURCE BEFORE SERVICING. ENSURE SERVICE COVERS, CHAIN/BELT COVERS AND CLEAN-OUT DOOR(S) ARE IN PLACE AND SECURELY FASTENED BEFORE OPERATING UNIT.
2. Remove PTO assembly from Gearbox input shaft.
 3. Detension the belt as outlined in OPERATION section. Remove belt tensioner handle.
 4. Remove cover, disengage belt tensioner handle and inspect belts for misalignment, loose parts and cracks. Replace if necessary with a matched set. See Fig. 4-38.



Belt Tightener Adjustment (continued)

5. Belt tension is adjusted with hex nuts below the spring. All belt tension **MUST** be released from linkage. Loosen outer hex nut and adjust inner nut to establish a $3 \frac{1}{16}$ " pre-load dimension between the heavy washers. Tighten the outer hex nut against inner nut to lock position. (Fig. 4-39)
6. Check the lower belt pulley to ensure belt is aligned in their grooves. Using the belt tensioner handle, engage the roller/idler linkage against the belt and over-center stop. The compressed spring should now be approximately $1 \frac{3}{4}$ " between the washers and generating a force of approximately 480 lbs. against the belt. (Fig. 4-40)
7. Release and tighten belt multiple times to confirm positions and final adjustments. See Fig. 4-40 and Fig. 4-41.
8. Tighten belt to retain them into the lower pulley for cover guard assembly. Reinstall the cover guard and the PTO shaft to the gearbox input shaft. Clear work area and test-run drivetrain for 3 minutes at no greater than 1000 RPM.

WARNING

- **MOVING OR ROTATING COMPONENTS CAN CAUSE SERIOUS INJURY OR DEATH ENSURE SERVICE COVERS, CHAIN/BELT COVERS AND CLEAN-OUT DOOR ARE IN PLACE AND SECURELY FASTENED BEFORE OPERATING UNIT.**

9. Disengage PTO, turn off towing vehicle and remove the ignition key. Through the cover access door, check the compressed spring length is approximately $1 \frac{3}{4}$ " between the washers and check each belt for uniform tension. If more adjustment is needed, refer to Steps 5 through 7. If no additional spring adjustment is available, then both belts must be replaced with a new matched set.

NOTE: Always replace belts in matched sets.

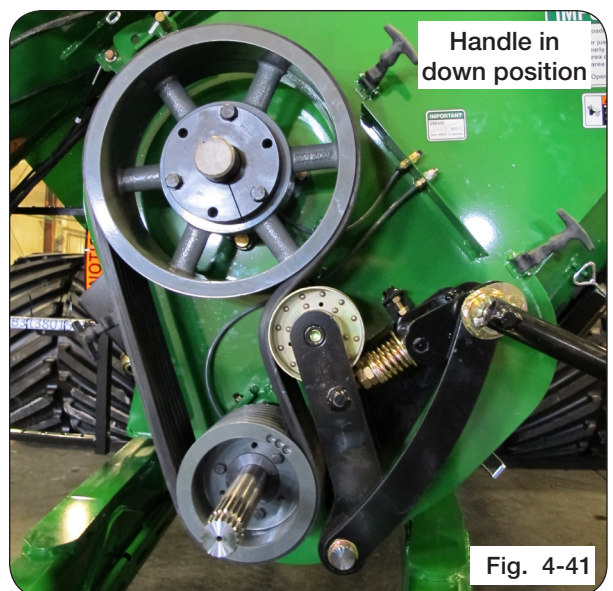
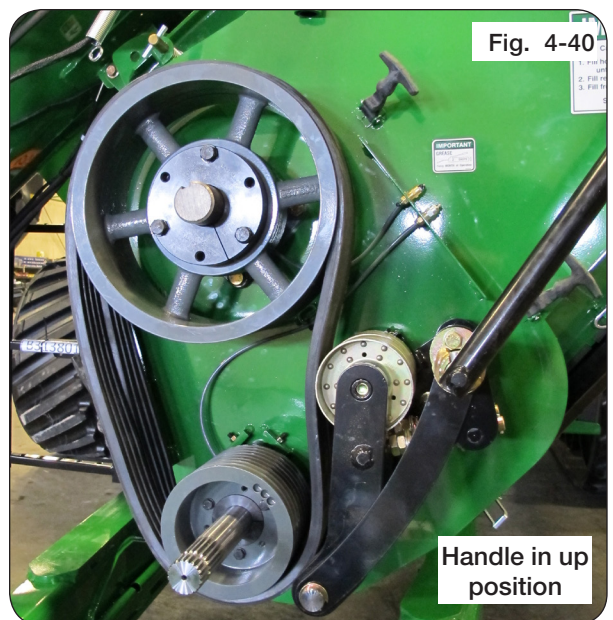
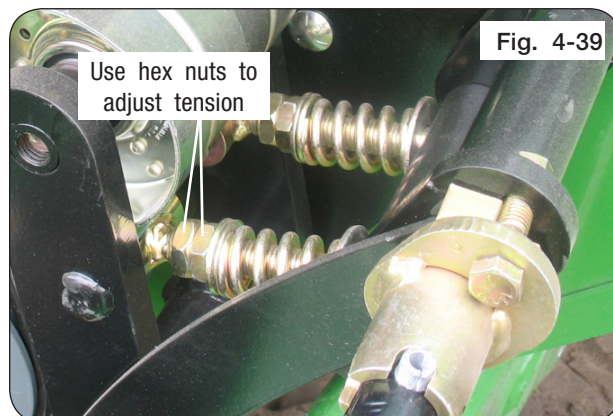

V-Belt Alignment

1. Pulleys must be aligned with the fixed idler. Belts should be centered on idler for longest belt life. (Fig. 4-42)



2. After tightening taper-lock bushing hardware, lay a straight edge across face of the drive and driven belt pulleys to ensure alignment between the grooves on the pulleys. (FIG. 4-43)

Split Tapered Bushings

Check annually for tight engagement to drive-shaft. Torque three bolts progressively to values shown:

- 1 3/4" Bore (Gearbox) - 30 ft.-lbs.
- 2 1/4" Bore (Horizontal Auger) - 75 ft.-lbs.

Some gap must remain between flange & hub when bushing is properly tightened.

To remove from shaft, remove capscrews and insert them in tapped holes in bushing flange. Tighten progressively until bushing disengages.

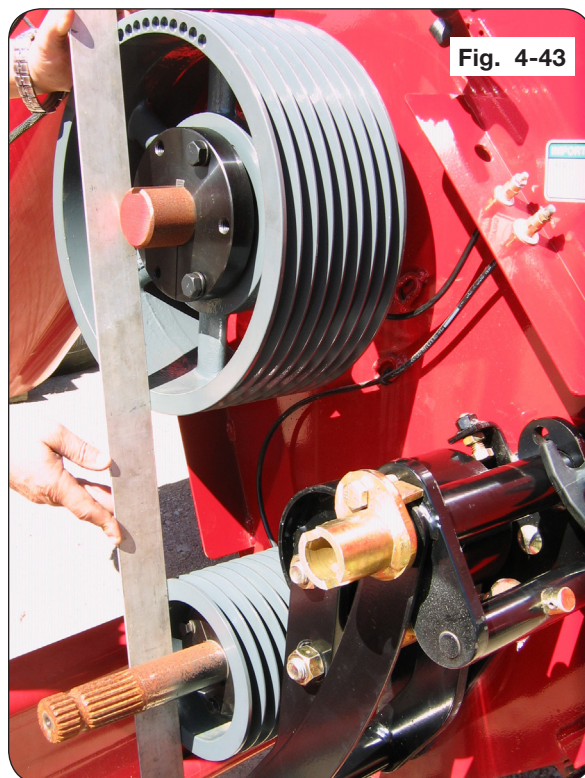

Verify Telescoping PTO Shaft Length

WARNING

- PROPER EXTENDED AND COLLAPSED LENGTHS OF THE TELESCOPING PTO SHAFT MUST BE VERIFIED BEFORE FIRST OPERATION WITH EACH TRACTOR. IF THE EXTENDED LENGTH OF THE PTO SHAFT IS NOT SUFFICIENT, IT MAY BECOME UNCOUPLED IN OPERATION AND CAUSE SERIOUS INJURY OR DEATH FROM CONTACT WITH UNCONTROLLED FLAILING OF PTO SHAFT ASSEMBLY COMPONENTS.

IMPORTANT

- Check the length of the telescoping members to ensure the driveline will not bottom out or separate when turning and/or going over rough terrain.

Verify distance between the end of tractor PTO shaft and center of drawbar hole is set to 20 inches.

An excessive collapsed length can result in damage to the PTO driveline and attached components. This is most likely to occur during extreme turning angles and/or travel over rough terrain. Conditions are amplified on tractors with tracks operating in uneven terrain, particularly rice levies. Damaged driveline components can result in unsafe operation and severely reduced driveline component life.

NOTE: Do not exceed 10 degrees beyond a straight pull line while operating the PTO. To verify proper extended and collapsed lengths, use the following procedure:

1. Fully collapse PTO shaft and measure length "L" (Figure 4-44).

Enter here: _____ (1)

(Verify that outer tube does not bottom out on surrounding plastic shield components).

2. Pull apart PTO telescoping shaft ends and measure lengths "T" & "C" (Figure 4-45)

Add "T" + "C" measurements together

Enter total here: _____ (2)

3. Calculate maximum recommended extended length:

- a. Subtract line 1 from line 2

Enter here: _____ (a)

- b. Divide line (a) by 2

Enter here: _____ (b)

- c. Add line (b) to line 1.

Enter here: _____ (c)

- d. Subtract 3 inches from line (c)

Enter here: _____ (d)

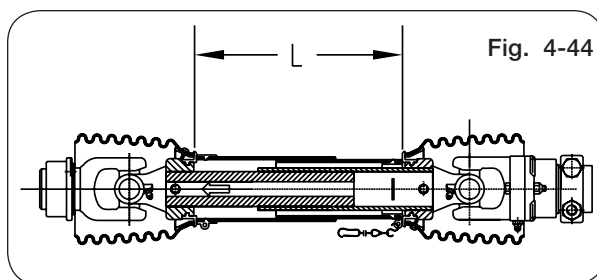

Fig. 4-44

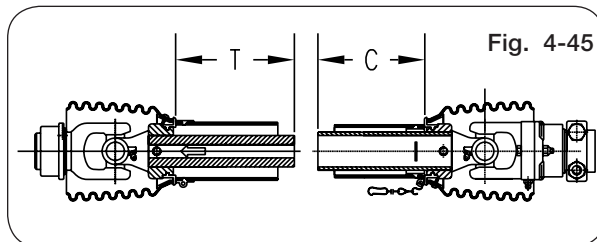
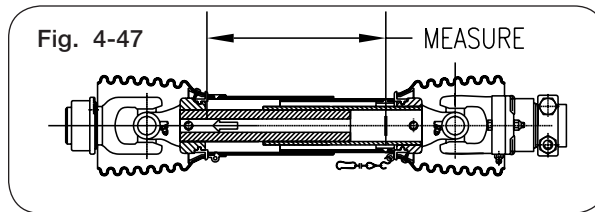
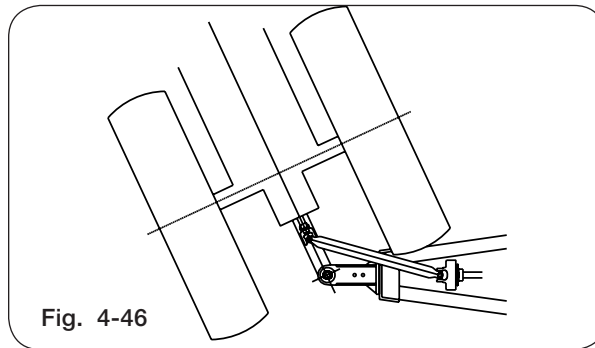

Fig. 4-45

This is the maximum recommended extended length.

Verify Telescoping PTO Shaft Length (continued)

4. Hitch tractor drawbar to cart, ensuring that tractor and cart are on level ground and coupled as straight as practical.
5. Connect PTO shaft to tractor, and measure length “L” from same points as used in step 1. Ensure that this measurement does not exceed the maximum recommended extended length calculated in step 3 above. If necessary, choose a shorter drawbar position, or obtain a longer PTO shaft assembly before operating cart.
6. Position the tractor to obtain the tightest turning angle, relative to the cart (Figure 4-46).
7. Measure the length “L” from the same points as used in step 1. **This distance must be at least 1.5 inches greater than the distance measured in step 1.** If necessary, adjust the length of the PTO shaft by cutting the inner and outer plastic guard tubes and inner and outer sliding profiles by the same length. Round off all sharp edges and remove burrs before greasing and reassembling shaft halves. (FIG. 4-47)



PTO Shaft and Clutch

Length Adjustment (Figs. F1 - F4)

NOTE: Maximum operating length, refer to “Verify Telescoping PTO Shaft Length” in this Section.

1. To adjust length, hold the half-shafts next to each other in the shortest working position and mark them.
2. Shorten inner and outer guard tubes equally.
3. Shorten inner and outer sliding profiles by the same length as the guard tubes.
4. Round off all sharp edges and remove burrs. Grease sliding profiles.

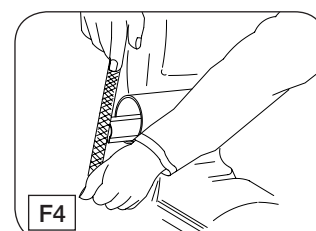
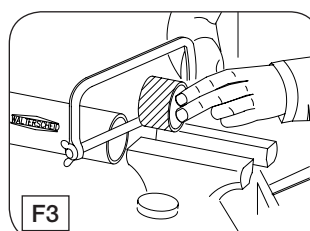
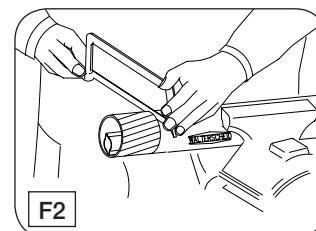
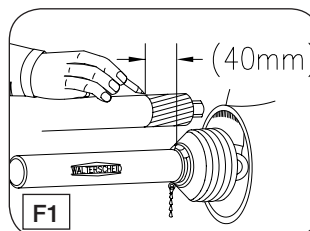

⚠ WARNING

- CHECK THE LENGTH OF THE TELESCOPING MEMBERS TO INSURE THE DRIVELINE WILL NOT BOTTOM OUT OR SEPARATE WHEN TURNING AND/OR GOING OVER ROUGH TERRAIN.

To Dismantle Guard (Figs. J1 - J4)

1. Remove locking screw.
2. Align bearing tabs with cone pockets.
3. Remove half-guard.
4. Remove bearing ring.

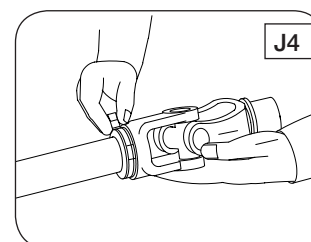
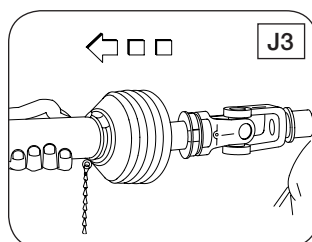
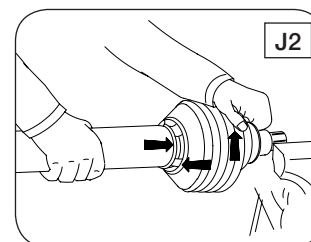
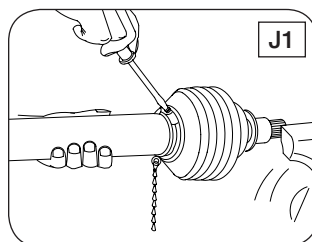

PTO Shaft and Clutch (continued)

To Assemble Guard (Figs. K1 - K5)

1. Grease yoke groove and inner profile tube.
2. Fit bearing ring in groove with recesses facing profile tube.
3. Slip on half-guard.
4. Turn cone until it engages correctly.
5. Install locking screw.

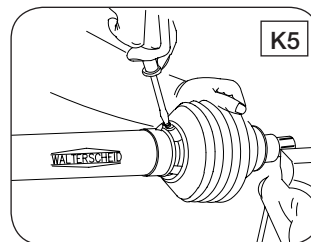
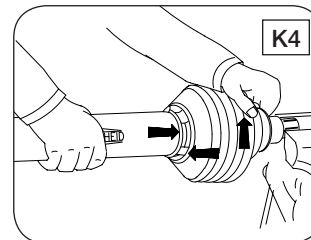
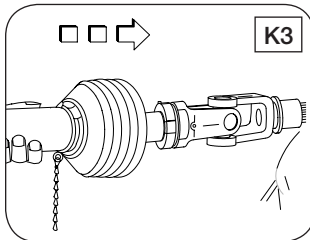
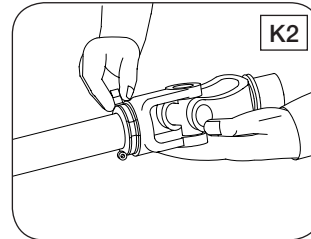
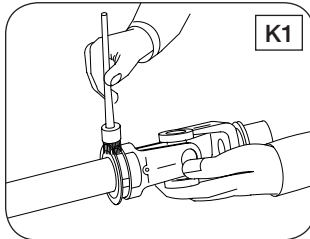

To Assemble Cone (Figs. L1 - L3)

1. Dismantle guard (Figs. J1 - J3). Remove old cone (e.g. cut open with knife). Take off chain. Place neck of new cone in hot water (approx 80o C / 180o F) and pull onto bearing housing (Fig. L1).
2. Turn guard cone into assembly position (Fig. L2). Further assembly instructions for guard (Figs. K1 - K5).
3. Reconnect chain if required (Fig. L3).

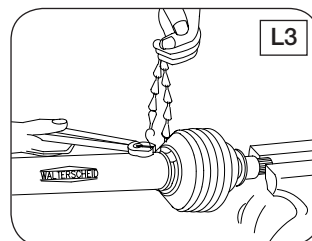
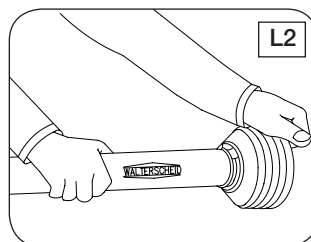
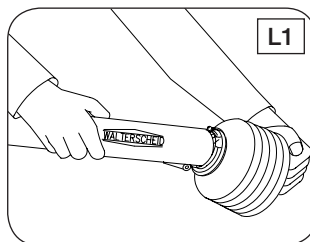

PTO Quick Disconnect

Coupling

Slide clamp yoke or cut-out clutch onto connecting shaft. Make sure the location hole for the clamping cone is positioned above the annular groove of the connecting shaft. Screw appropriate clamping cone into the location hole. Slightly moving the clamp yoke or clutch to-and-fro in the axial direction will help drive in the clamping cone. Check the clamp yoke or clutch for a tight and safe fit and continue to check at regular intervals. Retighten the clamping cone as necessary. Torque clamping cone to 75 ft.-lbs.

When over loading occurs, the clutch disengages and will repeatedly attempt to reset. The clutch will create a repeated “clicking” noise when resetting. Torque demand must decrease for clutch to reset.

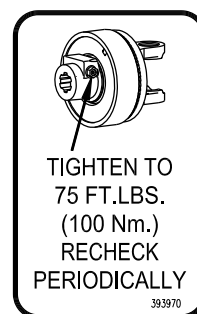
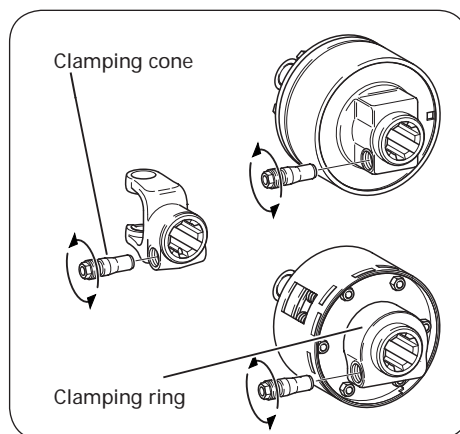
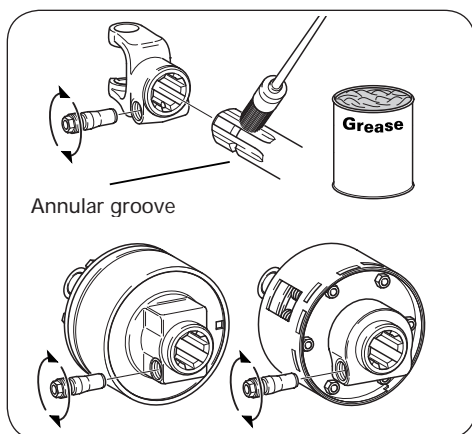

Uncoupling

First dislodge the clamping cone with a punch and hammer from its current position. Unscrew the clamping cone a partial turn. Use the punch and hammer again to help alleviate the torque resistance on the wrench, if necessary. After a few cycles, the clamping cone will move freely with low torque resistance for the removal process.

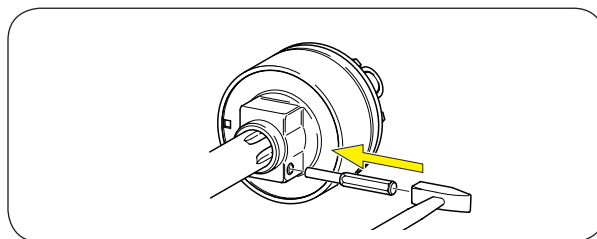

Tarp Troubleshooting Inspection & Maintenance

PROBLEM	SOLUTION
TARP SAGS IN MIDDLE AREAS	<ol style="list-style-type: none"> 1. BOWS MAY BE BENT OR ADJUSTED TOO LOW 2. MISSING OR LOOSE RIDGE STRAP REPLACE OR RETIGHTEN 3. TENSION MAY BE TOO LOOSE. U-JOINT MAY NEED TO BE ADJUSTED ON SPLINED SHAFT TO PROVIDE MORE TENSION
HOLES OR TEARS IN TARP	<ol style="list-style-type: none"> 1. CONSULT YOUR LOCAL DEALER FOR REPAIRS 2. ORDER TARP REPAIR KIT (9005581) FROM DEALER 3. WHEN NEW TARP OR PARTS ARE NEEDED ALWAYS REPLACE WITH ORIGINAL PARTS

Inspection and Maintenance

⚠ WARNING

- TO PREVENT PERSONAL INJURY OR DEATH, DO NOT ALLOW ANYONE ON A CLOSED TARP. TARP SYSTEM IS NOT DESIGNED TO SUPPORT A PERSON.
- FALLING OBJECTS CAN CAUSE SERIOUS INJURY OR DEATH. REMOVE ACCUMULATED WATER/SNOW/ICE OR ANY OTHER OBJECTS FROM TARP BEFORE OPENING TARP.

IMPORTANT

- *Do not open or close tarp while moving or in high wind conditions. Damage to the tarp may occur.*
- *Tarp should not be used if it is torn or the bungee cords are frayed or show damage. If water pools on the tarp adjust tension of tarp cables and/or arm springs as required.*

Periodic preventive maintenance should be practiced. Inspect tarp and hardware often for abrasions or loosened bolts that may need adjustment and/or repair. Check bungee cords for wear and adjust tension at the beginning of the season and again half way through the season.

Tears in tarp should addressed before further tarp operation. If water pools on tarp, adjust tension of tarp cables and/or crank handle tension.

If installed correctly, tarp should always operate as well as when first installed. If tarp does not pass this simple inspection, make all appropriate repairs or adjustments immediately before serious damage occurs.

Electrical System Schematic

GRAIN CART WIRES

- White -- Ground
- Green -- Right amber flashing lamp
- Yellow -- Left amber flashing lamp
- Brown -- Tail light
- Black -- Interior & Auger Lights
- Red -- Brake Lights
- Blue -- NOT USED

SAE SEVEN-POINT CONNECTOR PLUG

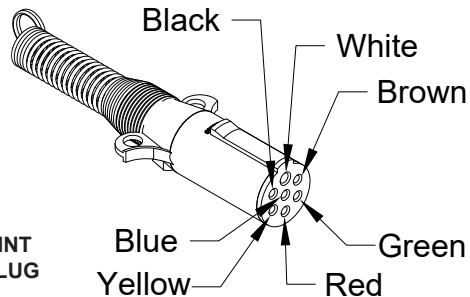

ELECTRIC TARP

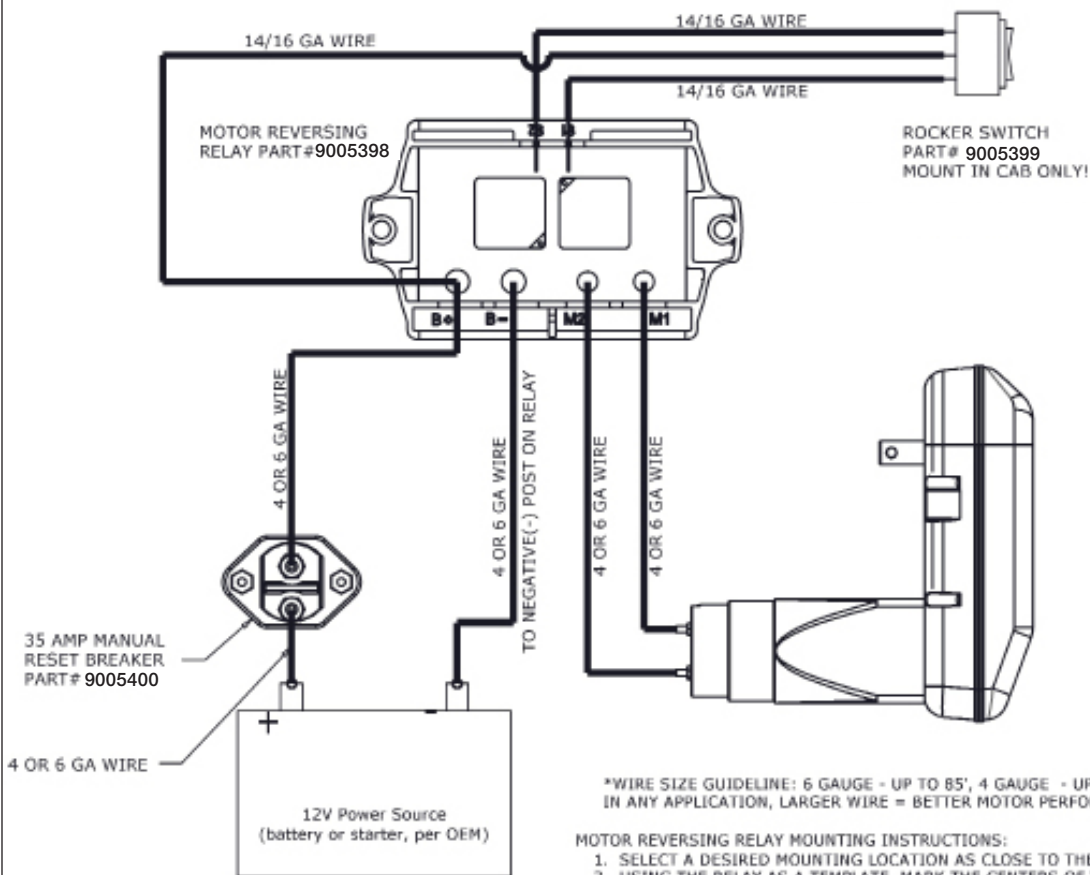

NOTE: See separate electric tarp manual for additional information.

- MOTOR REVERSING RELAY MOUNTING INSTRUCTIONS:**
1. SELECT A DESIRED MOUNTING LOCATION AS CLOSE TO THE BATTERY AS POSSIBLE.
 2. USING THE RELAY AS A TEMPLATE, MARK THE CENTERS OF THE MOUNTING HOLES.
 3. USING A 1/4" DRILL BIT, DRILL THE HOLES MARKED IN THE PREVIOUS STEP.
 4. MOUNT THE RELAY USING THE PROVIDED BOLTS AND NUTS.
 5. WIRE THE RELAY ACCORDING TO THE WIRING DIAGRAM.
 6. APPLY DIELECTRIC GREASE TO ALL ELECTRICAL CONNECTIONS.

Electrical System Schematic

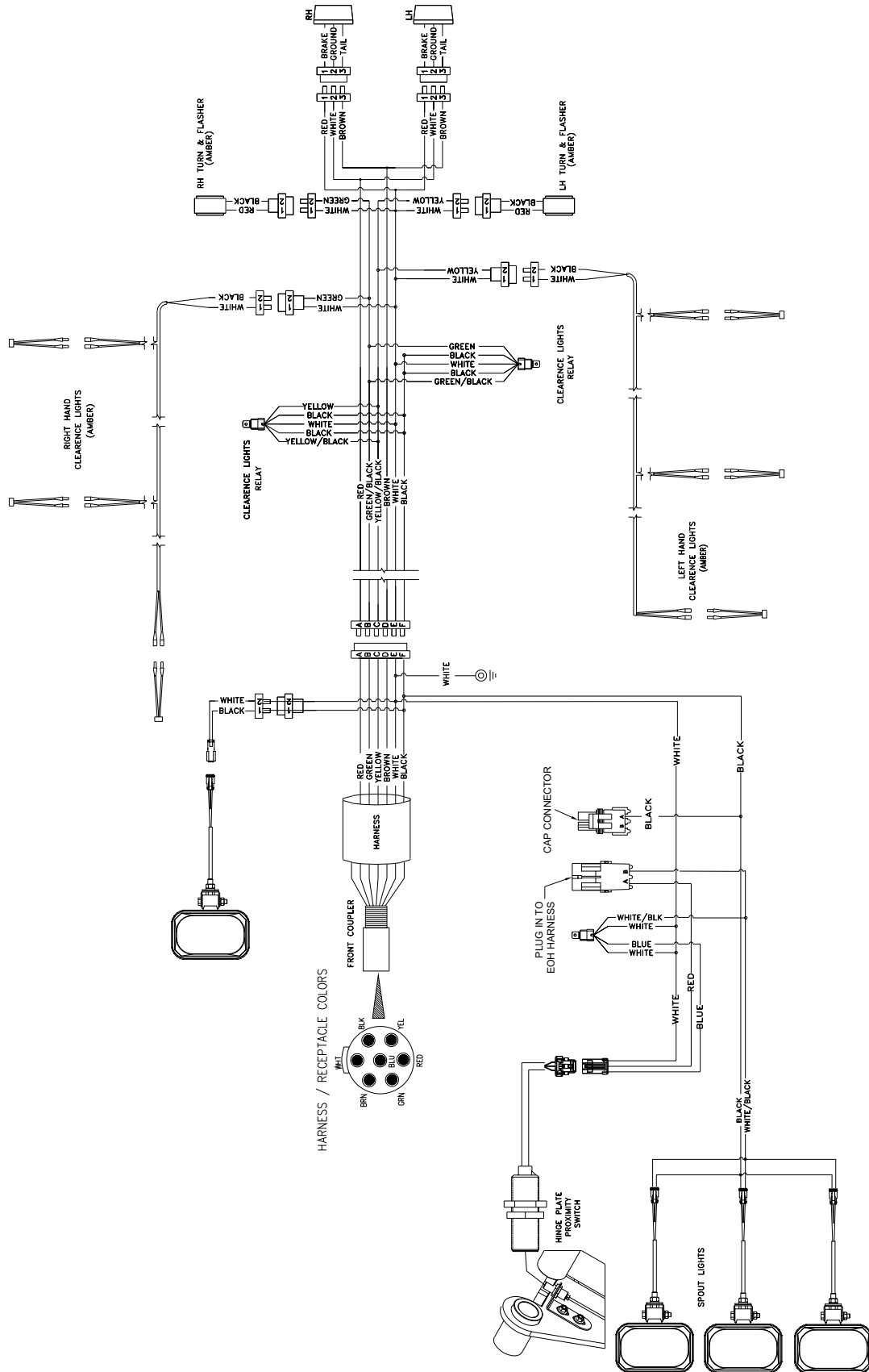

(EOH) System Schematic (Opt.) - 5 Function Control Grip

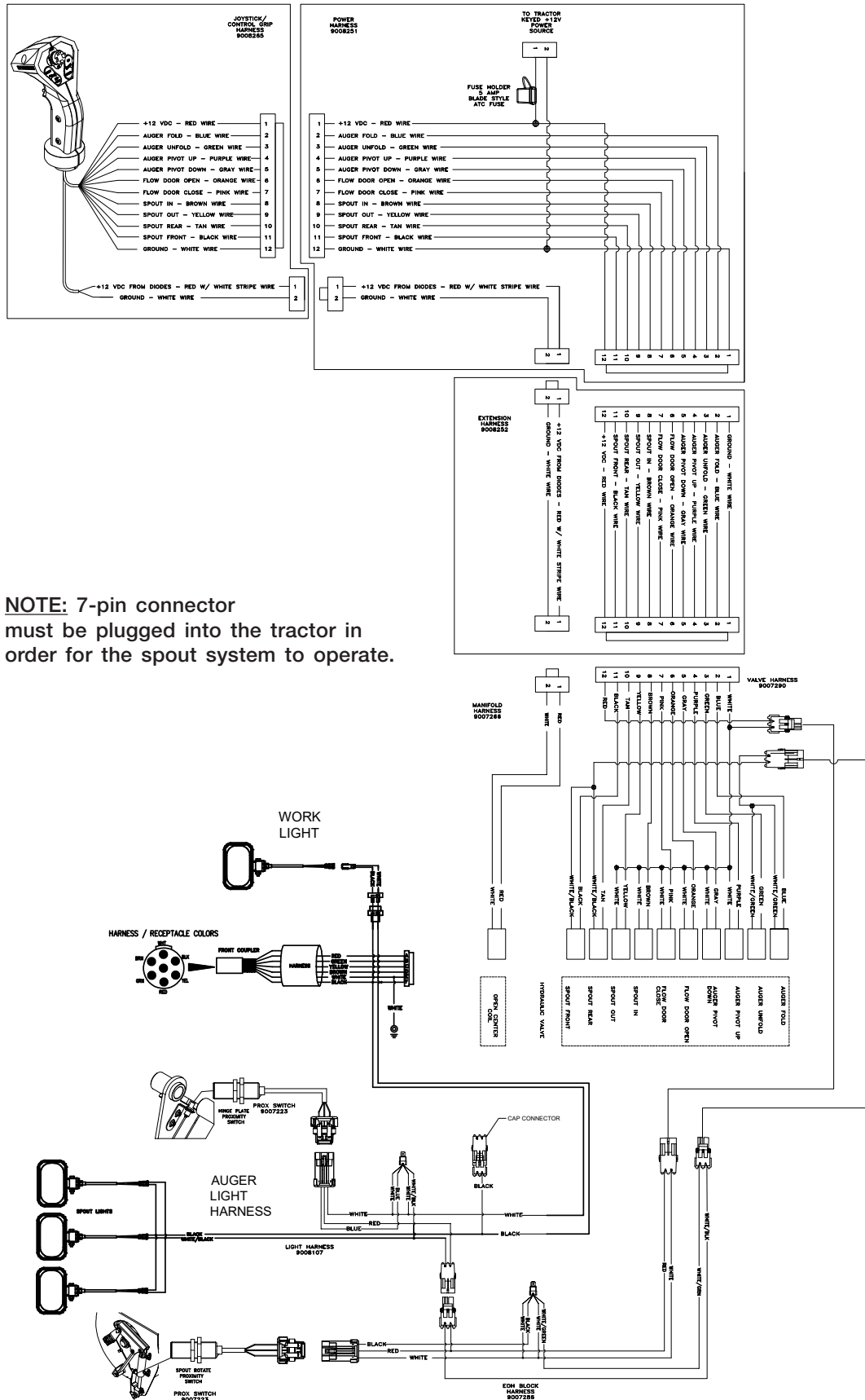

NOTE: 7-pin connector must be plugged into the tractor in order for the spout system to operate.

5 Function Remote Option Electrical Schematic

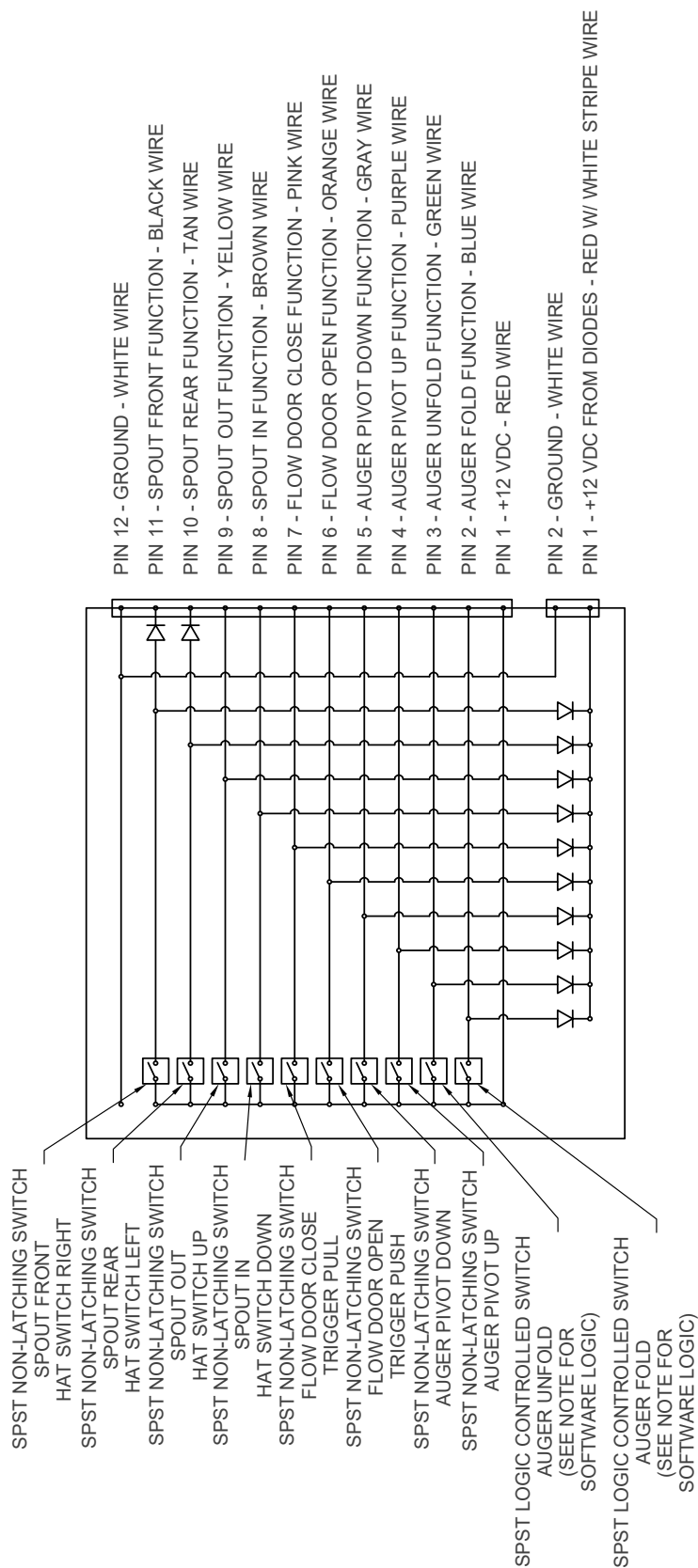

Software Logic:

Auger fold and unfold functions will stay on for 60 seconds when either is pressed twice in rapid succession (less than or equal to 1/3 of a second). Pressing fold or unfold during the timed cycle will cancel the timed cycle.

**Optional Electric Over Hydraulic Valve Electric Schematic
5 Spool**

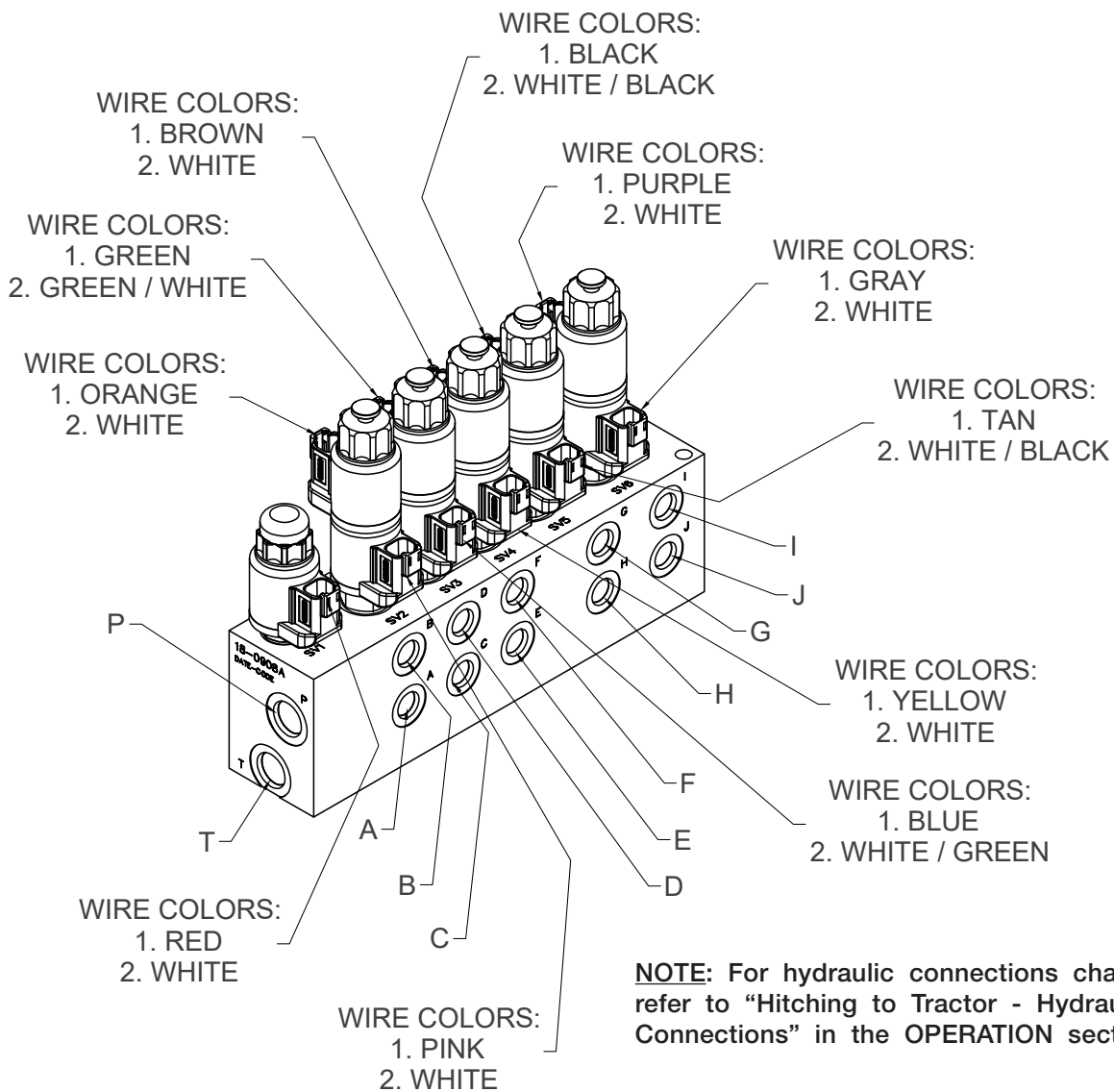

PORT	END OF CYLINDER	FUNCTION
A	BUTT END	FLOW DOOR
B	RAM END	FLOW DOOR
C	RAM END	AUGER FOLD
D	BUTT END	AUGER FOLD
E	RAM END	SPOUT TILT
F	BUTT END	SPOUT TILT
G	RAM END	JOYSTICK / SPOUT ROTATE
H	BUTT END	JOYSTICK / SPOUT ROTATE
I	BUTT END	AUGER TILT
J	RAM END	AUGER TILT
P		TRACTOR PRESSURE
T		TRACTOR RETURN

Wheels and Tires

Wheel Nut Torque Requirements

CAUTION

- IMPROPERLY TORQUED WHEEL NUTS/BOLTS CAN CAUSE A LOSS OF IMPLEMENT CONTROL AND MACHINE DAMAGE. TORQUE WHEEL NUTS/BOLTS TO VALUES IN TABLE. CHECK TORQUE BEFORE USE, AFTER ONE HOUR OF UNLOADED USE OR AFTER FIRST LOAD, AND EACH LOAD UNTIL WHEEL NUTS/BOLTS MAINTAIN TORQUE VALUE. CHECK TORQUE EVERY 10 HOURS OF USE THERE-AFTER. AFTER EACH WHEEL REMOVAL START TORQUE PROCESS FROM BEGINNING. WARRANTY DOES NOT COVER FAILURES CAUSED BY IMPROPERLY TORQUED WHEEL NUTS/BOLTS.

Failure to check torque before first load may damage wheel nut/bolt seats. Once seats are damaged, it will become impossible to keep nuts/bolts tight. Tighten nuts/bolts to applicable torque value shown in table. Start all nuts/bolts by hand to prevent cross threading. Torque nuts/bolts in the recommended sequence as shown in Diagrams 1 & 2.

NOTE: Do not use anti-seize on wheel hardware.

WHEEL HARDWARE	
SIZE	FOOT-POUNDS
7/8-14 (UNF)	440 ft.-lbs.
M22x1.5	475 ft.-lbs.

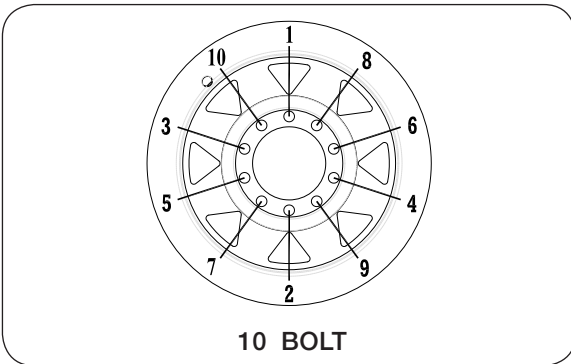

DIAGRAM 1

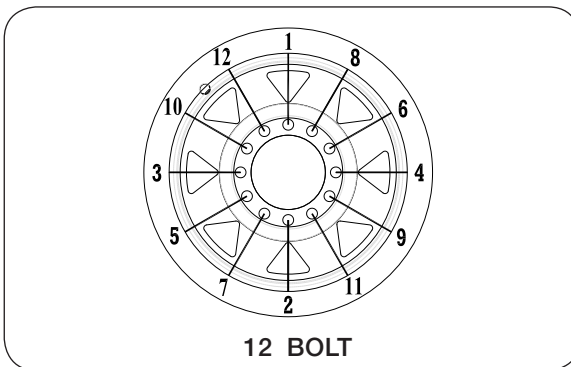

DIAGRAM 2

Wheels and Tires (continued)

Tire Pressure

The following is to be used as a general guide for tire inflation and figures can vary depending on specific brand of tire used. It is important that tires are inspected after unit is loaded. Start with minimum pressure. The tire should stand up with no side-wall buckling or distress as tire rolls. Record the pressure needed to support the full load and maintain this pressure to achieve proper tire life. Do not exceed maximum recommended tire pressure. Each tire must be inflated to 35 PSI max to seat the beads, deflated to 5-10 PSI, then reinflated to the tire's max PSI when mounting.

Tire Pressure for Grain Carts

Tire Make	Tire Size	Load Index / Ply Rating	Max. PSI
Firestone	23.1x26 R-3	12	32
	23.1x26 R-1	12	32
	28Lx26 R-3	12	26
	24.5x32 R-3	12	32
	24.5x32 R-1	12	32
	30.5x32 R-1	14	28
	30.5x32 R-3	14	28
	30.5x32 R-3	16	34
	30.5x32 R-1	16	26
	35.5x32 R-3	20	36
	76x50.00x32 HF-3	16	40
	76x50.00x32 HF-3	20	50
	800/65R32 R-1W	172A8	44
	800/60R32 R-3	181B	46
	900/65R32 R-3	191B	46
	900/60R32 R-1	176A8	44
	1250/50R32F IF/CFO R-1WNP	201D	46
	1250/50R32F IF/CFO R-1W	188B	30
	520/85R38 R-1	155A8	29
	520/85R38 R-1	173A8	64
	480/80R42 R-1	151A8	36
	520/85R42 R-1	157A8	29
	520/85R42 R-1	165A8	51
	520/85R42 IF/CFO R-1	169A8/B	35
	520/85R42 R-1W	169B	35
	420/80R46 R-1	151A8	44
	480/80R46 R-1	158A8	44
380/90R46 R-1	152B	51	

Wheels and Tires (continued)

Tire Pressure (continued)

Tire Make	Tire Size	Load Index / Ply Rating	Max. PSI
Titan/Goodyear	23.1x26 R-3	10	26
	23.1x26 R-1	10	26
	24.5R32 R-1	169A8/B (5-Star)	48
	24.5x32 R-3	12	32
	24.5x32 R-1	12	32
	30.5x32 R-3	16	26
	30.5x32 R-3	14	22
	30.5x32 R-1	14	22
	480/80x42 R-1	166A8	23
<hr/>			
	1100/45R46 F-1W	195D	35
Mitas	650/75R32 R-1W	172A8	58
	900/60x32 R-1W	176A8	41
	900/70R32 R-1W	188A8	53
	1050/50x32 R-1W	178A8	41
	1250/50R32 R-1W	188A8	41
	900/60x38 R-1W	181A8	44
	520/85x42 R-1W	162A8	44
	650/65x42 R-1W	168A8	44
<hr/>			
Alliance	35.5LR32	193A8	44
	900/60R32 R-1W	192D	46
	1050/50R32 R-1W	185A8	63
	1250/50R32 R-1W	201B	46
<hr/>			
Trelleborg	VF1050/50R32 R-1	198D	52
	900/50R32 R-1W	181A8	55
	900/60x32	176LI	44
	850/55R42 R-1W	161A8	32

Wheels and Tires (continued)

Tire Warranty

For questions regarding new tire warranty, please contact your local original equipment tire dealer. Used tires carry no warranty. Following are phone numbers and Websites for your convenience:

Firestone	www.firestoneag.com Phone 800-847-3364
Titan or Goodyear	www.titan-intl.com Phone 800-USA-BEAR Fax 515-265-9301
Trelleborg	www.trelleborg.com Phone 866-633-8473
Continental/Mitas	www.mitas-tires.com Phone 704-542-3422 Fax 704-542-3474
Alliance	www.atgtire.com Phone 781-325-3801

Complete Torque Chart

Capscrews - Grade 5

NOTE:

- Grade 5 capscrews can be identified by three radial dashes on the head.
- For wheel torque requirements, refer to Wheels and Tires.
- Tighten U-bolts evenly and equally to have the same number of threads exposed on each end.



SIZE	FOOT POUNDS	NEWTON METERS
1/4-20	8-10	11-13
1/4-28	9-11	12-15
5/16-18	15-17	20-23
5/16-24	17-19	23-26
3/8-16	25-28	34-38
3/8-24	28-31	38-42
7/16-14	40-45	54-61
7/16-20	45-50	61-68
1/2-13	62-68	84-92
1/2-20	68-75	92-102
9/16-12	90-98	122-133
9/16-18	100-110	134-148
5/8-11	120-135	162-183
5/8-18	124-137	168-186
3/4-10	200-220	270-300
3/4-16	210-230	285-310
7/8-9	330-350	425-475
7/8-14	360-380	460-515
1-8	500-525	675-710
1-14	540-560	730-760
1 1/8-7	600-635	815-860
1 1/8-12	665-700	920-950
1 1/4-7	850-895	1150-1215
1 1/4-12	940-990	1275-1340
1 3/8-6	1125-1175	1525-1590
1 3/8-12	1280-1335	1735-1810
1 1/2-6	1500-1560	2035-2115
1 1/2-12	1685-1755	2285-2380

IMPORTANT

- *Follow these torque recommendations except when specified in text.*

Complete Torque Chart

Capscrews - Grade 8



NOTE:

- Grade 8 capscrews can be identified by six radial dashes on the head.
- For wheel torque requirements, refer to Wheels and Tires.
- Tighten U-bolts evenly and equally to have the same number of threads exposed on each end.

SIZE	FOOT POUNDS	NEWTON METERS
5/16-18	20-22	27-30
5/16-24	21-23	28-31
3/8-16	35-39	47-53
3/8-24	36-41	49-55
7/16-14	54-58	73-78
7/16-20	55-60	75-80
1/2-13	82-88	110-120
1/2-20	94-99	125-135
9/16-12	127-134	170-180
9/16-18	147-155	199-210
5/8-11	160-170	215-230
5/8-18	165-175	225-235
3/4-10	280-295	380-400
3/4-16	330-365	445-495
7/8-9	410-430	555-580
7/8-14	420-440	570-595
1-8	630-650	850-880
1-14	680-700	920-950
1 1/8-7	900-930	1220-1260
1 1/8-12	930-950	1260-1290
1 1/4-7	1250-1300	1695-1760
1 1/4-12	1280-1320	1735-1790

IMPORTANT

- Follow these torque recommendations except when specified in text.

Hydraulic Fittings - Torque and Installation

SAE Flare Connection (J. I. C.)

1. Tighten nut with finger until it bottoms the seat.
2. Using a wrench, rotate nut to tighten. Turn nut 1/3 turn to apply proper torque.

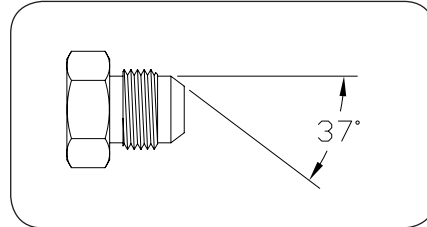

SAE Straight Thread O-Ring Seal

1. Ensure jam nut and washer are backed up to the back side of smooth portion of elbow adapter.
2. Lubricate o-ring.
3. Thread into port until washer bottoms onto spot face.
4. Position elbows by backing up adapter.
5. Tighten jam nut.

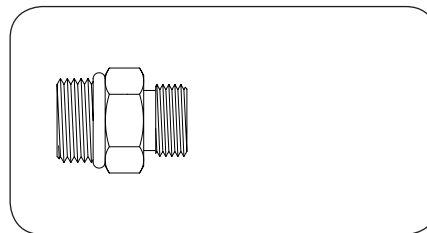

Section V

Parts

Please visit www.unverferth.com/parts/ for the most current parts listing.

Decals.....	5-2
Hitch & Tongue Components.....	5-4
Ladder Components.....	5-6
Touch-Up Paint.....	5-7
Axle & Hub Components - Model 1196 Single Wheels.....	5-8
Axle & Hub Components - Model 1396 Single Wheels.....	5-10
Hopper Components.....	5-12
Walking Tandem Assembly Components.....	5-14
Walking Tandem Mounting Components.....	5-16
Wheels & Tires.....	5-17
Dual Wheels & Tires.....	5-17
Track Axle Components - Model 1196 & 1396 w/36x148, 42x131, 42x148, & 50x148.....	5-18
Track Axle Components - Models 1196 w/36x112 & 36x131.....	5-20
Track Panel Kit Components.....	5-21
Sideboards - Model 1196.....	5-22
Sideboards - Model 1396.....	5-23
Horizontal Auger Components.....	5-24
Vertical Auger Flighting Components.....	5-26
Lower Auger Door & Cover Components.....	5-28
Lower Auger Linkage Components.....	5-30
Idler Assembly Components.....	5-32
Auger Tube Components.....	5-34
Auger Grease Bank Components.....	5-38
EOH Valve Functions & Wire Locations 5 Spool (Optional).....	5-39
EOH Valve Assembly Components 5 Spool (Optional).....	5-40
EOH Tractor Circuit Hydraulic Components (Optional).....	5-42
Optional Spout Rotate and Tilt Hydraulic Components.....	5-44
Auger Pivot Hydraulic Components.....	5-46
Auger Fold Hydraulic Components - 5 Function Hydraulic Block.....	5-47
Flow Door Circuit Hydraulic Components - 5 Function Hydraulic Block.....	5-48
Cylinders.....	5-49
Hopper Flow Door Components.....	5-50
Downspout Components.....	5-52
Switch Assembly Components (Optional).....	5-54
Rotating Spout Components.....	5-56
Cut Out Clutch PTO Assembly.....	5-58
Cut Out Clutch Components.....	5-59
Gearbox Components.....	5-60
Indicator Assembly.....	5-62
Hopper Rear Electrical Components.....	5-64
Electrical Components - 5 Function Control Grip.....	5-66
Weather Guard Tarp.....	5-68
Hydraulic Jack - Kit #294142B (Optional).....	5-70
Video System (Optional).....	5-71

FOR SCALE INFORMATION, PLEASE REFER TO YOUR SCALE MANUAL.

FOR TRACK INFORMATION, PLEASE REFER TO YOUR TRACK MANUAL.

FOR UHARVEST INFORMATION, PLEASE REFER TO YOUR UHARVEST MANUAL.

FOR ELECTRIC TARP INFORMATION, PLEASE REFER TO YOUR ELECTRIC TARP MANUAL.

FOR WATER DELIVERY SYSTEM INFORMATION, PLEASE REFER TO YOUR WATER DELIVERY SYSTEM MANUAL.

Brent 1196/1396 Right-Hand Unload — Parts

Decals

Please visit www.unverferth.com/parts/ for the most current parts listing.

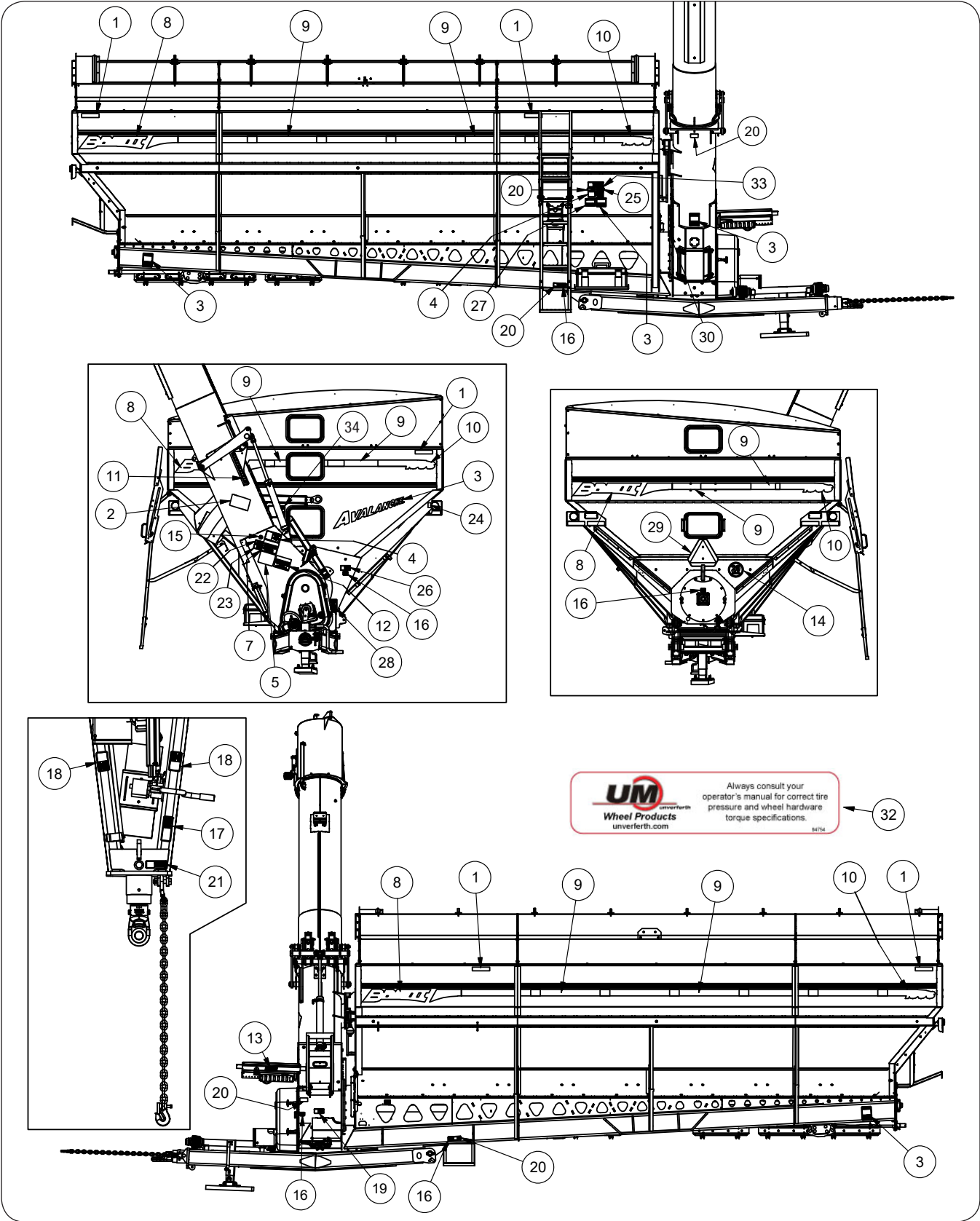

Brent 1196/1396 Right-Hand Unload — Parts

Decals

Please visit www.unverferth.com/parts/ for the most current parts listing.

ITEM	PART NO.	DESCRIPTION	QTY	NOTES
1	9003127	Reflector 2x9 =AMBER=	9	
2	9003474	Decal, DANGER (Electrical Lines)	1	
3	9003475	Decal, WARNING (Cut & Crush)	4	
4	9003476	Decal, WARNING (No Riders)	2	
5	9003477	Decal, IMPORTANT (Operation)	1	
6	9004271	Decal, Avalanche	1	
7	9004966	Decal, IMPORTANT (Cart Loading)	1	
8	9006588	Decal, Brent Logo	4	
9	9006589	Decal, Stripe	15	
10	9006590	Decal, 1196	4	
	9006591	Decal, 1396		
11	9008626	Decal, Flow Control Indicator	1	
12	9008151	Decal, IMPORTANT (PTO Engagement)	1	
13	9008594	Decal, Hose Legend	1	
14	9008714	Decal, Rear SIS 20 MPH	1	
	9008720	Decal, Rear SIS 30 KPH	1	
15	9008715	Decal, Front SIS 20 MPH	1	
	9008721	Decal, Front SIS 30 KPH	1	
16	9008947	Decal, Grease	4	
17	94094	Decal, WARNING (Tongue Rise)	2	
18	95046	Decal, DANGER (Entanglement)	2	
19	95445	Decal, DANGER (Do Not Use Hands)	1	
20	95839	Decal, WARNING (Pinch Point)	5	
21	97575	Decal, CAUTION (Transport Chain)	1	
22	97961	Decal, WARNING (Read Manual)	1	
23	TA1-906109-0	Decal, WARNING (Moving Parts Crush/Cut)	1	
24	91605	Decal, FEMA	1	
25	95008	Decal, CAUTION (Slippery Surface)	1	
26	98229	Decal, WARNING (Falling Equipment)	1	
27	9003478	Decal, DANGER Never Play	1	
28	9005971	Decal, WARNING (Suspension)	1	
29	TA510514	SMV Emblem	1	
30	9008925	Decal, Grease Bank	1	
31	93705	Caulk, for Seams (Clear)	1	Not Shown
32	94754	Decal, UM Wheel Systems	2	
33	9009168	Decal, WARNING (Ladder Lock Pin)	1	
34	900024	Decal, WARNING (High Pressure Oil)	1	

Brent 1196/1396 Right-Hand Unload — Parts

Hitch & Tongue Components

Please visit www.unverferth.com/parts/ for the most current parts listing.

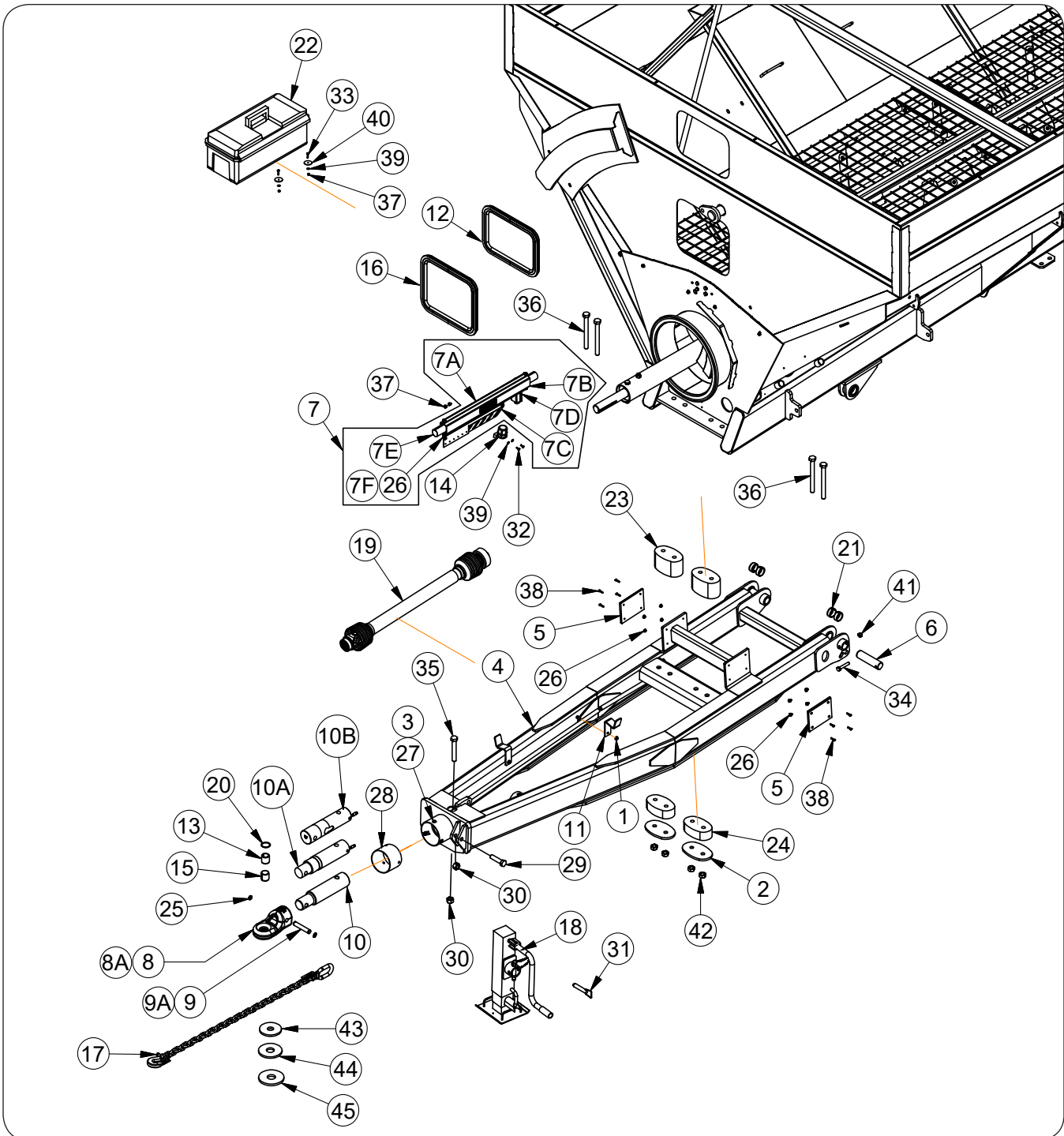

ITEM	PART NO.	DESCRIPTION	QTY	NOTES
1	91267	Flange Nut, 1/2-13UNC Grade 5	2	
2	271687B	Spring Retainer Plate =Black=	2	
3	9390-053	Capscrew, 3/8-16UNC x 3/4 Grade 5	3	
4	271800G	Tongue Weldment =Green=	1	
	271800R	Tongue Weldment =Red=		
5	273237	Nylon Pad	2	

Brent 1196/1396 Right-Hand Unload — Parts

Hitch & Tongue Components

Please visit www.unverferth.com/parts/ for the most current parts listing.

ITEM	PART NO.	DESCRIPTION	QTY	NOTES
6	273368	Pin, 2 Dia. x 7 3/4	2	
7	294128B	Hose Caddy Replacement Kit	1	
7A	294083B	Hose Caddy Weldment =Black=	1	
7B	294085B	Hose Caddy Cover =Black=	1	
7C	294086	Hose Retainer	1	
7D	9000787	Trim - Edge	1/2	Specify in Feet
7E	9003848	Hose Wrap	3	Specify in Feet
7F	91256	Large Flange Capscrew 5/16-18UNC x 3/4 Grade 5	6	
8	282875B	CAT 4 Hitch =Black=	1	Standard 1196 & 1396
8A	271887B	CAT 5 Conversion Kit =Black=	1	1396 Optional - Includes Items CAT 5 Hitch, 9A, 10B, 25, 48
9	282876	CAT 4 Hitch Pin, 1 Dia. x 5 1/2	1	
9A	281691	CAT 5 Hitch Pin, 1 Dia. x 7 3/8	1	
10	284780	Hitch Bar CAT 4	1	Non-Scale
	271894	Hitch Bar CAT 5	1	1396 Optional
10A	9004910	Scale Hitch Bar 3 3/4" Dia. with 16 ft. Cable CAT 4	1	Standard 1196 & 1396
10B	9008119	Scale Hitch Bar 3 3/4" Dia. with 16 ft. Cable CAT 5	1	1396 Optional
11	291974G	PTO Bracket =Green=	2	
	291974R	PTO Bracket =Red=		
12	9008857	Window & Trim Assembly 14 15/32" x 19 21/32"	1	
13	9001917	Tension Bushing	1	
14	9001968	Trailer Connector Holder	1	
15	9002130	Split Tension Bushing, 2 Dia.	1	
16	9008680	Window & Trim Assembly 17 7/32" x 19 21/32"	2	
17	9004898	Chain	1	
18	9005011	Jack	1	
19	9005230	PTO Assembly Complete	1	
20	9005259	O-Ring	4	
21	9005473	Split Tension Bushing, 2 3/8 Dia.	4	
22	9008634	Box Storage	1	
23	9006456	Spring, 4.75 Thick	2	
24	9006457	Spring, 2.50 Thick	2	
25	91192	Retaining Ring, 1"	2	
26	91257	Large Flange Hex Nut, 5/16-18UNC Grade 5	8	
27	9005376	U-Nut	3	
28	271891B	Shield Tube =Black=	1	
29	91299-191	Capscrew, 1-8UNC x 4 Grade 8	1	
30	92199	Center Locknut, 1-8UNC	2	
31	9007632	Jack Pin, 7/8 Dia. x 4 7/8 with Chain	1	
32	9390-003	Capscrew, 1/4-20UNC x 3/4 Grade 5	14	
33	9390-006	Capscrew, 1/4-20UNC x 1 1/4 Grade 5	2	
34	9390-130	Capscrew, 5/8-11UNC x 3 1/2 Grade 5	2	
35	91299-195	Capscrew, 1-8UNC x 6 Grade 8	1	
36	9390-464	Capscrew, 1-8UNC x 10 Grade 5	4	
37	9936	Locknut, 1/4-20UNC Grade 5	2	
38	903171-663	Phillips Head Machine Screw, 5/16-18UNC x 1 1/2	8	
39	9405-064	Flat Washer, 1/4	4	
40	94763	Fender Washer, 2" Dia.	2	
41	95905	Center Locknut, 5/8-11UNC	2	
42	9663	Locknut, 1-8UNC Grade 5	4	
43	281663	Poly Wear Shoe For CAT 3	1	
44	281898	Poly Wear Shoe For CAT 4	1	Standard 1196 & 1396
45	281899	Poly Wear Shoe For CAT 5	1	1396 Optional

Ladder Components

Please visit www.unverferth.com/parts/ for the most current parts listing.

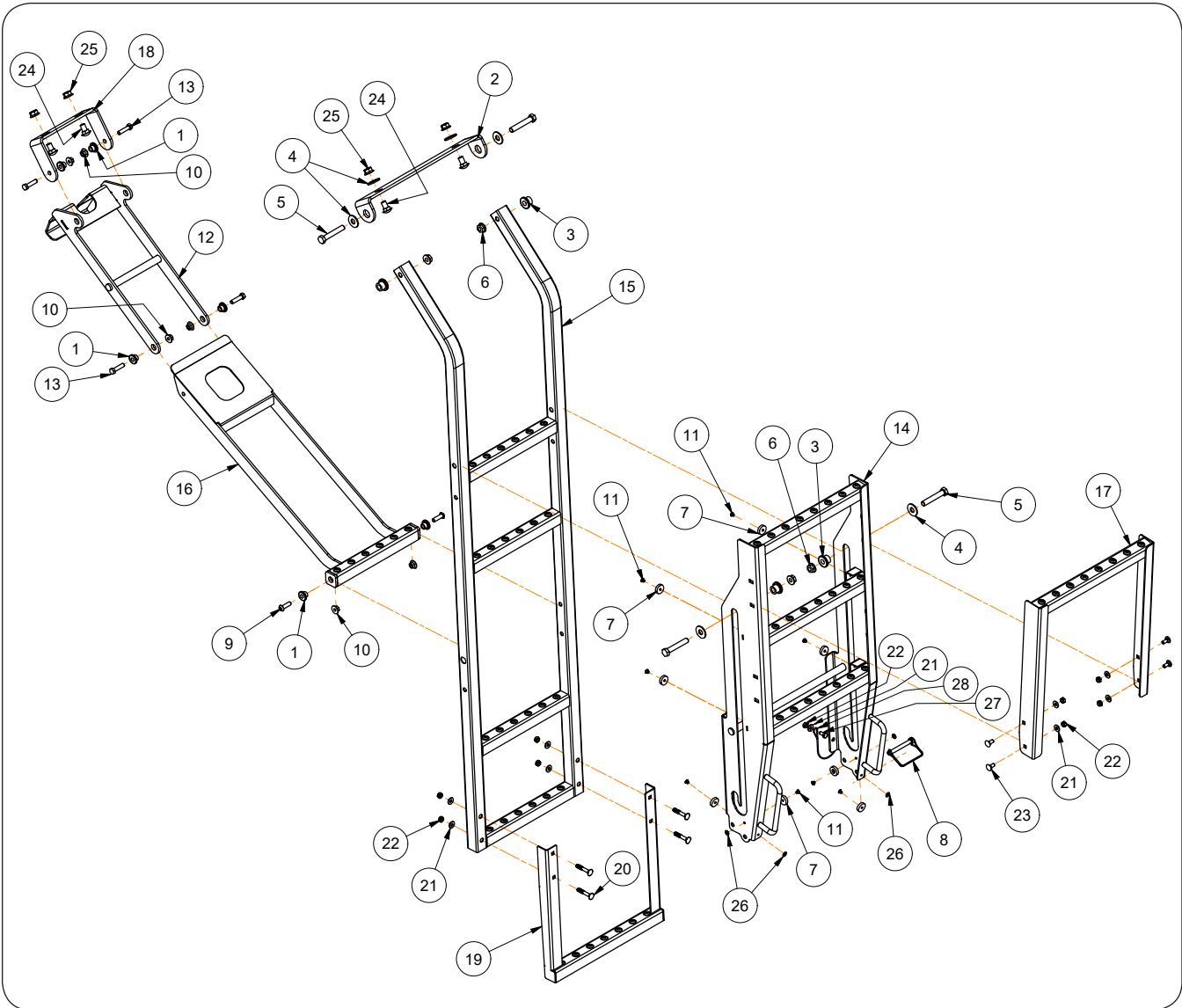

Brent 1196/1396 Right-Hand Unload — Parts

Ladder Components

Please visit www.unverferth.com/parts/ for the most current parts listing.

ITEM	PART NO.	DESCRIPTION	QTY	NOTES
1	2003029	Nylon Bushing, .625" OD x .406" ID x .380"	6	
2	289294B	Plate-Bracket, Ladder =Black=	1	
3	2003030	Nylon Bushing, .875" OD x .531" ID x .563"	4	
4	9405-088	Flat Washer, 1/2" USS	6	
5	9390-107	Capscrew, 1/2"-13UNC x 3" G5	4	
6	9003397	Lock Nut/Top, 1/2"-13UNC	4	
7	TA620384	Plastic Stop, 1" Dia. x .250"	8	
8	9005305	Lynch Pin 3/8" Dia. x 3"	1	
9	99985	Button Head Socket, 3/8"-16UNC x 1 1/4"	2	
10	9008159	Lock Nut/Top, 3/8"-16UNC	6	
11	9003503	Rivet 3/16 X 1/4	8	
12	289284B	Ladder Link Weldment =Black=	1	
13	9390-057	Capscrew, 3/8"-16UNC x 1 1/2" G5	4	
14	289328B	Ladder Extension Weldment =Black=	1	
15	289326B	Ladder Weldment =Black=	1	
16	289715B	Step Weldment =Black=	1	
17	289707B	Ladder Extension Weldment =Black=	1	
18	289840B	Ladder Bracket =Black=	1	
19	289844B	Ladder Weldment =Black=	1	
20	9388-029	Carriage Bolt, 5/16"-18UNC x 2" G5	4	
21	9405-064	Flat Washer, 5/16" ID (1/4" Nominal) USS	9	
22	901527	Lock Nut/Center, 5/16"-18UNC	9	
23	9388-024	Carriage Bolt, 5/16"-18UNC x 3/4" G5	4	
24	9388-102	Carriage Bolt, 1/2"-13UNC x 1" G5	4	
25	91267	Flange Nut 1/2-13 UNC G5	4	
26	9004998	Rivet Burr, 3/16"	4	
27	9390-027	Capscrew, 5/16"-18UNC x 5/8" G5	1	
28	97879	Nylon Lanyard	1	

Touch-Up Paint

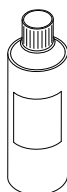

PAINT	SPRAY
Black	97013
Green	97015
Red	97301
Primer, Gray	9500082
Off White	97016
Silver Mist	97012

Brent 1196/1396 Right-Hand Unload — Parts

Axle & Hub Components - Model 1196 Single Wheels

Please visit www.unverferth.com/parts/ for the most current parts listing.

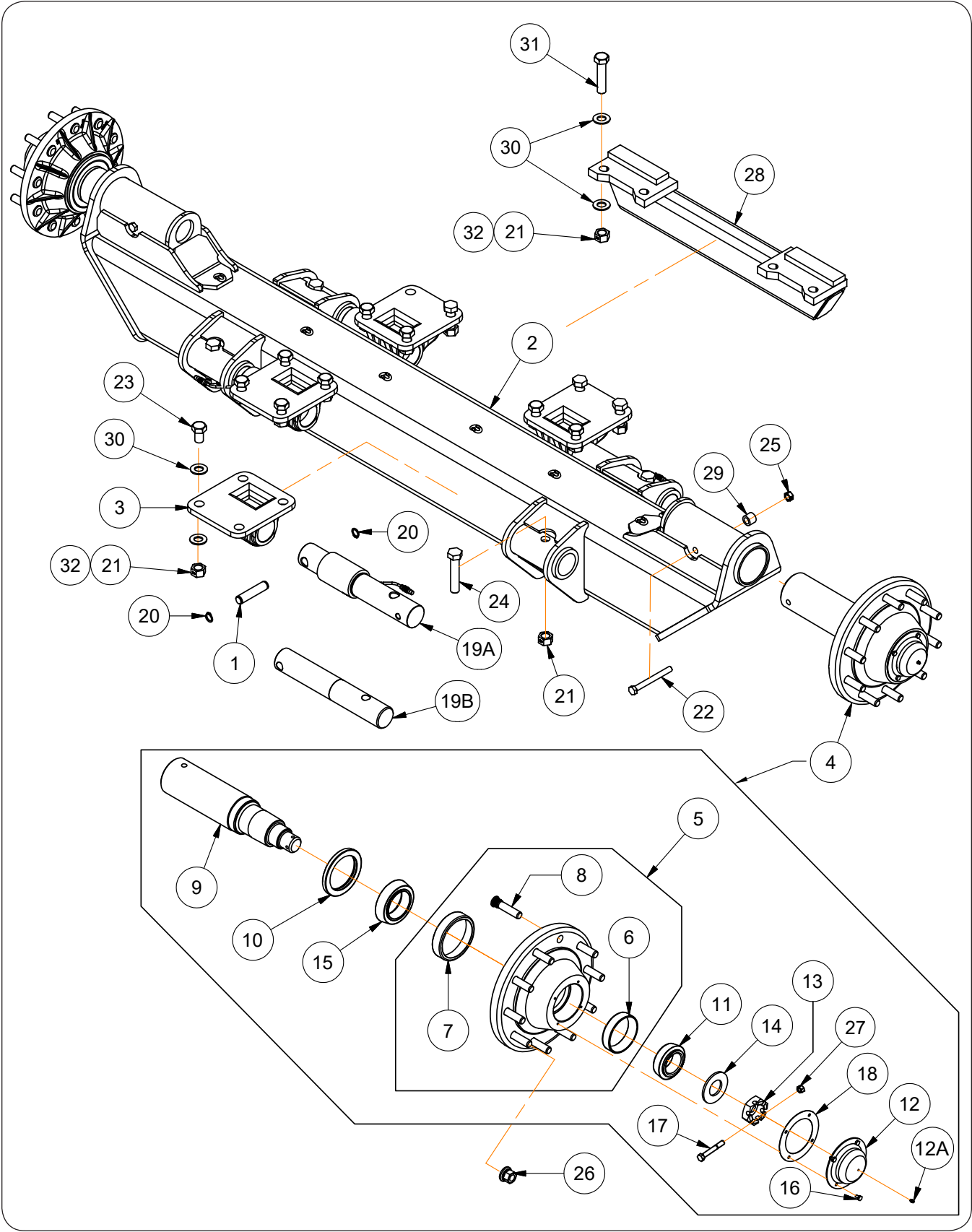

Brent 1196/1396 Right-Hand Unload — Parts

Axle & Hub Components - Model 1196 Single Wheels

Please visit www.unverferth.com/parts/ for the most current parts listing.

ITEM	PART NO.	DESCRIPTION	QTY	NOTES
1	250843	Scale Hitch Pin, 1" Dia x 4 9/16	4	
2	252398G	Axle Weldment - 120 1/2 =Green=	1	4 1/2" Spindle
	252398R	Axle Weldment - 120 1/2 =Red=	1	4 1/2" Spindle
3	268836G	Axle Mount Weldment =Green=	4	
	268836R	Axle Mount Weldment =Red=	4	
4	267284G	Hub & Spindle Asy =Green=	2	
	267284R	Hub & Spindle Asy =Red=		
5	265390G	Hub Sub-Assembly =Green=	2	Model 881 Hub
	265390R	Hub Sub-Assembly =Red=		
6	92462	Outer Bearing Cup	2	Ref #HM212011
7	92476	Inner Bearing Cup	2	Ref #HM218210
8	9007001	Stud Bolt, M22 x 1.5 x 4	20	
9	280240	Spindle 4 1/2" Dia. x 19 7/8	2	2-12UNF Threaded End
10	92455	Seal	2	Ref #43605SA
11	92464	Outer Bearing Cone	2	Ref #HM212049
12	286171G	Hub Cap "Bolt-On Type" =Green=	2	
	286171R	Hub Cap "Bolt-On Type" =Red=		
12A	91160	Grease Zerk	2	
13	92470	Castle Nut 2-12UNF Grade 5	2	
14	92472	Spindle Washer, Hardened	2	
15	92545	Inner Bearing Cone	2	Ref #HM218248
16	9390-026	Capscrew 5/16-18UNC x 1/2 Grade 5	8	
17	9390-064	Capscrew, 3/8-16UNC x 3 1/4 Grade 5	2	
18	284230	Gasket	2	
19A	9004903	Load Cell - Scale 2.875" Dia.	4	
19B	268289	Bar - Non-Scale 2 7/8 Dia x 18	4	
20	91192	Retaining Ring 1"	8	
21	92199	Center Locknut, 1-8UNC	4	
22	9390-138	Capscrew, 5/8-11UNC x 7 Grade 5	2	
23	91299-1457	Capscrew 1-14UNS x 3 1/4 Grade 8	12	
24	9390-193	Capscrew, 1-8UNC x 5 Grade 5	4	
25	9008440	Center Locknut, 5/8-11UNC Grade 8	2	
26	97319	Flange Nut, M22x1.5	20	
27	902875	Locknut, 3/8-16UNC	2	
28	272754G	Runner Support Weldment =Green=	1	
	272754R	Runner Support Weldment =Red=		
29	288789B	Spacer Bushing	2	
30	804685	Washer 2"	32	
31	91299-1461	Capscrew 1-14UNS x 4 1/2 Grade 8	4	
32	9008441	Elastic Locknut, 1-14UNS Grade 8	16	

Brent 1196/1396 Right-Hand Unload — Parts

Axle & Hub Components - Model 1396 Single Wheels

Please visit www.unverferth.com/parts/ for the most current parts listing.

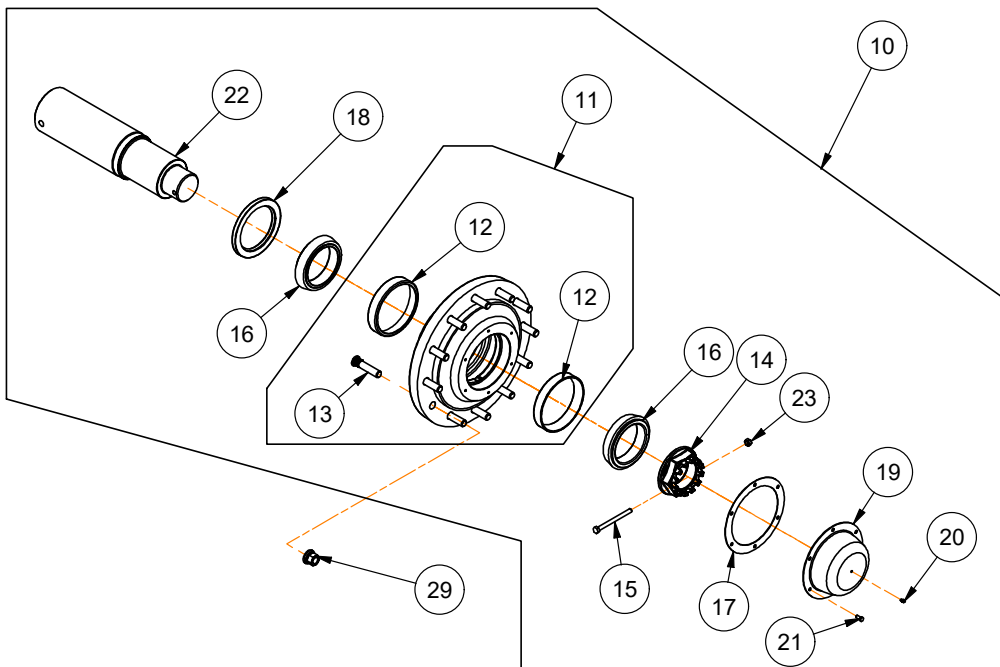
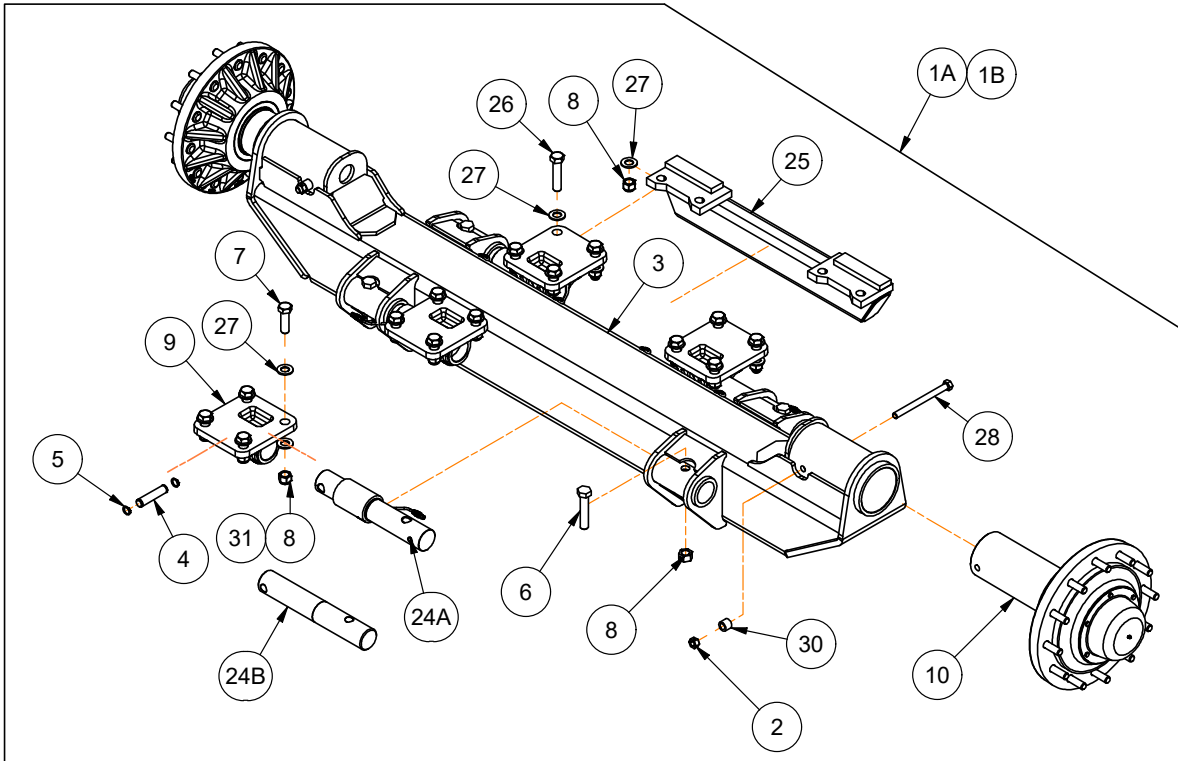

Brent 1196/1396 Right-Hand Unload — Parts

Axle & Hub Components - Model 1396 Single Wheels

Please visit www.unverferth.com/parts/ for the most current parts listing.

ITEM	PART NO.	DESCRIPTION	QTY	NOTES	
1A	271630G	Axle Bundle 119" w/Scale Spindles =Green=	1	For Scale Units	
	271630R	Axle Bundle 119" w/Scale Spindles =Red=			
1B	271631G	Axle Bundle 119" for Non-Scale Spindles =Green=		1	For Non-Scale Units
	271631R	Axle Bundle 119" for Non-Scale Spindles =Red=			
2	9008442	Center Locknut, 3/4-10UNC Grade 8	2		
3	271628G	Axle Weldment =Green=	1	For 6" Spindle	
	271628R	Axle Weldment =Red=			
4	250843	Scale Hitch Pin, 1" Dia x 4 9/16	4		
5	91192	Retaining Ring 1"	8		
6	9390-193	Capscrew, 1-8UNC x 5 Grade 5	4		
7	91299-1457	Capscrew, 1-14UNS x 3 1/4 Grade 8	12		
8	92199	Center Locknut, 1-8UNC	4		
9	268836G	Axle Mount Weldment =Green=	4		
	268836R	Axle Mount Weldment =Red=			
10	282310G	Hub & Spindle Assembly =Green=	2	Includes Items: 11, 14, 15, 16, 17, 18, 19, 20, 21, 23	
	282310R	Hub & Spindle Assembly =Red=			
	272926G	12 Bolt Hub Assembly less Spindle =Green=	2		
	272926R	12 Bolt Hub Assembly less Spindle =Red=			
11	282312G	12 Bolt Hub Sub-Assembly =Green=	2	Model 881 Hub	
	282312R	12 Bolt Hub Sub-Assembly =Red=			
12	9006996	Bearing Cup 7.5" DIA. x 1.3125	8	Ref #48320	
13	9007001	Stud, M22x1.5 x 4	24		
14	282316	Spindle Nut	2		
15	9007854	Capscrew, 1/2-13UNC x 5 3/4 Gr.5	2		
16	9007007	Bearing Cone	2	Ref #48385	
17	282315	Gasket	2		
18	9007010	Seal	2		
19	282314G	Hub Cap "Bolt-On Type" =Green=	2		
	282314R	Hub Cap "Bolt-On Type" =Red=			
20	91160	Grease Zerk	4		
21	9390-028	Capscrew 5/16-18UNC x 3/4 Grade 5	12		
22	282311	Spindle 6" Dia. x 23 3/4	2		
23	94981	Locknut, 1/2-13UNC	2		
24A	9004903	Load Cell - Scale 2.875" Dia.	4		
24B	268289	Bar - Non-Scale 2 7/8 Dia x 18	4		
25	272754G	Runner Support Weldment =Green=	1		
	272754R	Runner Support Weldment =Red=			
26	91299-1461	Capscrew, 1-14UNS x 4 1/2 Gr.8	4		
27	804685	Washer 2"	32		
28	91299-256	Capscrew 3/4-10UNC x 9 Grade 8	2		
29	97319	Flange Nut, M22x1.5	24		
30	283895B	Spacer Bushing	2		
31	9008441	Elastic Locknut, 1-14UNS Grade 8	16		

Brent 1196/1396 Right-Hand Unload — Parts

Hopper Components

Please visit www.unverferth.com/parts/ for the most current parts listing.

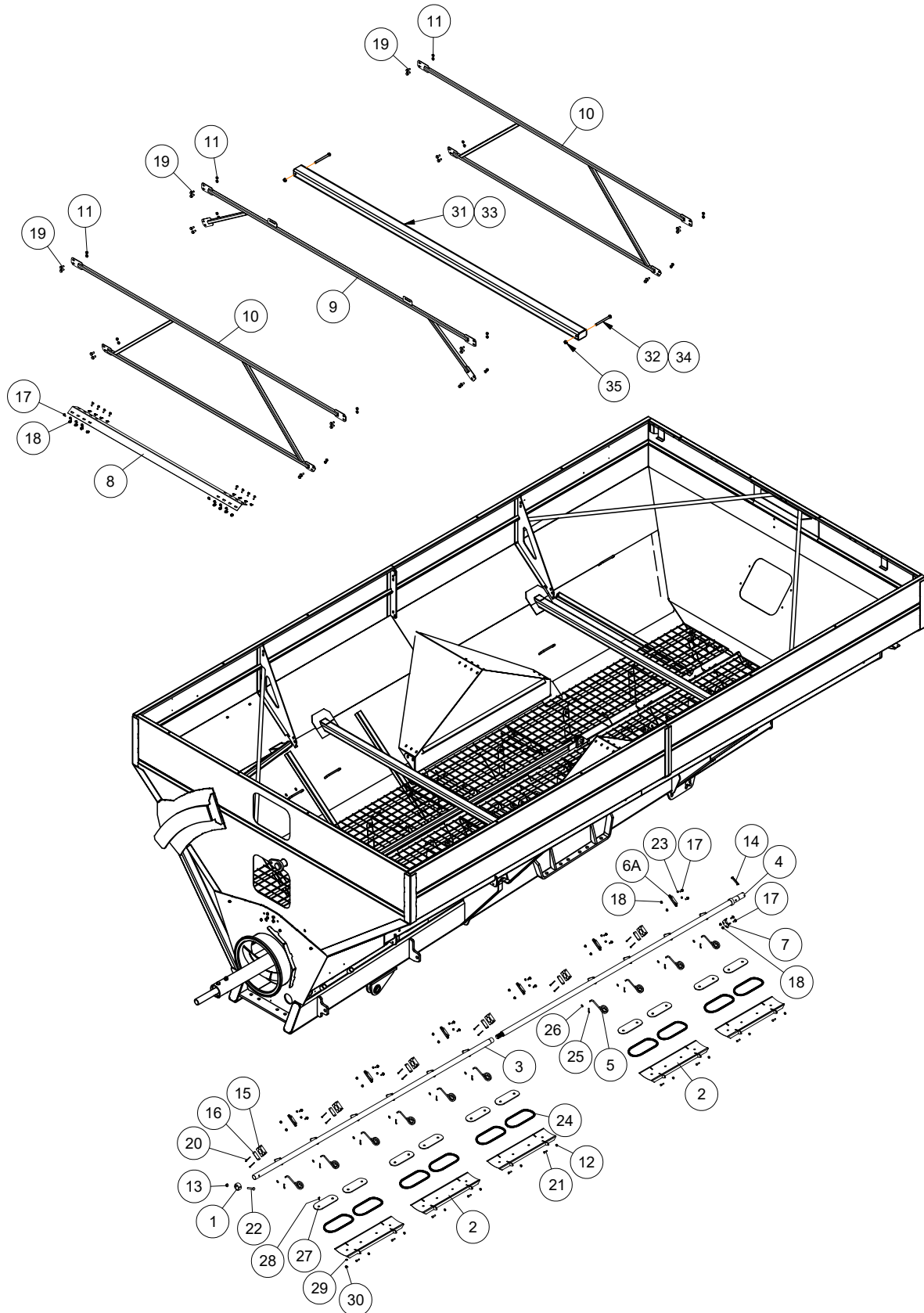

Brent 1196/1396 Right-Hand Unload — Parts

Hopper Components

Please visit www.unverferth.com/parts/ for the most current parts listing.

ITEM	PART NO.	DESCRIPTION	QTY	NOTES
1	271566B	Stop Bushing =Black=	1	
2	271664B	Cleanout Door Weldment =Black=	6	(Walking Tandem)
			5	(Single Axle & Tracks)
3	271700B	Front Link Arm Weldment =Black=	1	
4	271568B	Rear Link Arm Weldment =Black=	1	(Walking Tandem)
	271702B	Rear Link Arm Weldment =Black=	1	(Single Axle)
5	286417	Door Link Spring =Black=	12	(Walking Tandem)
		Door Link Spring =Black=	10	(Single Axle & Tracks)
6A	286414B	Pivot Door =Black=	6	
7	273753B	Door Latch Weldment =Black=	1	
8	284401B	Wheel Well Brace Plate =Black=	1	(Walking Tandem) - Not Used on Tracks
	283444B	Wheel Well Brace Plate =Black=	1	(Single Axle)
9	284435B	Cross Tube Weldment =Black=	1	Model 1196
	284392B	Cross Tube Weldment =Black=	1	Model 1396
10	284407B	Cross Tube Weldment (Inside) =Black=	2	Model 1196
	284393B	Cross Tube Weldment (Inside) =Black=	2	Model 1396
11	9002058	Center Lock Flange Nut, 1/2-13UNC Grade 5	24	
12	9003396	Locknut, 3/8-16UNC Grade 5	10	
13	9003397	Locking Flange Nut, 1/2-13UNC Grade 5	1	
14	9005305	Lynch Pin, 3/8" Dia. x 3	1	
15	9006351	Clamp	6	
16	9006352	Top Plate	6	
17	91262	Large Flange Screw, 3/8-16UNC x 1 Grade 5	30	
18	91263	Large Flange Nut, 3/8-16UNC Grade 5	30	
19	91266	Flange Screw, 1/2-13UNC x 1 1/4 Grade 5	24	
20	9390-015	Capscrew, 1/4-20UNC x 3 1/2 Grade 5	12	
21	9390-056	Capscrew, 3/8-16UNC x 1 1/4 Grade 5	10	
22	9390-108	Capscrew, 1/2-13UNC x 3 1/4 Grade 5	1	
23	97189	Large Flange Hex Nut, 1/4-20UNC Grade 5	12	
24	9007108	Gasket	26 Ft.	(Single Axle, Tracks)
			32 Ft.	(Walking Tandem)
25	TA8B95	Cotter Pin, 1/8 Dia. x 1 15/16	10	(Single Axle, Tracks)
			12	(Walking Tandem)
26	9405-076	Flat Washer, 3/8	10	
27	286418B	Cleanout Door Doubler Plate =Black=	10	(Single Axle, Tracks)
			12	(Walking Tandem)
28	903171-660	Flat Head Phillips Screw, 5/16-18UNC x 1	20	(Single Axle, Tracks)
			24	(Walking Tandem)
29	9405-070	Flat Washer, 5/16 USS	20	(Single Axle, Tracks)
			24	(Walking Tandem)
30	91257	Large Flange Hex Nut, 5/16-18 UNC	20	(Single Axle, Tracks)
			24	(Walking Tandem)
31	295870B	Middle Cross Tube Weldment =Black=	1	For SN B42340100 & Higher
32	9390-113	Capscrew, 1/2"-13UNC x 5" Grade 5	2	(Tracks Only)
33	281796B	Cross Tube Weldment =Black=	1	For SN B42340099 & Lower
34	9390-114	Capscrew, 1/2"-13UNC x 5 1/2" Grade 5	2	(Tracks Only)
35	9800	Locknut, 1/2"-13UNC	2	(Tracks Only)

Brent 1196/1396 Right-Hand Unload — Parts

Walking Tandem Assembly Components

Please visit www.unverferth.com/parts/ for the most current parts listing.

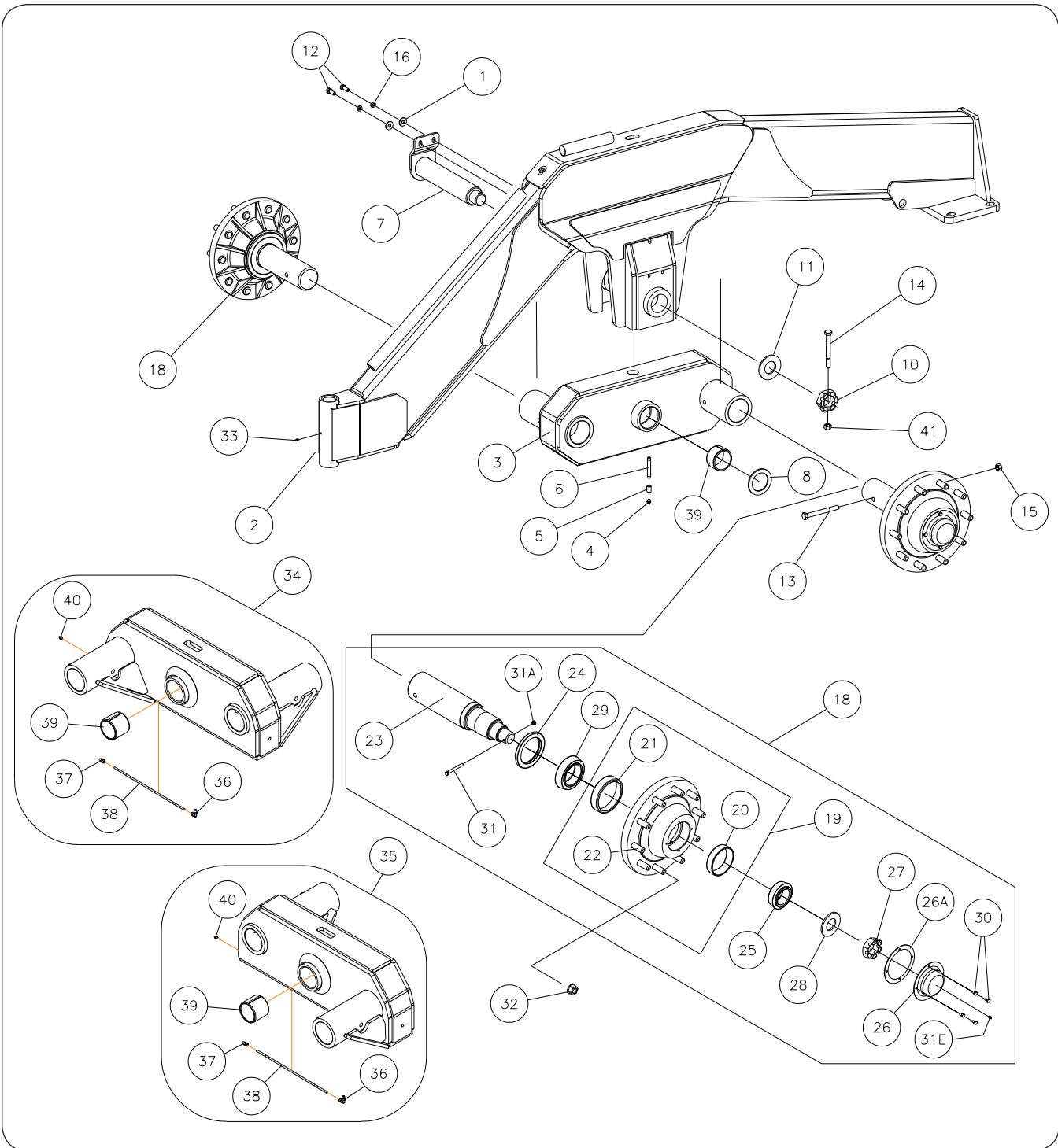

Brent 1196/1396 Right-Hand Unload — Parts

Walking Tandem Assembly Components

Please visit www.unverferth.com/parts/ for the most current parts listing.

ITEM	PART NO.	DESCRIPTION	QTY	NOTES
1	9405-088	Flat Washer 1/2"	4	
2	282882G	Walking Tandem Weldment =Green=	2	
	282882R	Walking Tandem Weldment =Red=		
3	282794B	Axle Weldment RH (Shown)	1	
	282793B	Axle Weldment LH	1	
4	93426	Grease Zerk	2	
5	9002538	Coupling-Pipe 1/8NPT	2	
6	9005414	Pipe Nipple 1/8-27NPT Threaded Ends	2	
7	282842	Axle Pin Weldment	2	
8	9001297	Flat Washer, 3"	4	
10	92470	Castle Nut, 2-12UNF Grade 5	2	
11	92472	Spindle Washer	2	
12	9390-100	Capscrew, 1/2-13UNC x 1 1/4 Grade 5	4	
13	9390-136	Capscrew, 5/8-11UNC x 6 Grade 5	4	
14	9390-065	Capscrew, 3/8-16UNC x 3 1/2" Grade 5	2	
15	95905	LockNut, 5/8-11UNC	4	
16	9404-025	Lock Washer, 1/2"	4	
17	267276G	Hub & Spindle Kit =Green=	1	Includes Item 18 & 32
	267276R	Hub & Spindle Kit =Red=		
18	266520G	Hub & Spindle Assembly =Green=	4	Includes Items 17-29
	266520R	Hub & Spindle Assembly =Red=		
19	265390G	Hub Sub-Assembly =Green=	2	Model 881 Hub Includes Items 20-22
	265390R	Hub Sub-Assembly =Red=		
20	92462	Outer Bearing Cup	2	Ref. #HM212011
21	92476	Inner Bearing Cup	2	Ref. #HM218210
22	9007001	Stud Bolt, M22 x 1.5 x 4	20	
23	266521	Complete Spindle Asy, 3 3/4" Dia.	2	Includes Items 27, 28, 31
24	92565	Seal	2	Ref. #37605SA
25	92464	Outer Bearing Cone	2	Ref. #HM212049
26	286171G	Hub Cap "Bolt-On Type" =Green=	2	
	286171R	Hub Cap "Bolt-On Type" =Red=		
26A	284230	Gasket	2	
27	92470	Castle Nut, 2-12UNF Grade 5	2	
28	92472	Spindle Washer, Hardened	2	
29	92545	Inner Bearing Cone	2	Ref. #HM218248
30	9390-026	Capscrew, 5/16-18UNC x 1/2 Grade 5	8	
31	9390-064	Capscrew, 3/8-16UNC x 3 1/4 Grade 5	2	
31A	902875	Locknut, 3/8-16UNC	2	
31E	91160	Grease Zerk	2	
32	267275	Wheel Nut Kit, M22 x 1.5 Threaded	1	
32A	97319	Flanged Cap Nut, M22 x 1.5 Grade 10	10	
32B	267288	Wheel Stud Replacement Kit - M22	1	Used to Replace 7/8" Cap- screw & Nut used on Hub (NOT SHOWN)
32C	9007001	Stud Bolt, M22 x 1.5 x 4	1	
32D	97319	Flanged Cap Nut, M22 x 1.5 Grade 10	1	
33	91160	Grease Zerk	2	
34	282784B	Axle Assembly, Left-Hand For 650/65R42 WH/TI	1	Includes: 36 thru 40
	282788B	Axle Assembly, Left-Hand For All WH/TI except 650/65R42		
35	282785B	Axle Assembly, Right-Hand For 650/65R42 WH/TI	1	Includes: 36 thru 40
	282789B	Axle Assembly, Right-Hand For All WH/TI except 650/65R42		
36	9005072	Quicklinc Fitting, 90° Swivel	1	
37	9005073	Quicklinc Fitting, Straight	1	
38	9005074	Tube	1	
39	9005474	Tension Bushing	4	
40	93426	Grease Zerk	1	
41	9928	Locknut 3/8-16UNC Grade 5	2	

Walking Tandem Mounting Components

Please visit www.unverferth.com/parts/ for the most current parts listing.

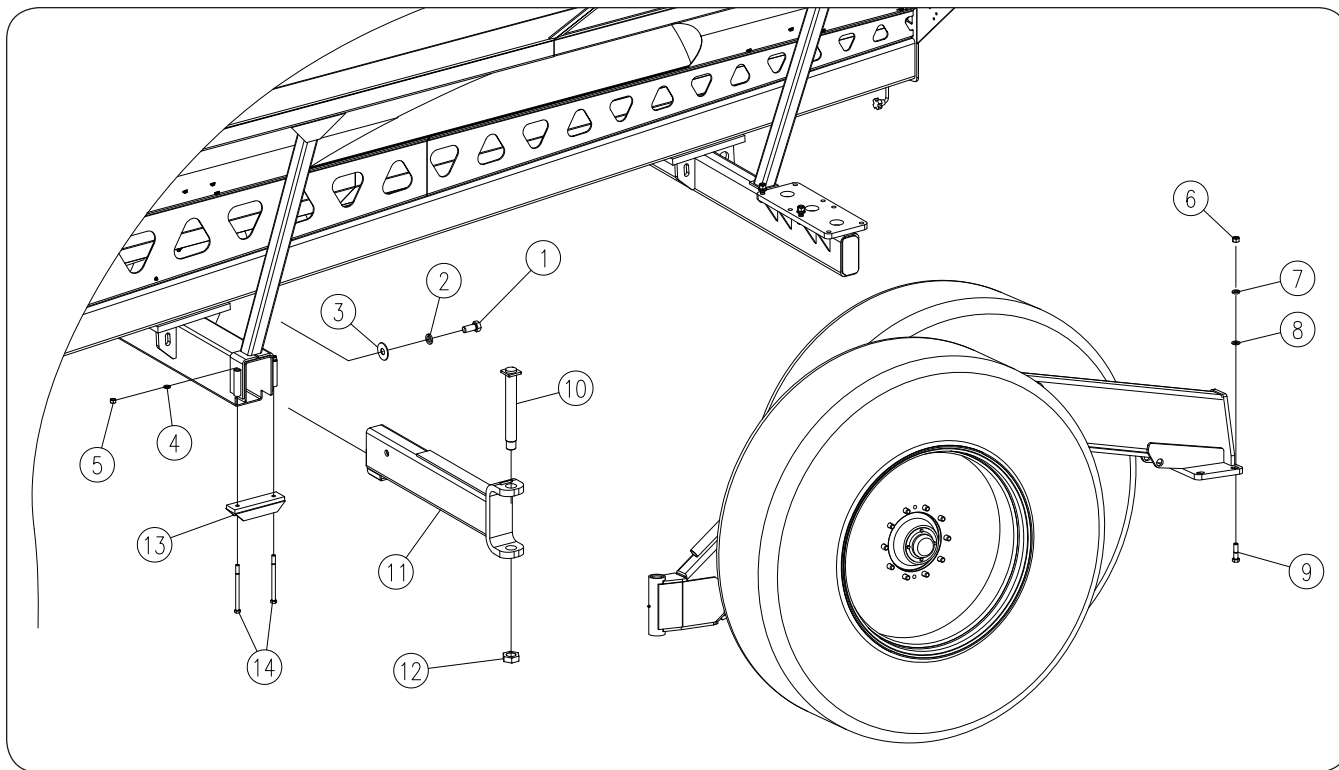

ITEM	PART NO.	DESCRIPTION	QTY	NOTES
1	9390-422	Capscrew 1 1/8-7UNC x 2 1/2 Grade 5	2	
2	9404-045	Lock Washer 1 1/8	2	
3	9405-126	Flat Washer 1 1/8	2	
4	9404-030	Lock Washer 5/8	4	
5	9394-014	Hex Nut 5/8-11UNC Grade 5	4	
6	9394-020	Hex Nut 1-8UNC Grade 5	8	
7	9404-042	Lock Washer 1"	8	
8	804685	Flat Washer Hardened	8	
9	9390-189	Capscrew 1-8UNC x 3 1/2 Grade 5	8	
10	268521	Axle Pivot Pin Weldment	2	
11	282815G	Axle Extension Weldment =Green=	2	
	282815R	Axle Extension Weldment =Red=		
12	9002029	Lock Jam Nut 1 3/4-5UNC	2	
13	284185G	Clamp Weldment =Green=	2	
	284185R	Clamp Weldment =Red=		
14	9390-442	Capscrew 5/8-11UNC x 9 Grade 5	4	

Wheels & Tires

Please visit www.unverferth.com/parts/ for the most current parts listing.

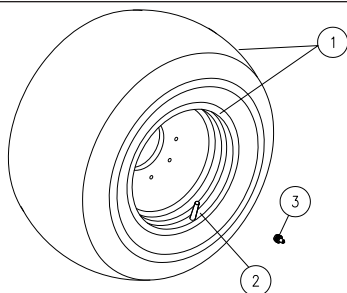

TIRES

For questions regarding new tire warranty, please contact your local original equipment tire dealer. Used tires carry no warranty. Tire manufacturers' phone numbers and websites are listed in Maintenance Section for your convenience.

ITEM	PART NO.		DESCRIPTION	QTY	NOTES
	OFF-WHITE	SILVER MIST			
1	110825WO/99478	110825SM/99478	Wheel & Tire Asy (10 Bolt)	2	36 x 32 / 1050/50R32 R-1W
	110825WO	110825SM	Wheel Only	2	36 x 32
2	93300	93300	Valve Stem	2	
	95365	95365	Plug	2	
1	16768	-	Wheel & Tire Asy (10 Bolt)	2	44 x 32/76x50-32 HF-3 (16-Ply)
	17844	17844SM	Wheel & Tire Asy (10 Bolt)	2	44 x 32/76x50-32 HF-3 (20-Ply)
	12870	12870SM	Wheel Only (10 Bolt)	2	RDT4432
2	95854WO	95854SM	Side Flange	2	
	96727	96727	Valve Stem	2	
	92315WO	92315SM	Lock Ring	2	
	92316	92316	O-Ring	2	
	901207	901207	Valve Stem Adapter	-	
1	17939WO/9500848	17939SM/9500848	Wheel & Tire Assembly (10 Bolt)	2	30 x 32 / 35.5LR32 R-3
	110803WO/9500992	110803SM/9500992	Wheel & Tire Assembly (10 Bolt)	2	44 x 32 / 1250/50R32 R-1W
	110803WO/9500943	110803SM/9500943	Wheel & Tire Assembly (10 Bolt)	2	44 x 32 / 1250/50R32
	110598WO/9500943	110598SM/9500943	Wheel & Tire Assembly (12 Bolt)	2	Model 1396 Only 44 x 32/1250/50R32 R-1W
1	110803WO/9501414	110803SM/9501414	Wheel & Tire Assembly (10 Bolt)	2	44x32/IF1250/50R32 CFO R-1W
	110803WO	110803SM	Wheel Only	2	44 x 32
1	17939WO	17939SM	Wheel Only	2	30 x 32
1	110598WO	110598SM	Wheel Only (12 Bolt)	2	Model 1396 Only 44 x 32

Dual Wheels & Tires

Please visit www.unverferth.com/parts/ for the most current parts listing.

ITEM	PART NO.		DESCRIPTION	QTY	NOTES
	OFF-WHITE	SILVER MIST			
1	-	14680SM	Wheel & Tire Assembly - 1/2" Inset	4	18 x 38 / 520/85R38 R-1
	-	14678SM	Wheel Only	4	18 x 38
1	-	17418SM	Wheel & Tire Assembly - 1/2" Inset	4	18 x 38 / 520/85x38 R-1
	17704WO	17704SM	Wheel Only	4	18 x 38
1	-	18739SM	Wheel & Tire Assembly - 1/2" Inset	4	18 x 42 / TL520/85R42F R-1
	-	18624SM/9501911	Wheel & Tire Assembly	4	18 x 42 / IF520/85R42CFO R-1W
	18624WO	18624SM	Wheel Only	4	18 x 42
1	-	18051SM	Wheel & Tire Assembly	4	20 x 42 / 650/65R42 R1W
	17877WO	17877SM	Wheel Only	4	20 x 42
2	93300	93300	Valve Stem	4	
	901207	901207	Valve Stem Adapter	-	

Brent 1196/1396 Right-Hand Unload — Parts

Track Axle Components
Models 1196 & 1396 with 36x148, 42x131, 42x148 & 50x148 Tracks
Please visit www.unverferth.com/parts/ for the most current parts listing.

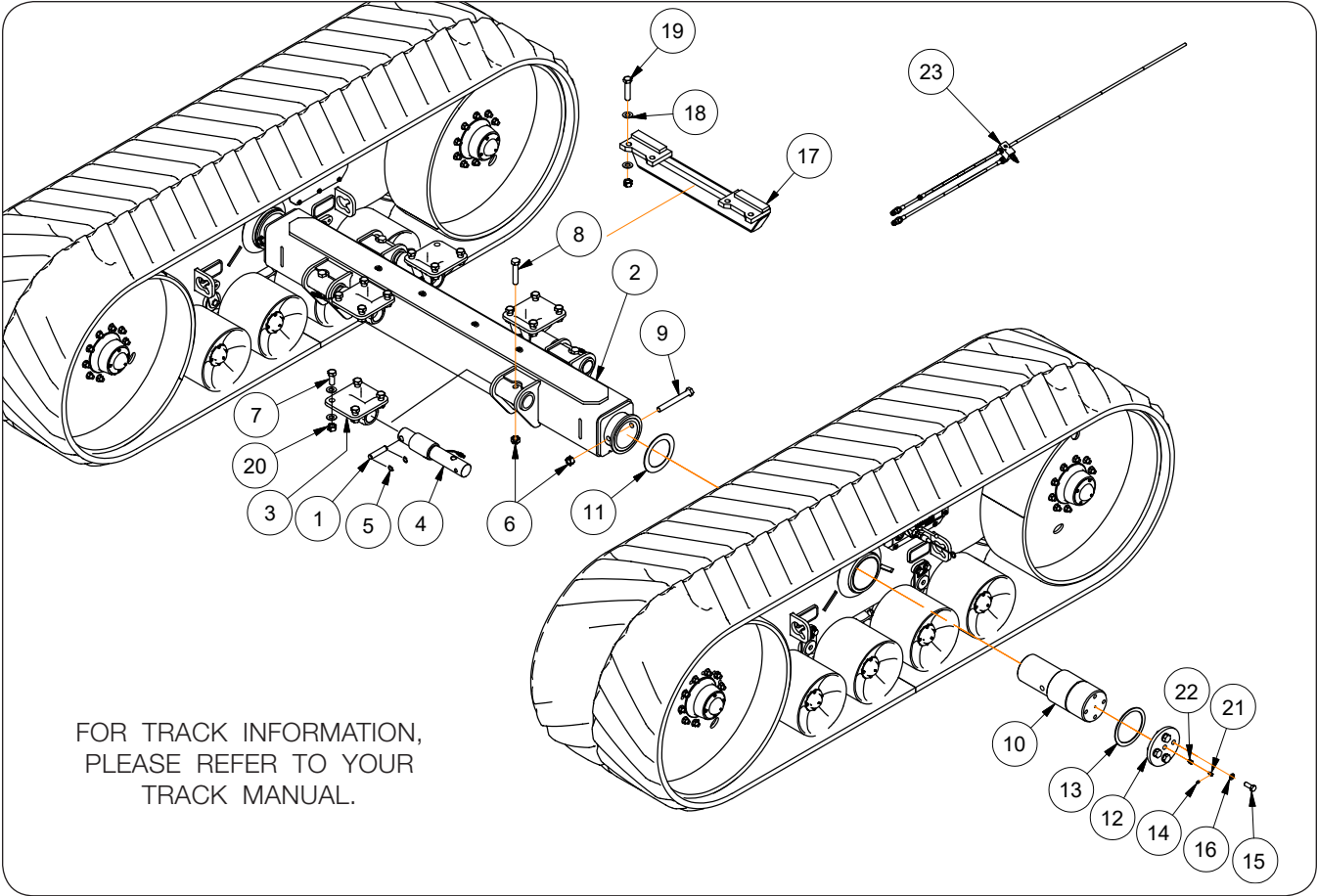

Brent 1196/1396 Right-Hand Unload — Parts

Track Axle Components

Models 1196 & 1396 with 36x148, 42x131, 42x148 & 50x148 Tracks

Please visit www.unverferth.com/parts/ for the most current parts listing.

ITEM	PART NO.	DESCRIPTION	QTY	NOTES
1	250843	Pin 1" Dia. x 4 9/16	4	
2	268764B	Axle Weldment =Black=	1	(Standard Tracks 36x148 & Equalizer Tracks 50x148) (Long Axle Option for Equalizer Tracks 42x131 & 42x148)
	282054B	Axle Weldment =Black=	1	Short Axle Option for Equalizer Tracks 42x131 & 42x148
3	268836B	Axle Mount Weldment =Black=	4	
4	9004903	Load Bar, 2.875" Dia.	4	With Scales
	268289	Hitch Bar, 2.875" Dia.		Without Scales
5	91192	Retaining Ring 1"	8	
6	92199	Locknut, 1-8UNC	6	
7	91299-1457	Capscrew 1-14UNS x 3 1/4 Grade 8	12	
8	9390-193	Capscrew 1-8UNC x 5 Grade 5	4	
9	9390-462	Capscrew 1-8UNC x 8 1/2 Grade 5	2	
10	282395	Track Pivot Shaft 7" Dia. x 19 3/16	2	Standard Tracks Only
	282026	Track Pivot Shaft 7" Dia. x 19 1/8		Equalizer Tracks Only
11	282397	Washer 8 1/2" Dia.	2	
12	282689B	Cover Plate =Black=	2	
13	282690	Washer, 8 1/2" Dia.	2	
14	93426	Grease Zerk	2	
15	9390-184	Capscrew 1-8UNC x 2 1/4 Grade 5	8	
16	9404-041	Lockwasher 1"	8	
17	272754G	Runner Support Weldment =Green=	1	
	272754R	Runner Support Weldment =Red=		
18	804685	Washer 2"	32	
19	91299-1461	Capscrew 1-14UNS x 4 1/2 Grade 8	4	
20	9008441	Elastic Locknut, 1-14UNS Grade 8	16	
21	9006785	90° Adapter 1/8"NPT	1	
22	9006816	Adapter 1/8"NPT	1	
23	268063	Tensioner Hose Assembly	1	

Brent 1196/1396 Right-Hand Unload — Parts

Track Axle Components

Model 1196 with 36x112 & 36x131 Standard Tracks

Please visit www.unverferth.com/parts/ for the most current parts listing.

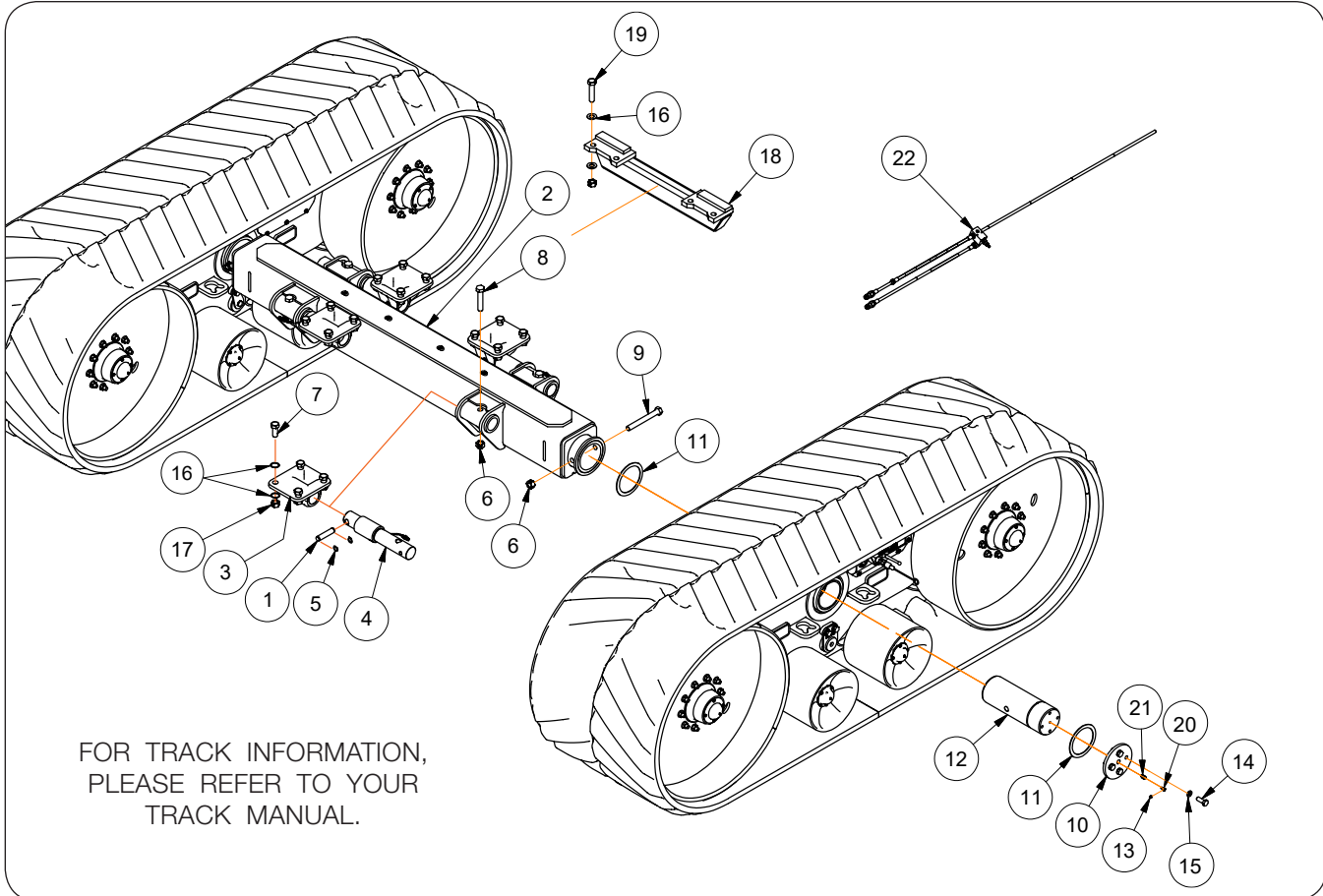

FOR TRACK INFORMATION,
PLEASE REFER TO YOUR
TRACK MANUAL.

ITEM	PART NO.	DESCRIPTION	QTY	NOTES
1	250843	Pin 1" Dia. x 4 9/16	4	
2	268764B	Axle Weldment =Black=	1	
3	268836B	Axle Mount Weldment =Black=	4	
4	9004903	Load Bar, 2.875" Dia.	4	With Scales
	268289	Hitch Bar, 2.875" Dia.		Without Scales
5	91192	Retaining Ring 1"	8	
6	92199	Locknut, 1-8UNC	6	
7	91299-1457	Capscrew 1-14UNS x 3 1/4 Grade 8	12	
8	9390-193	Capscrew 1-8UNC x 5 Grade 5	4	
9	9390-462	Capscrew 1-8UNC x 8 1/2 Grade 5	2	
10	268121B	Cover Plate =Black=	2	
11	268619	Washer 7 1/2" OD	4	
	268640	Track Pivot Shaft 6" Dia. x 16 5/8		36" x 131"
12	267124	Track Pivot Shaft 6" Dia. x 18 3/8	2	36" x 112"
	93426	Grease Zerk		2
13	93426	Grease Zerk	2	
14	9390-145	Capscrew 3/4-10UNC x 2 Grade 5	8	
15	9404-033	Lockwasher 3/4	8	
16	804685	Washer 2" OD	32	
17	9008441	Elastic Locknut, 1-14UNS Grade 8	16	
18	272754G	Runner Support Weldment =Green=	1	
	272754R	Runner Support Weldment =Red=		
19	91299-1461	Capscrew 1-14UNS x 4 1/2 Grade 8	4	
20	9006785	90° Adapter 1/8"NPT	1	
21	9006816	Adapter 1/8"NPT	1	
22	268063	Tensioner Hose Assembly	1	

Track Panel Kit Components

Please visit www.unverferth.com/parts/ for the most current parts listing.

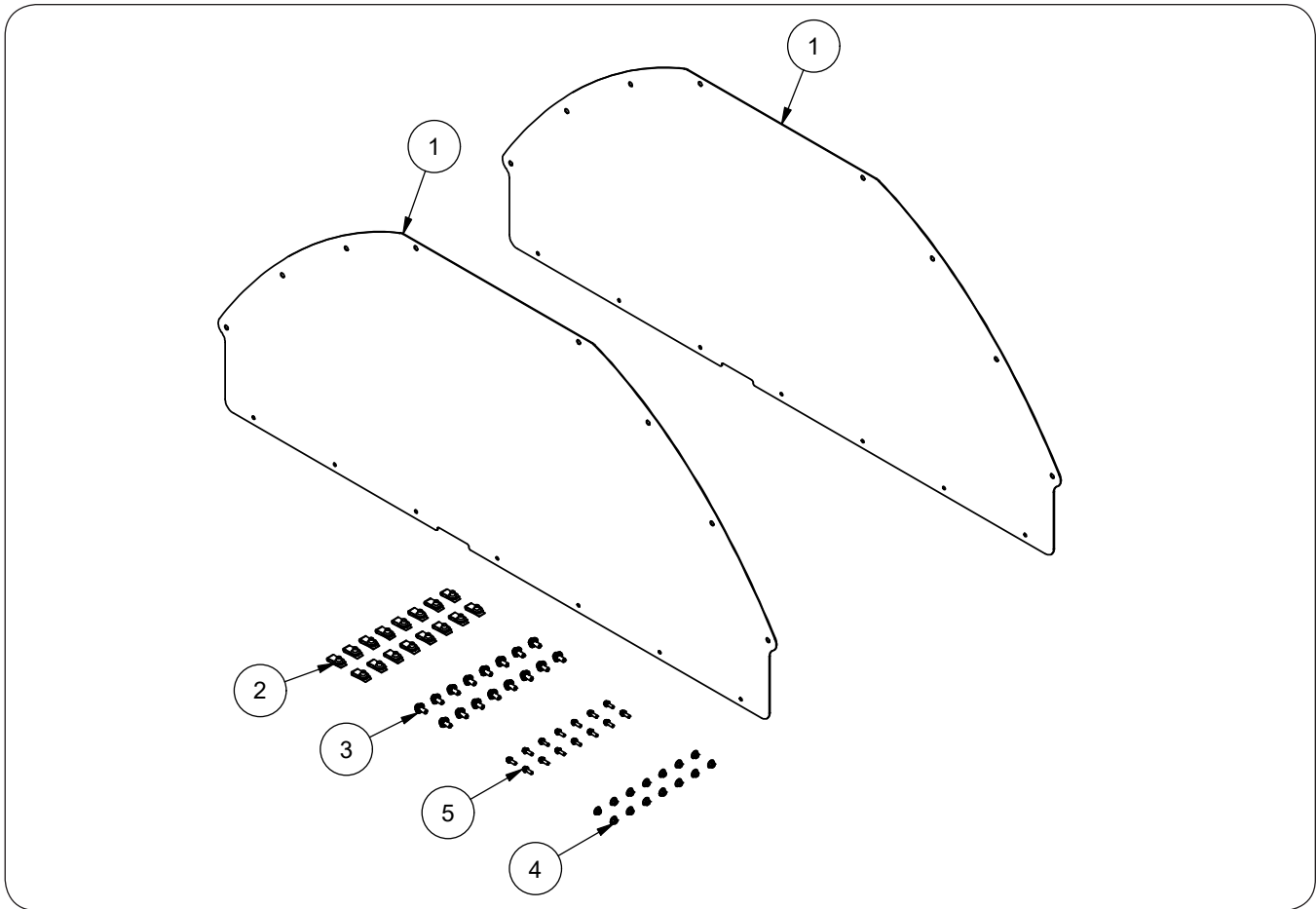

ITEM	PART NO.	DESCRIPTION	QTY	NOTES
	271374G	Track Panel Kit =Green=	-	Includes Items 1 through 5
	271374R	Track Panel Kit =Red=		
1	271373G	Track Panel Plate =Green=	2	
	271373R	Track Panel Plate =Red=		
2	9005376	U-nut, 3/8-16UNC	16	
3	95585	Capscrew, 3/8"-16UNC x 3/4" G5	16	
4	97189	Hex Nut, 1/4"-20UNC	14	
5	97420	Flange Screw, 1/4"-20UNC x 3/4" G5	14	

Brent 1196/1396 Right-Hand Unload — Parts

Sideboards - Model 1196

Please visit www.unverferth.com/parts/ for the most current parts listing.

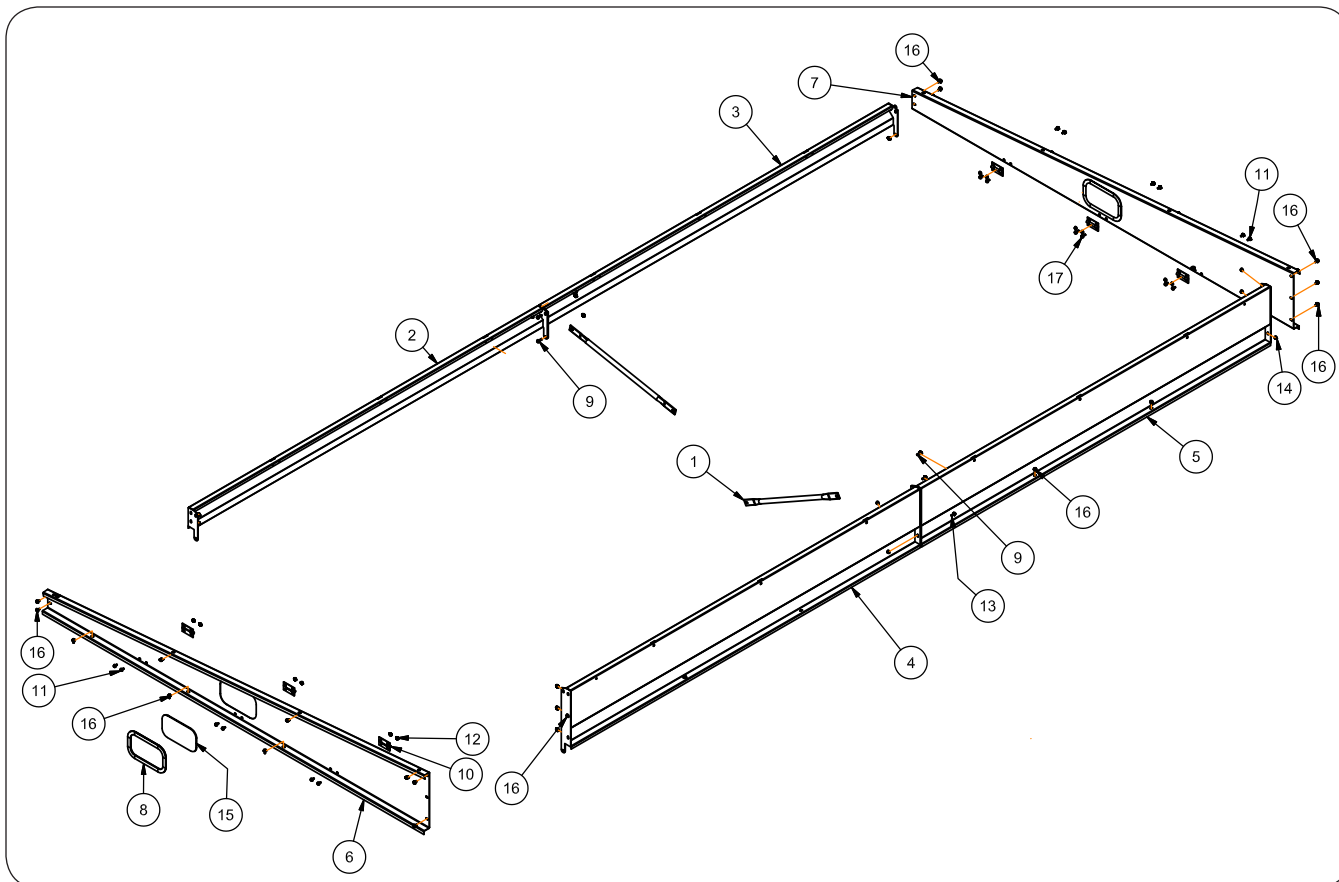

ITEM	PART NO.	DESCRIPTION	QTY	NOTES
1	220032B	Angle Brace Tube	2	
2	283550B	Board Weldment Front, Right-Hand	1	
3	283551B	Board Weldment Rear, Right-Hand	1	
4	283552B	Board Weldment Front, Left-Hand	1	
5	283553B	Board Weldment Rear, Left-Hand	1	
6	294110B	Board Front	1	
7	294111B	Board Rear	1	
8	250431	Window Moulding	2	
9	9003259	Flange Screw 3/8"-16UNC x 1 1/4"	6	
10	9004626	Hinge	6	
11	91256	Screw/Large Flange 5/16"-18UNC x 3/4" G5	24	
12	91257	Hex Nut/Large Flange 5/16"-18UNC G5	24	
13	91262	Screw/Large Flange 3/8"-16UNC x 1"	10	
14	91263	Hex Nut/Large Flange 3/8"-16UNC G5	62	
15	92403	Window (Clear Tempered)	1	
16	95585	Capscrew/Large Flange 3/8"-16UNC x 3/4" G5	33	
17	97604	Flange Screw 5/16"-18UNC x 1" G5	2	

Brent 1196/1396 Right-Hand Unload — Parts

Sideboards - Model 1396

Please visit www.unverferth.com/parts/ for the most current parts listing.

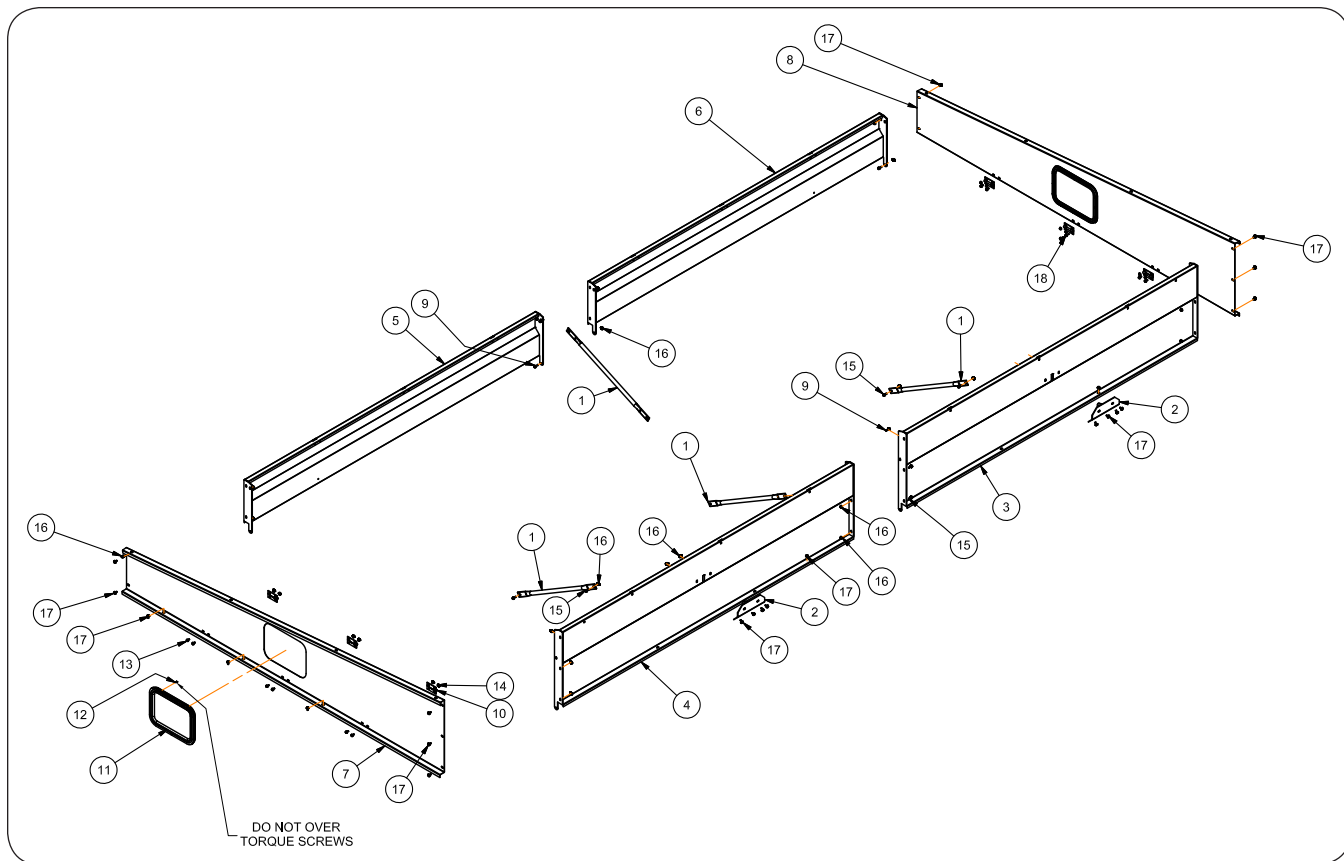

ITEM	PART NO.	DESCRIPTION	QTY	NOTES
1	220032B	Angle Brace Tube	4	
2	282319B	Brace Bracket Weldment	2	
3	283322B	Board Weldment Rear LH	1	
4	283324B	Board Weldment Front LH	1	
5	284361B	Board Weldment Front RH	1	
6	284362B	Board Weldment Rear RH	1	
7	294112B	Board Front	1	
8	294113B	Board Rear	1	
9	9003259	Flange Screw 3/8"-16UNC x 1 1/4"	6	
10	9004626	Hinge	6	
11	9008857	Window & Trim Assembly	2	
12	9008933	Pan Head Screw #8-18UNC x 1/2"	24	
13	91256	Screw/Large Flange, 5/16-18UNC x 3/4 Grade 5	24	
14	91257	Hex Nut/Large Flange, 5/16-18UNC Grade 5	24	
15	91262	Screw/Large Flange, 3/8-16UNC x 1	15	
16	91263	Hex Nut/Large Flange, 3/8-16UNC Grade 5	66	
17	95585	Capscrew/Large Flange, 3/8-16UNC x 3/4 Grade 5	41	
18	97604	Flange Screw 5/16-18UNC x 1 G5	2	

Horizontal Auger Components

Please visit www.unverferth.com/parts/ for the most current parts listing.

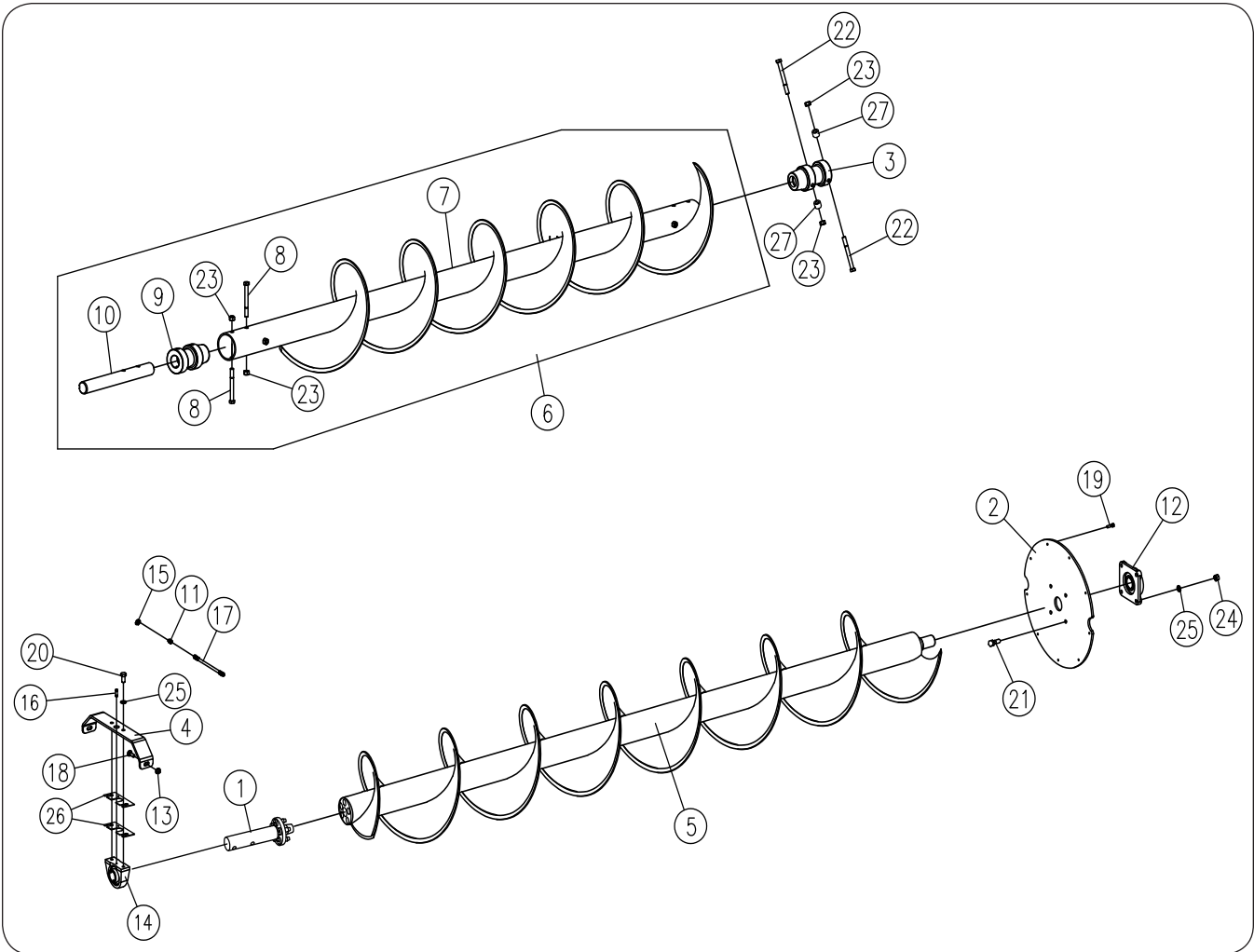

Horizontal Auger Components

Please visit www.unverferth.com/parts/ for the most current parts listing.

ITEM	PART NO.	DESCRIPTION	QTY	NOTES
1	293957	Auger Coupler Shaft Weldment	1	
2	283097G	Cover Plate =Green=	1	
	283097R	Cover Plate =Red=		
3	286282	Shaft Bushing Weldment	1	
4	286381B	Bearing Mounting Bar	1	
5	293954B	Rear Lower Auger Weldment =Black=	1	
6	294138B	Front Horizontal Auger Kit	1	Includes Items 7, 8, 9, 10, 23
7	294137B	Front Lower Auger Weldment =Black=	1	
8	91299-157	Capscrew, 3/4-10UNC x 6 Grade 8	2	
9	283535	Auger Tube Adapter	1	
10	283537	Auger Shaft	1	
11	9002479	Adapter 1/8-27 NPTF Male x 1/8-27 NPSM Female Swivel Nut	1	
12	9002492	Bearing/Flanged 2" Dia.	1	
13	91267	Locknut 1/2-13UNC	2	
14	9004731	Pillow Block Bearing	1	
15	9004764	90° Elbow 1/8 Female NPTF x 1/8 Female NPTF	1	
16	9006964	Nipple 1/8-27 NPT Male x 1/8-27 NPT Male	1	
17	9002689	Hose 1/8 x 12, 3000 PSI	1	
18	9388-104	Carriage Bolt 1/2-13UNC x 1 1/2 Grade 5	2	
19	91256	Capscrew 3/8-16UNC x 1 1/4 Grade 5	4	
20	9390-123	Capscrew 5/8-11UNC x 1 3/4 Grade 5	2	
21	9390-124	Capscrew 5/8-11UNC x 2 Grade 5	4	
22	9390-159	Capscrew, 3/4-10UNC x 7 Grade 5	2	
23	9802	Lock Nut, 3/4-10UNC	4	
24	9394-014	Hex Nut, 5/8-11UNC Grade 5	4	
25	9404-029	Lock Washer 5/8"	6	
26	286424B	Bearing Shim Plate =Black=	2	As Required
27	283895B	Spacer Bushing	2	

Vertical Auger Flighting Components

Please visit www.unverferth.com/parts/ for the most current parts listing.

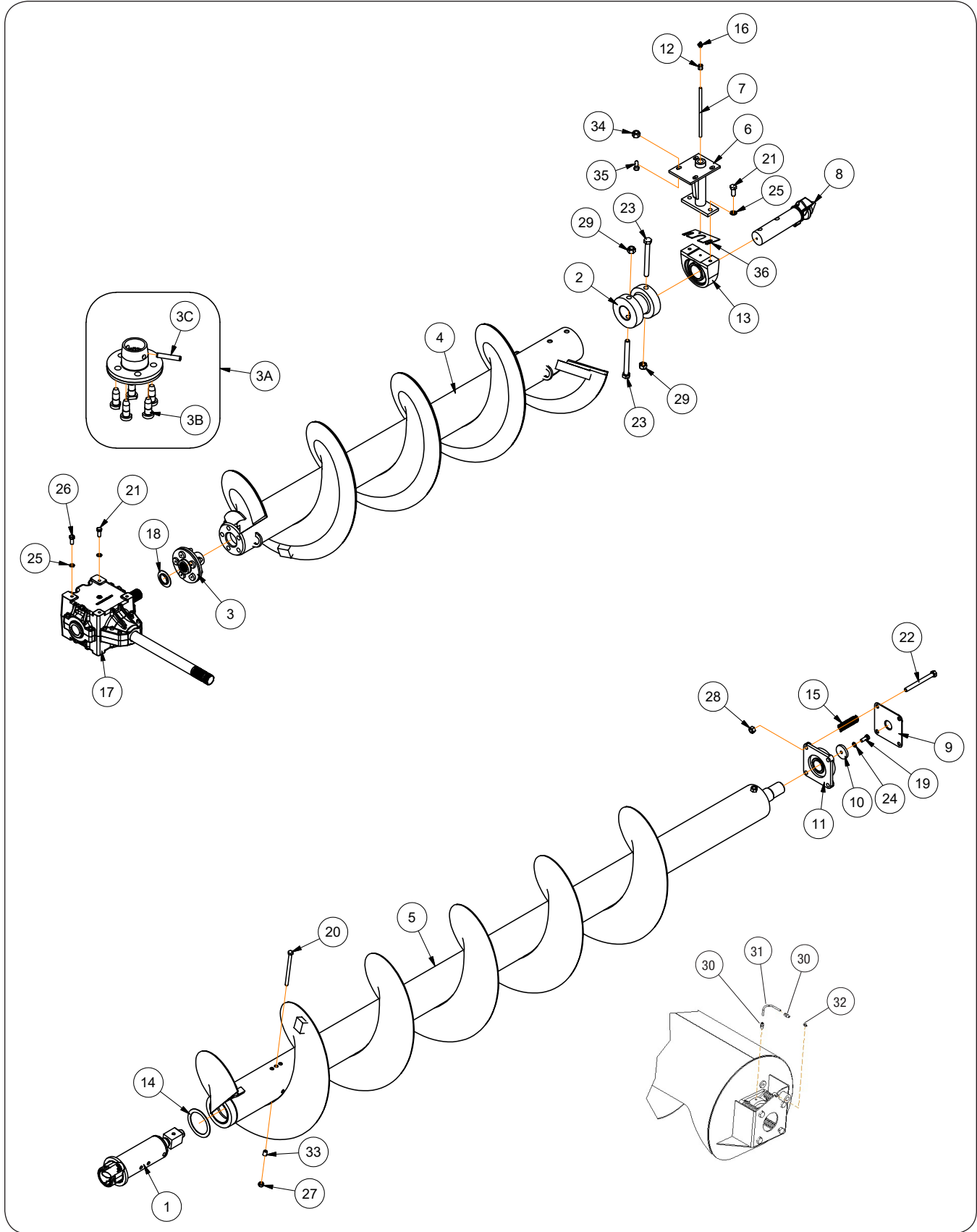

Brent 1196/1396 Right-Hand Unload — Parts

Vertical Auger Fighting Components

Please visit www.unverferth.com/parts/ for the most current parts listing.

ITEM	PART NO.	DESCRIPTION	QTY	NOTES
1	281283	Soft Start Assembly	1	
2	283515	Auger Tube Adapter	1	
3A	287802	Auger Drive Plate Assembly	1	
3B	9007000	Drive Head Pin	5	
3C	902614-238	Spiral Pin, 1/2" Dia. x 2 3/4"	1	
4	294131B	Lower Auger Replacement Kit	1	Includes Item 3A (287802) 5-Pin Driver
5	289850B	Upper Auger Weldment =Black=	1	
6	289898B	Bearing Bracket Replacement Kit =Black=	1	
7	284636	Grease Pipe	1	
8	288813	Drive Dog, Machined	1	
9	284986	Hood Pivot Pin Weldment	1	
10	407699	Washer Plate, 2 1/2" Dia.	1	
11	9002492	Bearing 2" Dia. Flanged	1	
12	9004764	90° Elbow, 1/8" NPTF Female	1	
13	9004731	Pillow Block Bearing, 2 1/2" Bore	1	
14	9004878	Self Lubricating Washer	1	
15	9004899	Spring - 10 Coils	4	
16	9000875	Grease Zerk	1	
17	9007366	Gearbox Assembly, 800 Series	1	
18	9007377B	Dust Cover =Black=	1	
19	9390-100	Capscrew, 1/2"-13UNC x 1 1/4" Grade 5	1	
20	9390-119	Capscrew, 1/2"-13UNC x 8"	1	Replacement Kit #293428 Includes Items: 20, 27, 33
21	9390-122	Capscrew, 5/8"-11UNC x 1 1/2"	4	Grade 5
22	9390-137	Capscrew, 5/8"-11UNC x 6 1/2"	4	Grade 5
23	9390-159	Capscrew, 3/4"-10UNC x 7"	2	Grade 5
24	9404-025	Lockwasher, 1/2" Grade 5	1	
25	9404-030	Lock Washer, 5/8"	10	
26	9390-124	Capscrew, 5/8"-11UNC x 2"	6	
27	9800	Locknut, 1/2"-13UNC	1	Grade 5
28	9801	Locknut, 5/8"-11UNC	4	Grade 5
29	9802	Locknut, 3/4"-10UNC	2	Grade 5
30	9005073	Quicklinc Fitting 1/4" Tube x 1/8" NPT	2	
31	9005074	Tube 1/4" OD	1	
32	93426	Grease Zerk	1	
33	410511	Spacer Bushing	1	
34	9003397	Lock Nut/Top, 1/2"-13UNC	4	
35	9388-104	Carriage Bolt, 1/2"-13UNC x 1 1/2" G5	4	
36	286419B	Bearing Shim Plate =Black=	1	

Lower Auger Door & Cover Components

Please visit www.unverferth.com/parts/ for the most current parts listing.

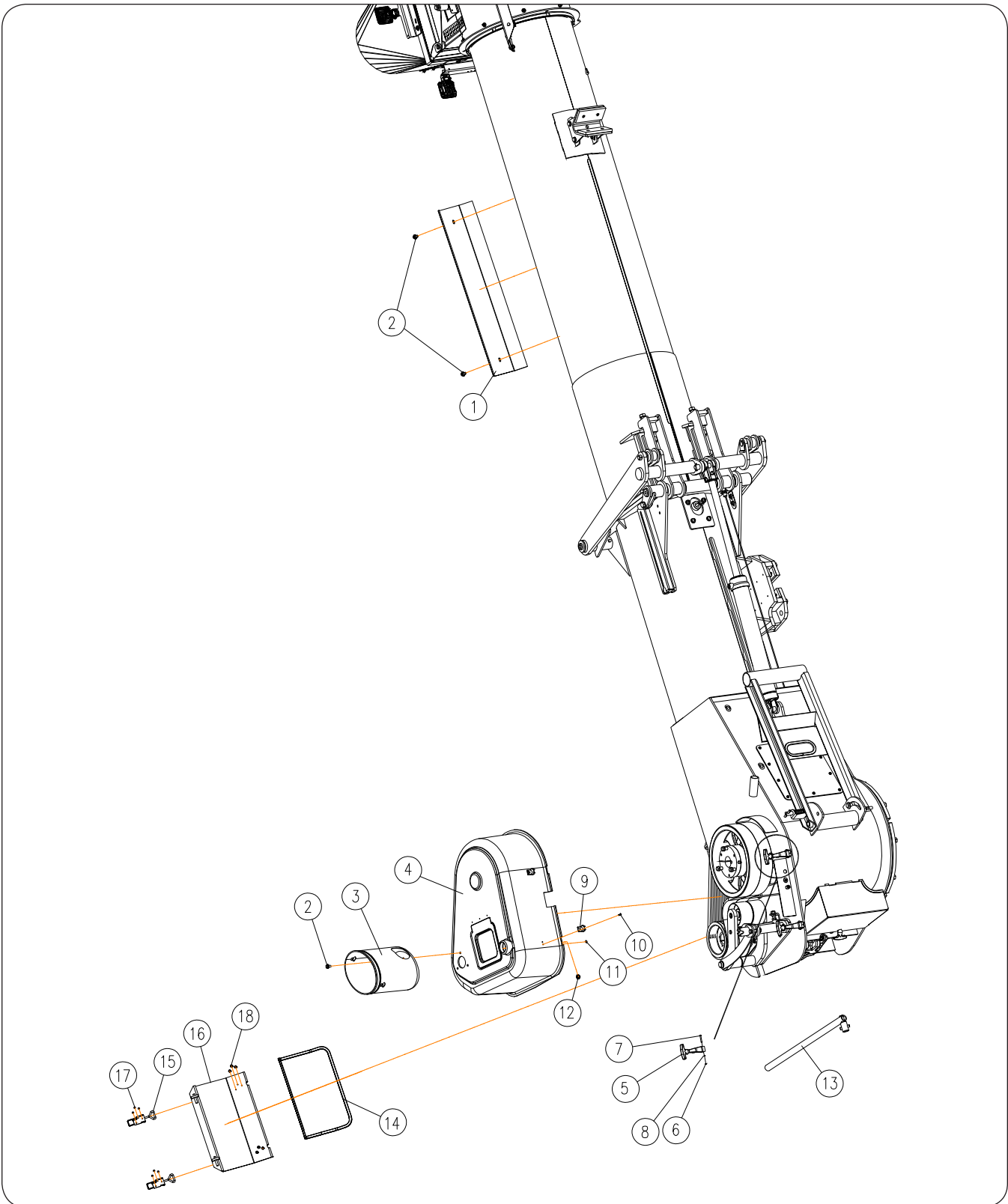

Brent 1196/1396 Right-Hand Unload — Parts

Lower Auger Door & Cover Components

Please visit www.unverferth.com/parts/ for the most current parts listing.

ITEM	PART NO.	DESCRIPTION	QTY	NOTES
1	284141G	Strike Plate =Green=	1	
	284141R	Strike Plate =Red=		
2	95585	Capscrew/Large Flange 3/8-16UNC x 3/4 Grade 5	5	
3	9004918	PTO Bell Cover	1	
4	9004729	Belt Cover/Shield	3	
5	900060	Handle for Draw Latch	3	
6	900068	Retainer for Draw Latch	3	
7	900066	Stud Pin for Draw Latch	3	
8	900067	Washer for Draw Latch	3	
9	900059	Flexible Draw Latch Asy w/Style R Keeper	3	
10	9004940	Pop Rivet	6	
11	9004998	Rivet Washer/Burr 3/16"	6	
12	91263	Large Flange Nut 3/8-16 UNC Grade 5	2	
13	284714B	Locking Pipe Weldment with Roll Pin	1	
	9392-208	Roll Pin 1/2" Dia. x 2	-	
14	9007108	Gasket w/Adhesive Backing for Clean-Out Door	A/R	Specify in Feet
15	9006497	Plate - Latch	2	
16	289854B	Cleanout Door Weldment =Black=	1	
17	903171-574	Countersunk Screw #10-24 UNC x 1/2"	4	
18	902331	Flange Hex Nut #10-24 (Serrated)	4	

Lower Auger Linkage Components

Please visit www.unverferth.com/parts/ for the most current parts listing.

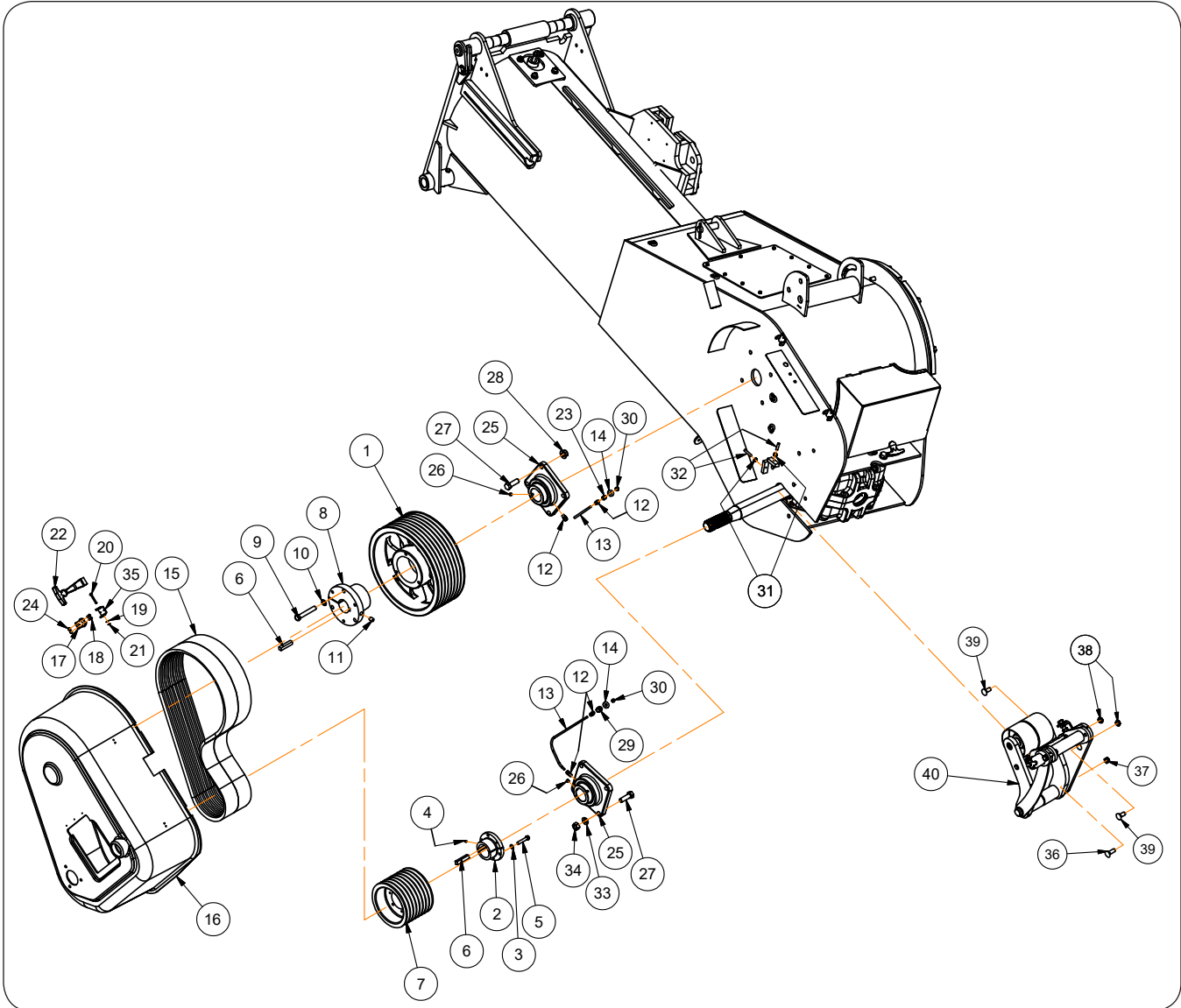

Brent 1196/1396 Right-Hand Unload — Parts

Lower Auger Linkage Components

Please visit www.unverferth.com/parts/ for the most current parts listing.

ITEM	PART NO.	DESCRIPTION	QTY	NOTES
1	9004590	Pulley, 15" Dia. x 5 13/16	1	
2	9007376	Bushing, 4 5/8 OD x 2 1/4 ID x 2 1/16 With 1/2 Keyway & Includes Capscrews	1	Includes Items 3, 4, 5
3	9404-021	Lock Washer, 3/8	3	
4	9399-059	Set Screw, 1/4-20UNC x 3/8	1	
5	284262	Split Bushing Hardware Kit	1	Includes Capscrews & Items 3 & 4
6	9002562	Keystock, 1/2 x 1/2 x 2 1/2	2	
7	9004591	Pulley, 7 1/2" Dia. x 5 13/16	1	
8	9004813	Bushing, 6 5/8 OD x 2 1/4 ID x 3 3/4 With 1/2" Keyway & Includes Capscrews	1	Includes Items 9, 10, 11
9	9006263	Bolt, 9/16-12UNC x 3 5/8	3	Grade 5
10	9404-027	Lock Washer, 9/16	3	
11	9399-107	Set Screw, 1/2"-13UNC x 5/8"	1	
12	9005073	Quickline Fitting	4	
13	9005074	Hose/Type Nylon, 1/4" OD	2	(Specify in Feet)
14	9405-076	Flat Washer, 3/8	2	
15	281675	Drive Belt Set, 4 Strand (5V750)	1	Included As Matched Pair
16	9004729	Belt Cover	1	
17	900059	Flexible Draw Latch Asy w/Style R Keeper	3	
18	9004940	Pop Rivet	6	
19	900067	Washer for Draw Latch	3	
20	900066	Stud Pin for Draw Latch	3	
21	900068	"E" Retainer for Draw Latch	3	
22	900060	Handle for Draw Latch	3	
23	9003690	Hex Pipe Coupling	1	
24	9004998	Rivet Washer/Burr 3/16"	6	
25	9005565	Flange Bearing 2 1/4" ID - 4 Bolt	2	
26	9399-084	Set Screw 3/8"-16UNC x 3/8"	4	
27	9390-124	Capscrew, 5/8-11UNC x 2	8	Grade 5
28	9003398	Lock Nut/Top, 5/8"-11UNC	4	
29	9003949	Hex Pipe Coupling 1/8" NPT Female	1	
30	93426	Grease Zerk, 1/8 NPT	2	
31	9394-004	Hex Nut, 5/16-18UNC	2	Grade 5
32	9399-079	Set Screw, 5/16-18UNC x 1 1/2 Cup Point/Hex Socket	2	
33	9404-030	Lock Washer, 5/8	4	
34	9394-014	Hex Nut, 5/8-11UNC	4	Grade 5
35	900058	Draw Latch Base	3	
36	9388-104	Carriage Bolt, 1/2"-13UNC x 1 1/2"	3	Grade 5
37	94981	Locknut, 1/2"-13UNC	3	
38	9008466	Lock Nut/Center Jam, 1/2"-13UNC	2	
39	9388-103	Carriage Bolt, 1/2"-13UNC x 1 1/4" G5	2	
40	283600B	Idler Assembly	1	Refer to "Idler Assembly Components" for parts list.

Idler Assembly Components

Please visit www.unverferth.com/parts/ for the most current parts listing.

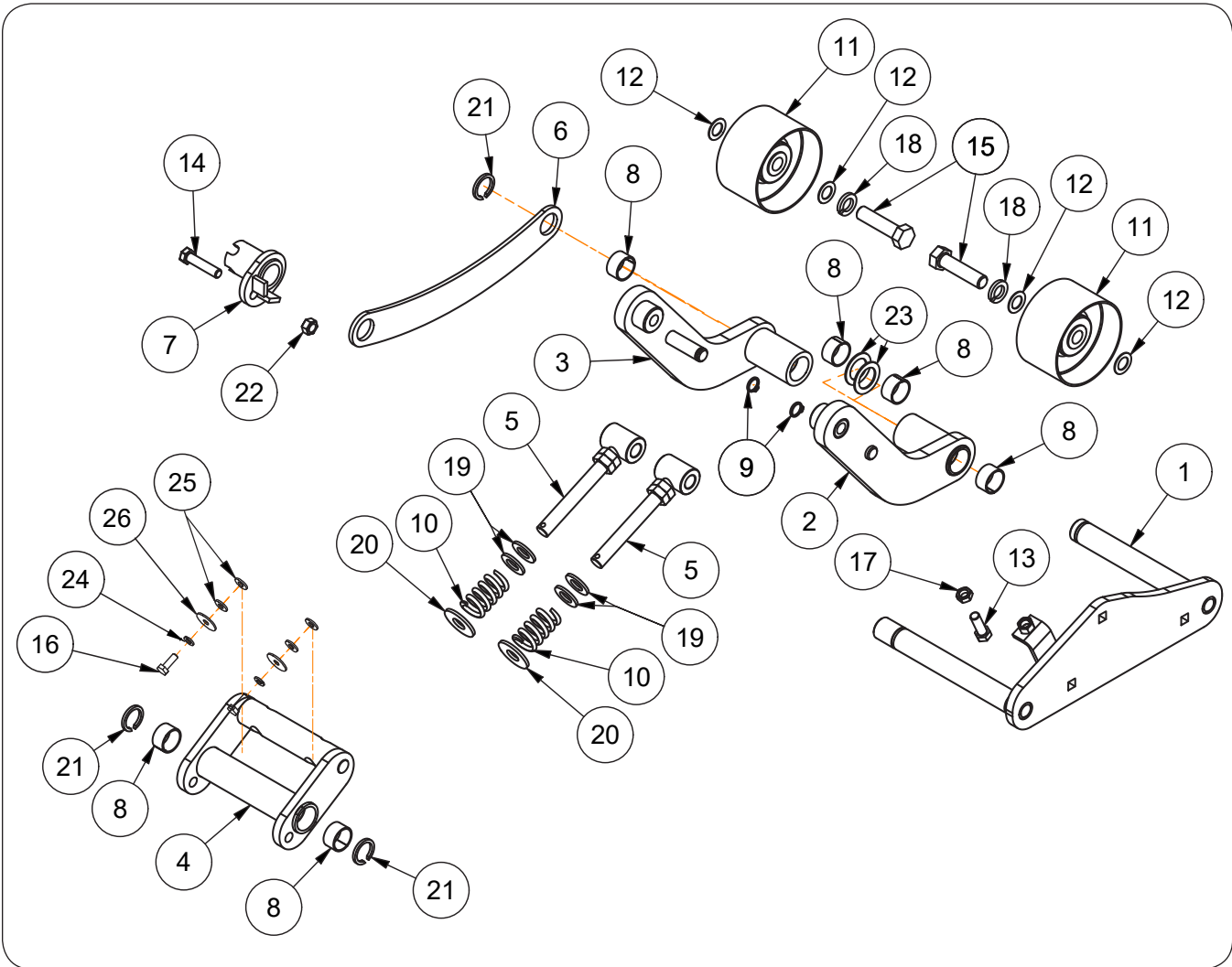

Idler Assembly Components

Please visit www.unverferth.com/parts/ for the most current parts listing.

ITEM	PART NO.	DESCRIPTION	QTY	NOTES
	283600B	Idler Assembly	1	Includes Items 1-26
1	283601B	Idler Mount Weldment	1	
2	283602B	Idler Arm Weldment	1	
3	283603B	Idler Arm Weldment	1	
4	283604B	Tensioner Weldment	1	
5	283605	Tensioner Rod Weldment	2	
6	283619B	Idler Brace Plate	1	
7	284703	Tensioner Bushing Weldment	1	
8	9003635	Self-Lubricating Bushing, 1.4" OD x 1.25" ID x 3/4"	6	
9	9003810	Snap Ring, 3/4"	2	
10	9005447	Spring, 1.415" Dia. x 2 1/2"	2	
11	9005684	Idler Sub Assembly	2	
12	9005685	Machine Washer, 3/4"	4	
13	9390-101	Capscrew 1/2"-13UNC x 1 1/2"	1	Grade 5
14	9390-104	Capscrew, 1/2"-13UNC x 2 1/4"	1	Grade 5
15	9390-149	Capscrew, 3/4"-10UNC x 3"	2	Grade 5
16	9390-003	Capscrew, 1/4"-20UNC x 3/4"	2	Grade 5
17	9395-010	Hex Jam Nut, 1/2-13UNC	1	Grade 5
18	9404-033	Lock Washer, 3/4"	2	
19	9405-104	Flat Washer, 3/4"	4	
20	9405-106	Flat Washer, 3/4"	2	
21	94144	Retaining Ring, 1 1/4"	4	
22	94981	Locknut, 1/2"-13UNC	1	
23	TA500397	Bushing, 1.875"D x .074"	2	
24	9404-017	Lock Washer, 1/4"	2	
25	9405-062	Flat Washer, 1/4" SAE	4	
26	9405-066	Flat Fender Washer, 1/4"	2	

Brent 1196/1396 Right-Hand Unload — Parts

Auger Tube Components

Please visit www.unverferth.com/parts/ for the most current parts listing.

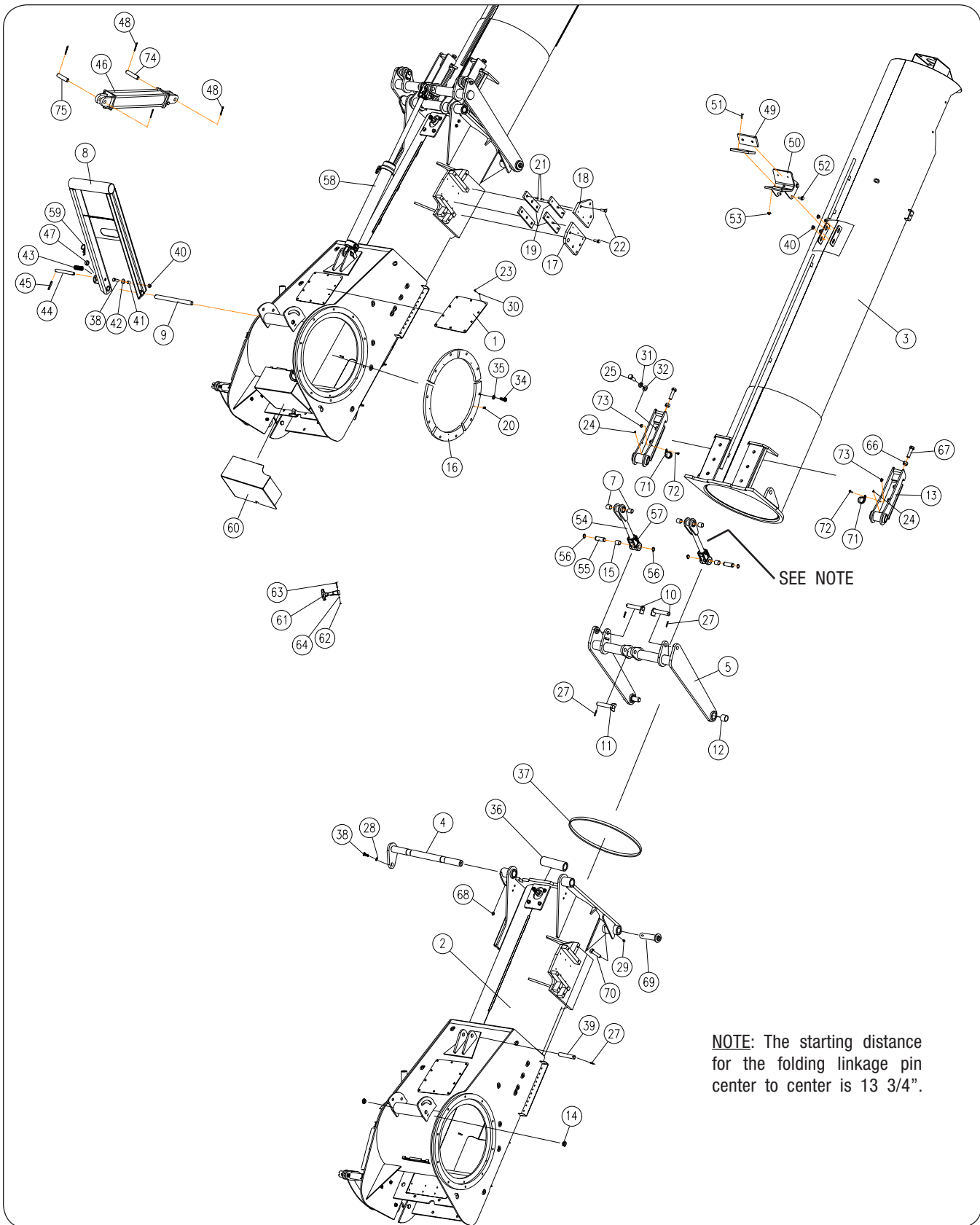

Brent 1196/1396 Right-Hand Unload — Parts

Auger Tube Components

Please visit www.unverferth.com/parts/ for the most current parts listing.

ITEM	PART NO.	DESCRIPTION	QTY	NOTES
1	283518G	Cover Plate =Green=	1	
	283518R	Cover Plate =Red=		
2	295240G	Lower Auger Housing Replacement Kit =Green=	1	
	295240R	Lower Auger Housing Replacement Kit =Red=		
3	284438G	Upper Auger Housing Weldment =Green=	1	
	284438R	Upper Auger Housing Weldment =Red=		
4	289842	Auger Hinge Pin	1	
5	293960G	Auger Fold Linkage Weldment =Green=	1	
	293960R	Auger Fold Linkage Weldment =Red=		
7	9003440	Self Lube Bushing	4	
8	272579G	Auger Support Weldment =Green=	1	
	272579R	Auger Support Weldment =Red=		
9	284549	Pivot Pin, 1" Dia. x 13 1/16	1	
10	284555	Pin Weldment, 1" Dia. (5 1/8)	2	
11	284557	Pin Weldment, 1" Dia. (4 7/8)	1	
12	9004741	Self Lubricating Bushing, 1.75 OD x 1.50 ID x 1 1/2	2	
13	289857G	Pivot Weldment =Green=	2	
	289857R	Pivot Weldment =Red=		
14	9003412	Split Output Bushing (1" ID)	2	
15	9003636	Self Lube Bushing (1" ID)	2	
16	284464B	Pivot Flange, Retainer Plate =Black=	5	
17	284518B	Fold Plate, 6 x 8 =Black=	1	
18	271119B	Fold Plate, 6 1/2 x 8 =Black=	1	
19	271124	Nylon Fold Slide, 2 x 8	4	
20	93415	Zerk, 90° 1/4-28 Thread	5	
21	9001688	Flat Head Capscrew, 5/16-18UNC x 3/4	12	
22	9390-123	Capscrew, 5/8-11UNC x 1 3/4 Grade 5	7	
23	9390-003	Capscrew, 1/4-20UNC x 3/4 Grade 5	10	
24	91160	Grease Zerk	10	
25	91299-146	Capscrew, 3/4-10UNC x 2 1/4 Grade 8	8	
27	9392-136	Roll Pin, 1/4" Dia. x 1 1/2	5	
28	9405-098	Flat Washer, 5/8"	2	Grade 5
29	902875	Center Lock Nut, 3/8"-16UNC	2	
30	9404-017	Lock Washer, 1/4	10	
31	9404-034	Lock Washer, 3/4	8	
32	9234PL	Flat Washer, 13/16 (Hardened)	8	
34	9390-122	Capscrew, 5/8-11UNC x 1 1/2 Grade 5	12	
35	9404-030	Lock Washer, 5/8	19	
36	284493G	Middle Pivot Tube, 2 1/2 OD x 7 5/8 =Green=	1	
	284493R	Middle Pivot Tube, 2 1/2 OD x 7 5/8 =Red=		
37	9003757	Gasket, 1/4 x 1/2	1	
38	9390-124	Capscrew, 5/8-11UNC x 2 Grade 5	2	

(Continued on next page)

Brent 1196/1396 Right-Hand Unload — Parts

Auger Tube Components (continued)

Please visit www.unverferth.com/parts/ for the most current parts listing.

ITEM	PART NO.	DESCRIPTION	QTY	NOTES
39	266285	Cylinder Pin, 1" Dia. x 4 1/2	1	
40	9003397	Locking Flange Nut, 1/2-13UNC Grade 5	4	
41	272583	Stop Bushing, 3/4 Dia. x 7/8	1	
42	9405-088	Flat Washer, 1/2 USS	2	
43	9001868	Locking Collar, 3/4"	1	
44	272376	Lock Pin, 3/4 Dia. x 6 3/4	1	
45	9392-182	Roll Pin, 3/8 Dia. x 2 1/2	2	
46	9000933	Auger Pivot Hydraulic Cylinder, 3 x 22" 3000 PSI	1	
47	9004772	Spring	1	
48	9391-046	Cotter Pin, 3/16 Dia. x 2	4	
49	272574	Pad, 1/2 x 3 x 6 1/2	2	
50	272553G	Auger Rest Weldment =Green=	1	
	272553R	Auger Rest Weldment =Red=		
51	903171-662	Flat Head Machine Screw, 5/16-18UNC x 1 1/4	4	
52	91266	Flange Screw, 1/2-13UNC x 1 1/4 Grade 5	4	
53	91257	Large Hex Flange Nut, 5/16-18UNC Grade 5	4	
54	284687	Fold Linkage Weldment	2	
55	272587	Pin, 1 Dia. x 3 1/8	2	
56	91192	Retaining Ring, 1"	4	
57	9006491	Clevis	2	
58	9004730	Hydraulic Cylinder, 3 x 22" - 3000 PSI	1	
59	92424	Hairpin Cotter	1	
60	294462B	Cover Plate	1	
61	900060	Handle for Draw Latch	3	
62	900068	Retainer for Draw Latch	3	
63	900066	Stud Pin for Draw Latch	3	
64	900067	Washer for Draw Latch	3	
66	9394-016	Hex Nut 3/4-10UNC	2	
67	94733	Capscrew 3/4"-10UNC x 3" Full Threaded	2	
68	9003398	Locknut 5/8"-11UNC	1	
69	293385	Auger Linkage Pin Weldment	2	
70	9390-005	Capscrew, 1/4"-20UNC x 1" Grade 5	2	
71	9008559	Cable Clamp, 1 1/2" Dia. x 3/4" (SS)	2	
72	91262	Flange Screw, 3/8"-16UNC x 1" Grade 5	2	
73	91263	Flange Nut, 3/8"-16UNC	2	
74	250104	Pin 1" Dia. x 4"	1	
75	804572	Pin 1" Dia. x 3 1/2"	1	

Notes

Please visit www.unverferth.com/parts/ for the most current parts listing.

Empty rounded rectangular box for notes.

Auger Grease Bank Components

Please visit www.unverferth.com/parts/ for the most current parts listing.

NOTE: For more auger grease bank details, refer to “Lubrication” in the MAINTENANCE section.

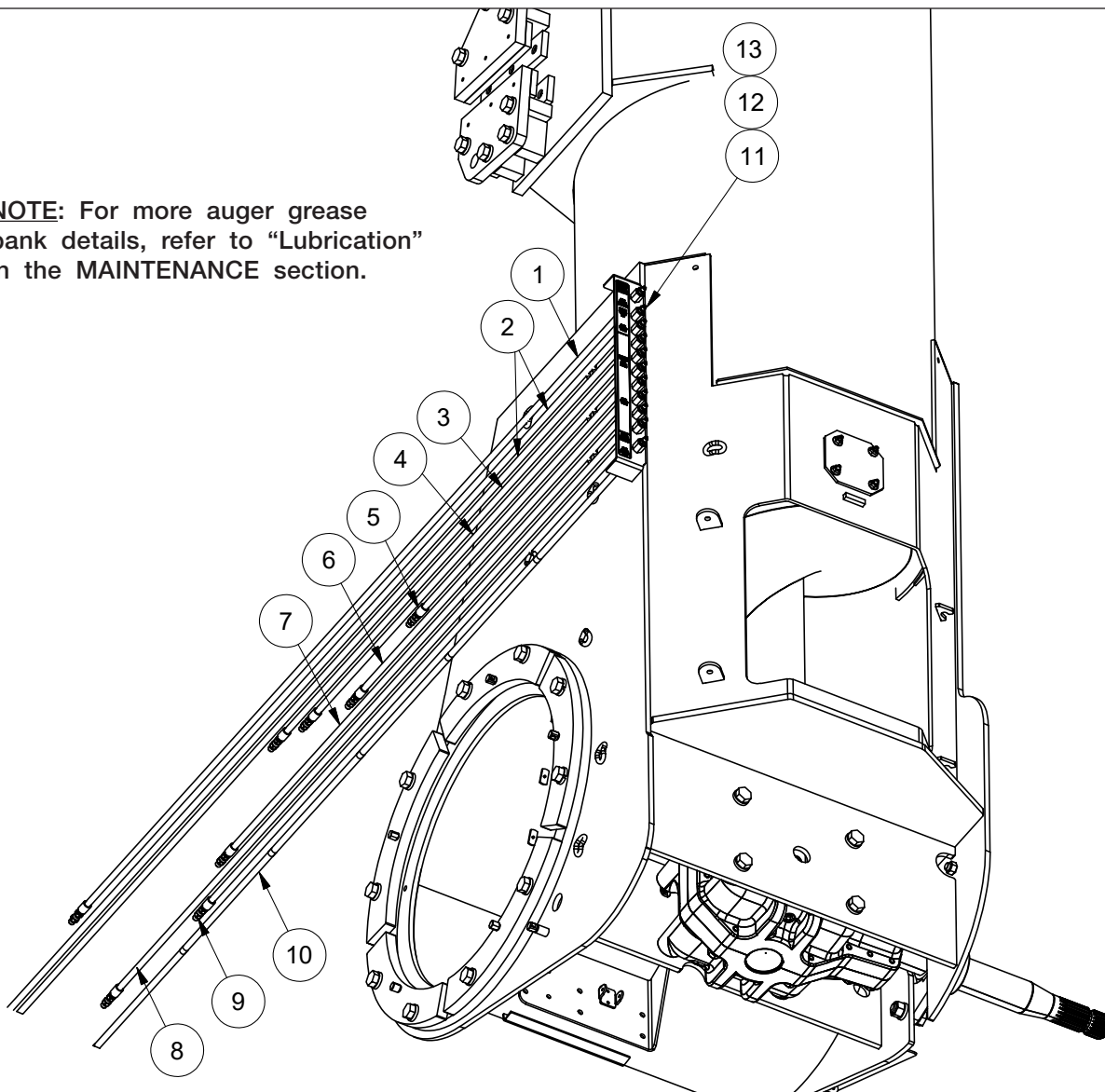

ITEM	PART NO.	DESCRIPTION	QTY	NOTES
1	9008965	Grease Hose 3/16" x 74" (1/8" NPT)	1	Lower Vertical Auger Hanger Bearing
2	9008967	Grease Hose 3/16" x 126" (1/8" NPT)	2	Upper Auger Pivot Pin
3	9008961	Grease Hose 3/16" x 48" (1/8" NPT)	1	Vertical Auger Pivot Rings
4	9008960	Grease Hose 3/16" x 44" (1/8" NPT)	1	
5	9008958	Grease Hose 3/16" x 30" (1/8" NPT)	1	
6	9008959	Grease Hose 3/16" x 38" (1/8" NPT)	1	
7	9008962	Grease Hose 3/16" x 55" (1/8" NPT)	1	
8	9008964	Grease Hose 3/16" x 70" (1/8" NPT)	1	
9	9008963	Grease Hose 3/16" x 58" (1/8" NPT)	1	
10	9008968	Grease Hose 3/16" x 134" (1/8" NPT)	1	Drag Auger Center Bearing
11	9003949	Coupler 1/8" NPT	11	
12	93426	Grease Zerk	11	
13	9006849	Grease Zerk Cap	11	

**Electric Over Hydraulic Valve Functions and Wire Locations
5 Spool (Optional)**

Please visit www.unverferth.com/parts/ for the most current parts listing.

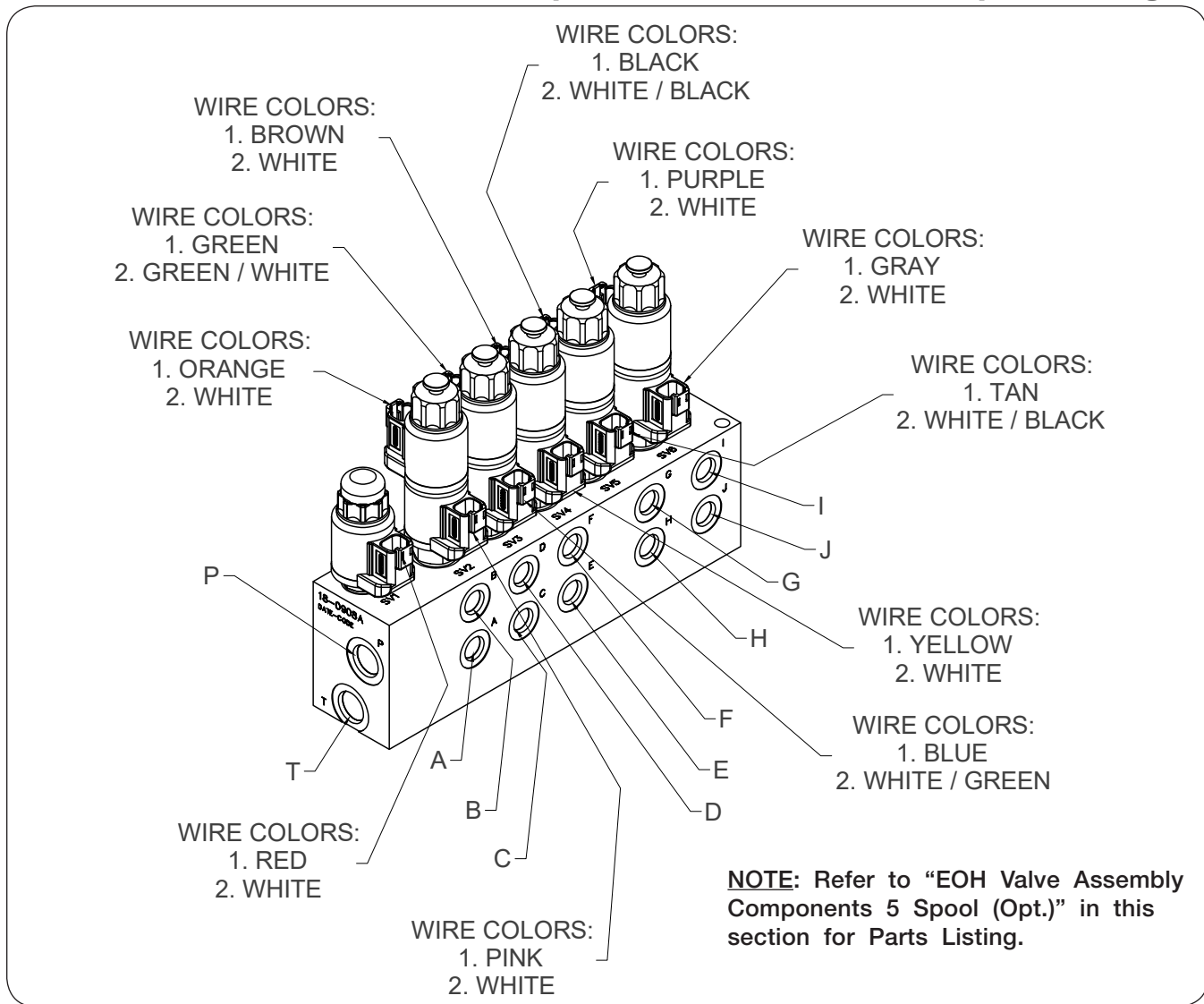

PORT	END OF CYLINDER	FUNCTION
A	BUTT END	Flow Door
B	RAM END	Flow Door
C	RAM END	Auger Fold
D	BUTT END	Auger Fold
E	RAM END	Spout Tilt Out
F	BUTT END	Spout Tilt In
G	RAM END	Joystick / Spout Rotate
H	BUTT END	Joystick / Spout Rotate
I	BUTT END	Auger Pivot Down
J	RAM END	Auger Pivot Up
P		Tractor Pressure
T		Tractor Return

EOH Valve Assembly Components 5 Spool (Optional)

Please visit www.unverferth.com/parts/ for the most current parts listing.

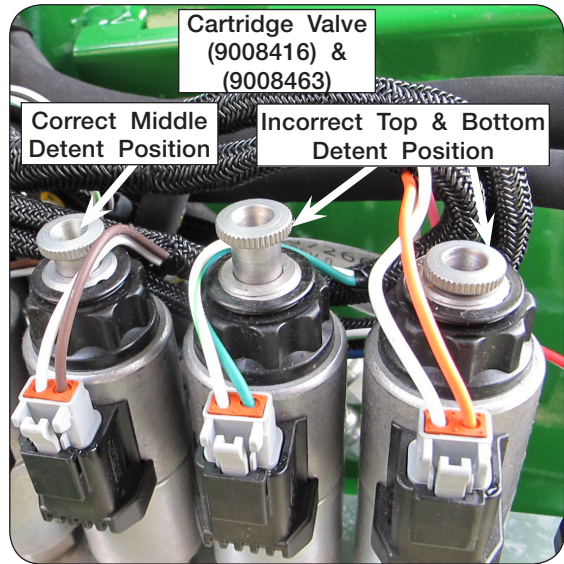
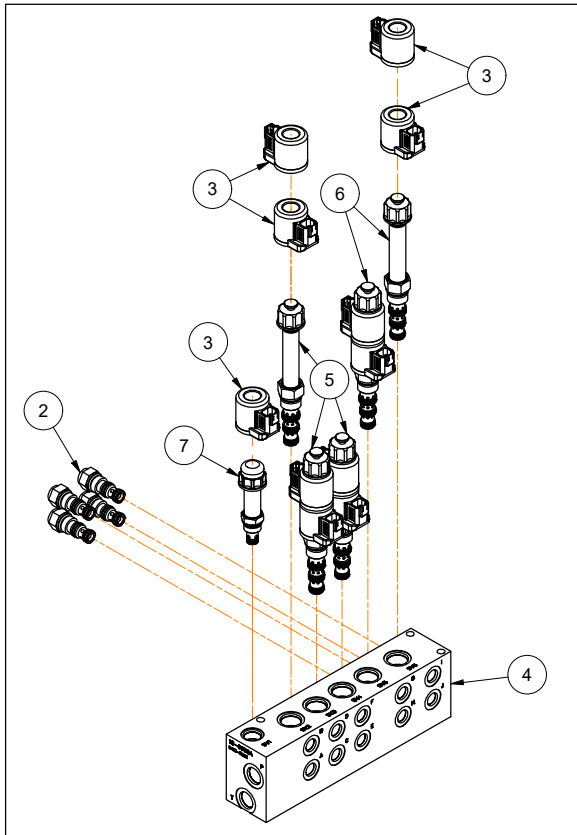

Cartridge Valve (9008416) & (9008463)
Middle Detent Position

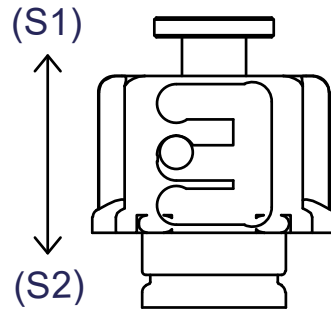

PUSH BUTTON
AND HOLD
WHILE OPERATING
INDIVIDUAL FUNCTIONS

Cartridge Valve (9008438)

FOR MANUAL OVERRIDE

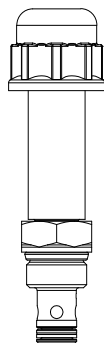

NOTE: Refer to “Manual Override for Optional Electric Over Hydraulic System” in OPERATION section.

EOH Valve Assembly Components 5 Spool (Optional)

Please visit www.unverferth.com/parts/ for the most current parts listing.

ITEM	PART NO.	DESCRIPTION	QTY.	NOTES
1	293416	EOH Block Assembly - 5 Spool Replacement Kit	1	Includes Items 2-7 and Instruction Sheet
2	9003856	Pilot Check Valve	4	
3	9005769	Coil - 12 VDC DN-40	11	
4	9008667	Manifold Block - 5 Spool	1	
5	9008416	Cartridge Valve - 4 Way, 3 Position - Closed Center w/Detented Manual Override	3	Includes Retaining Cap
	9003906	Seal Kit	-	
6	9008463	Cartridge Valve - 4 Way, 3 Position - Open Center w/Detented Manual Override	2	Includes Retaining Cap
	9003906	Seal Kit	-	
7	9008438	Cartridge Valve - 2 Way, 2 Position w/Push Type Manual Override	1	
	9003904	Seal Kit	-	

EOH Tractor Circuit Hydraulic Components (Optional)

Please visit www.unverferth.com/parts/ for the most current parts listing.

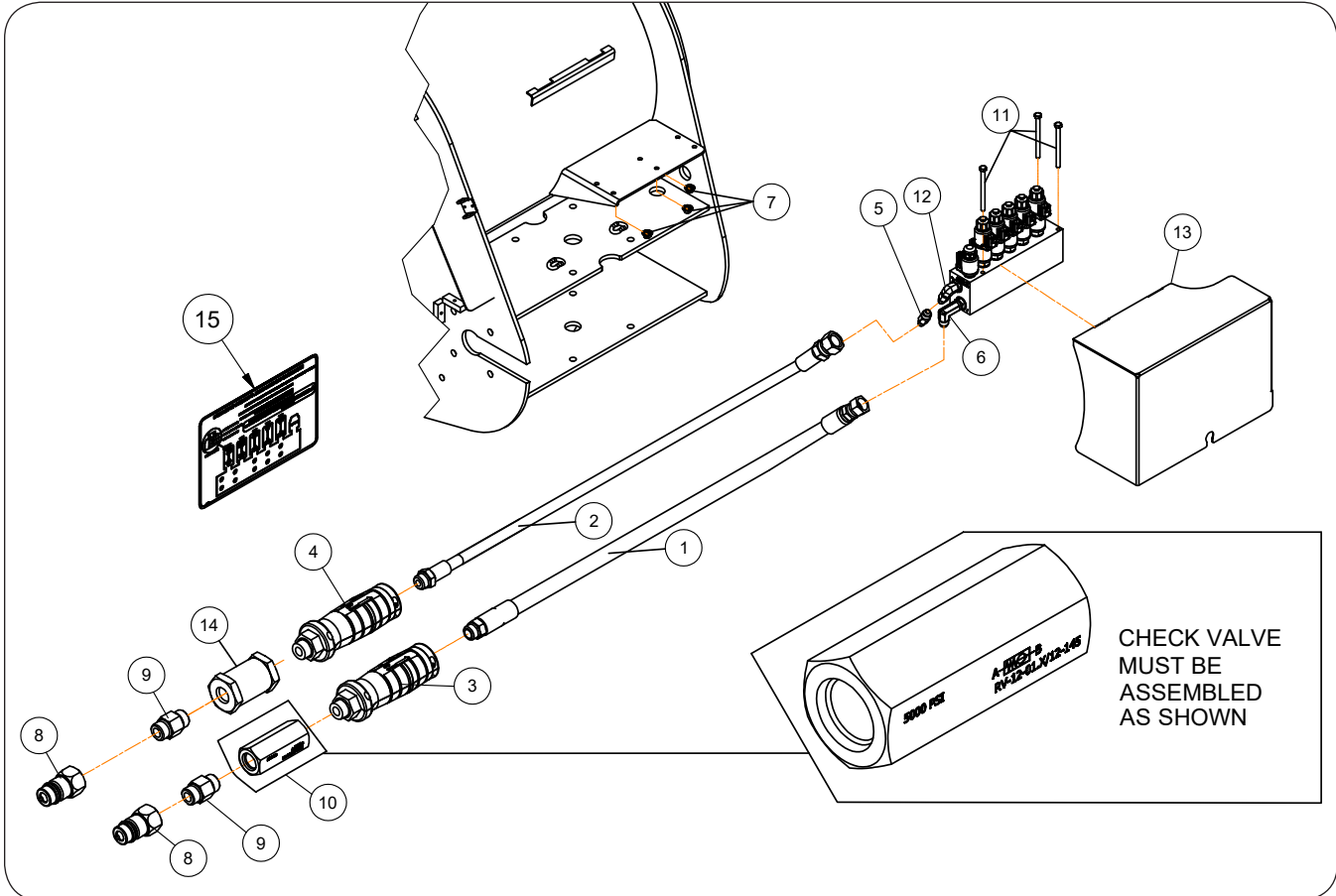

EOH Tractor Circuit Hydraulic Components (Optional)

Please visit www.unverferth.com/parts/ for the most current parts listing.

ITEM	PART NO.	DESCRIPTION	QTY.	NOTES
1	95802	Hydraulic Hose, 1/2 x 205" - 3000 PSI	1	
2	9005574	Hydraulic Hose, 1/4 x 208" - 3000 PSI	1	
3	9008601	Hose Grips - Tan (Pair) - Hydraulic Return	1	Half Tan/Half Gray - Cylinder Retracted
4	9008601	Hose Grips - Tan (Pair) - Hydraulic Pressure	1	Solid Tan - Cylinder Extended
5	9006527	JIC Tube Reducer 9/16-18 UNF Male x 9/16-UNF Female	1	
6	901568	Elbow, 90° Extra Long 3/4-16 JIC x 3/4-16 Male O-Ring	1	
7	91257	Large Flange Hex Nut, 5/16-18UNC Gr.5	3	
8	91383	Male Tip Coupling, 3/4-16	2	
9	98508	Adapter 3/4-16 O-Ring Male x 3/4-16 O-Ring Male	2	
10	9006994	Check Line Valve 145 PSI	1	
11	9390-042	Capscrew, 5/16-18UNC x 4 Gr.5	3	
12	9874	Elbow, 90° 9/16-18 JIC Male x 3/4-16 OR ADJ Male	1	
13	294462B	Valve Cover Plate	1	Also Order Item #15
14	9005403	120 Micron Hydraulic Filter	1	
15	9008564	Decal, CAUTION (Valve Block)	1	Add To Inside Cover Plate #13

Optional Spout Rotate and Tilt Hydraulic Components

Please visit www.unverferth.com/parts/ for the most current parts listing.

OPTIONAL SPOUT ROTATE

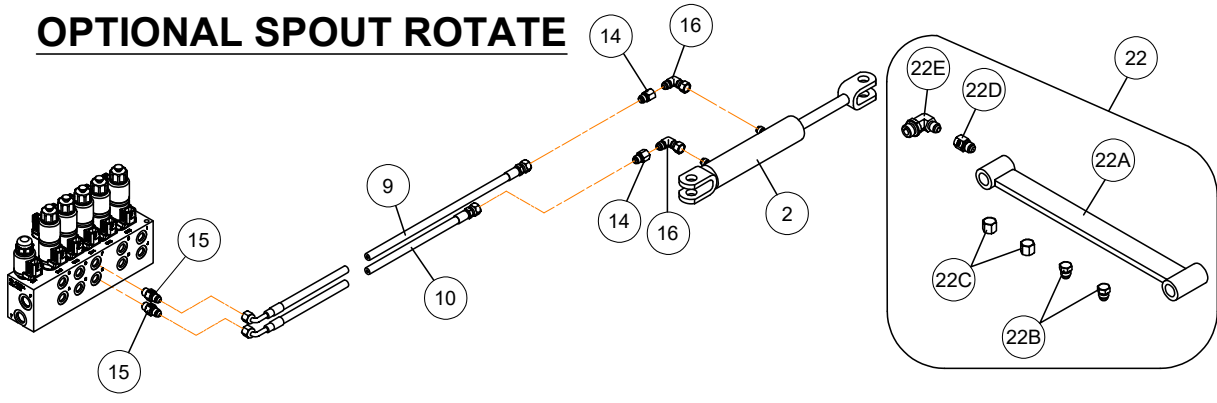

SPOUT TILT

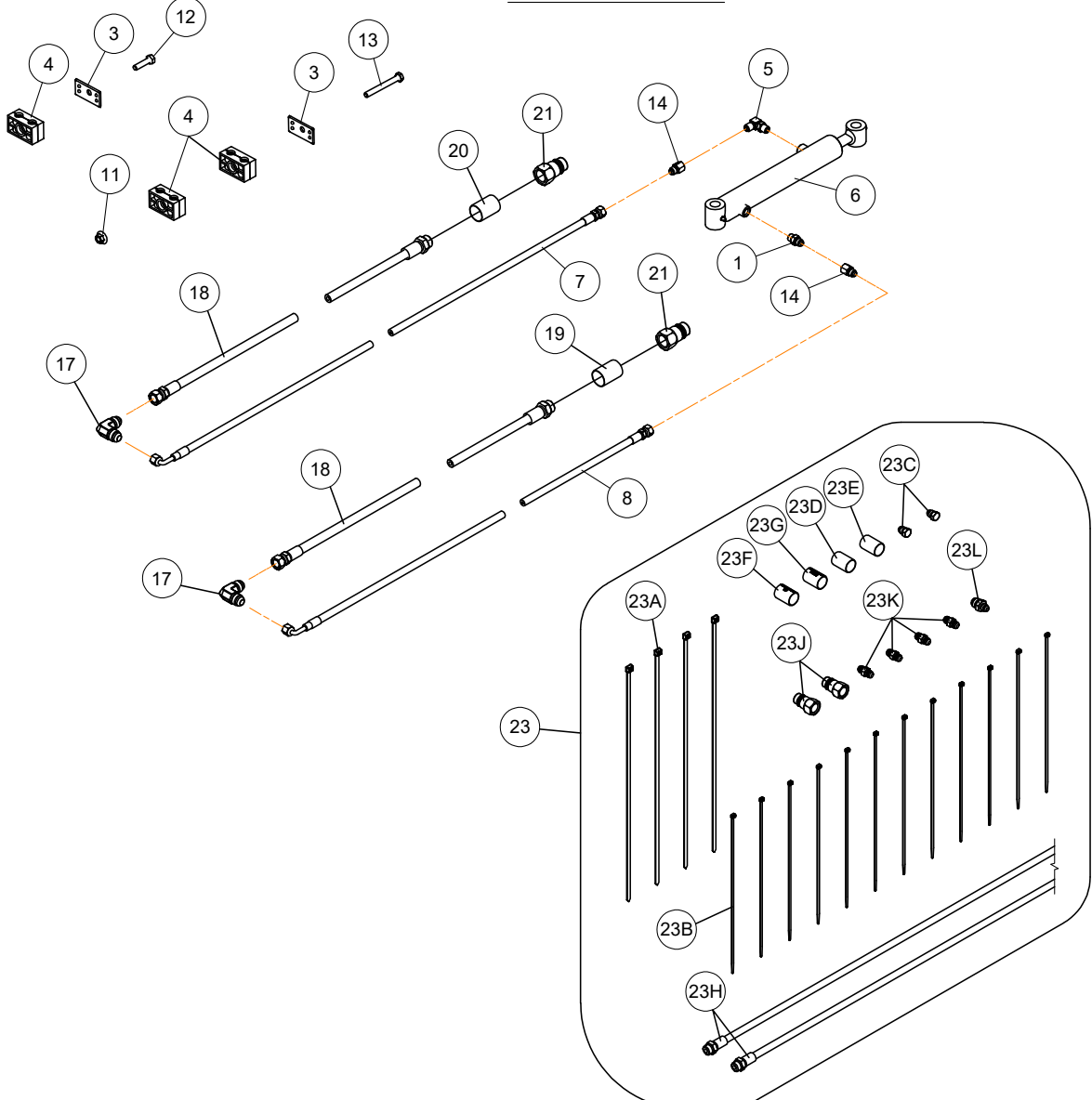

Brent 1196/1396 Right-Hand Unload — Parts

Optional Spout Rotate and Tilt Hydraulic Components

Please visit www.unverferth.com/parts/ for the most current parts listing.

ITEM	PART NO.	DESCRIPTION	QTY.	NOTES
1	9001495	Adapter, 9/16-18 JIC Male x 9/16-18 OR Male	1	
2	9007124	Hydraulic Cylinder, 1 1/2 x 3 - 3000 PSI	1	
3	9003814	Clamp Top Plate, 1/4 x 1 1/8 x 2 1/16	4	
4	9003816	Clamp, Polypropylene	4	
5	9004379	Elbow, 90° 9/16-18 JIC Male x 9/16-18 OR ADJ Male	1	
6	9005135	Hydraulic Cylinder, 1 1/2 x 8 - 3000 PSI	1	
7	9006579	Hydraulic Hose, 1/4 x 321" - 3000 PSI	1	
8	9006580	Hydraulic Hose, 1/4 x 312" - 3000 PSI	1	
9	9006581	Hydraulic Hose, 1/4 x 295" - 3000 PSI	1	
10	9006582	Hydraulic Hose, 1/4 x 290" - 3000 PSI	1	
11	91257	Large Flange Hex Nut, 5/16-18UNC Grade 5	1	
12	9390-031	Capscrew, 5/16-18UNC x 1 1/4 Grade 5	1	
13	9390-034	Capscrew, 5/16-18UNC x 2 Grade 5	3	
14	95193	Adapter, 9/16-18 JIC Female x 9/16-18 JIC Male	5	
15	98435	Adapter, 9/16-18 JIC Male x 9/16-18 OR Male	4	
16	9876	Elbow, 90° 9/16-18 JIC Male x 9/16-18 JIC Female	2	
17	9897	Elbow, 90° 9/16-18 JIC Male x 9/16-18 JIC Male	2	
18	9005574	Hydraulic Hose, 1/4 x 208" - 3000 PSI	2	
19	9008598	Hose Grips - Yellow (Pair) - Spout Out	1	Solid Yellow - Cylinder Extended
20	9008598	Hose Grips - Yellow (Pair) - Spout In	1	Half Yellow/Half Gray - Cylinder Retracted
21	91383	Male Tip Coupling, 3/4-16	2	
22	286910	Spout Rotate Lock Out Kit	1	When Optional Electric-Over-Hydraulic Items are Installed, Remove Items 22A through 22E
22A	286914B	15" Link Weldment, Spout Lockout =Black=	1	
22B	9001825	Plug, 9/16-18 JIC Male	2	
22C	9001850	Cap Nut, 9/16-18 JIC Female	2	
22D	9002199	Reducer, 9/16-18 JIC Female x 9/16-18 JIC Male	1	
22E	9874	Elbow, 90° 9/16-18 JIC Male x 3/4-16 OR Adj. Male	1	
23	286920	Hydraulic Conversion Kit (EOH TO SCV)	1	
23A	9000104	Cable Tie, 5/16" x 21 1/2	4	
23B	9000107	Cable Tie, 14 1/2 x 0.19	12	
23C	9001825	Plug, 9/16-18 JIC Male	2	
23D	9003999	Sleeve-Hose Marker, Spout Out	1	
23E	9004000	Sleeve-Hose Marker, Spout In	1	
23F	9004001	Sleeve-Hose Marker, Auger Pivot Up	1	
23G	9004002	Sleeve-Hose Marker, Auger Pivot Down	1	
23H	9005574	Hydraulic Hose, 1/4 x 208 - 3000 PSI	2	
23J	91383	Male Tip Coupling, 3/4-16	2	
23K	92295	Adapter, 9/16-18 JIC Male x 9/16-18 JIC Male	4	
23L	95975	Adapter, 3/4-16 JIC Male x 9/16-18 JIC Male	1	

Brent 1196/1396 Right-Hand Unload — Parts

Auger Pivot Hydraulic Components

Please visit www.unverferth.com/parts/ for the most current parts listing.

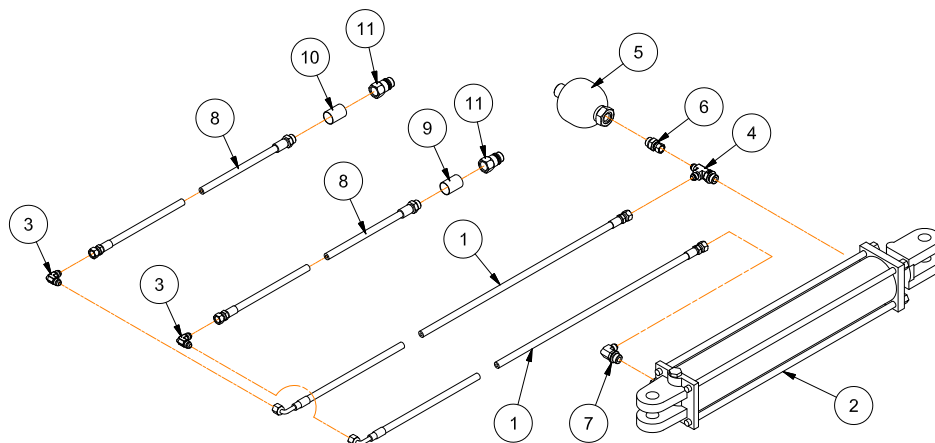

ITEM	PART NO.	DESCRIPTION	QTY.	NOTES
1	9000925	Hydraulic Hose, 1/4 x 78" - 3000 PSI	2	
2	9000933	Hydraulic Cylinder, 3 1/2 x 20 - 3000 PSI	1	
3	9897	Elbow, 90° 9/16-18 JIC Male x 9/16-18 JIC Male	2	
4	9002155	Tee, 9/16-18 JIC Male x 3/4-16 OR ADJ Male Boss Run x 9/16-18 JIC Male Branch	1	
5	9002719	Accumulator - 1800 PSI	1	
6	9002720	Adapter, 3/4-16 OR Male x 9/16-18 JIC Female	1	
7	9874	Elbow, 90° 9/16-18 JIC Male x 3/4-16 OR ADJ Male	6	
8	9005574	Hydraulic Hose, 1/4 x 208" - 3000 PSI	2	
9	9008599	Hose Grips - Blue (Pair) - Auger Pivot Up	1	Half Blue/Half Gray - Cylinder Retracted
10	9008599	Hose Grips - Blue (Pair) - Auger Pivot Down	1	Solid Blue - Cylinder Extended
11	91383	Male Tip Coupling, 3/4-16	2	

Brent 1196/1396 Right-Hand Unload — Parts

Auger Fold Hydraulic Components - 5 Function Hydraulic Block

Please visit www.unverferth.com/parts/ for the most current parts listing.

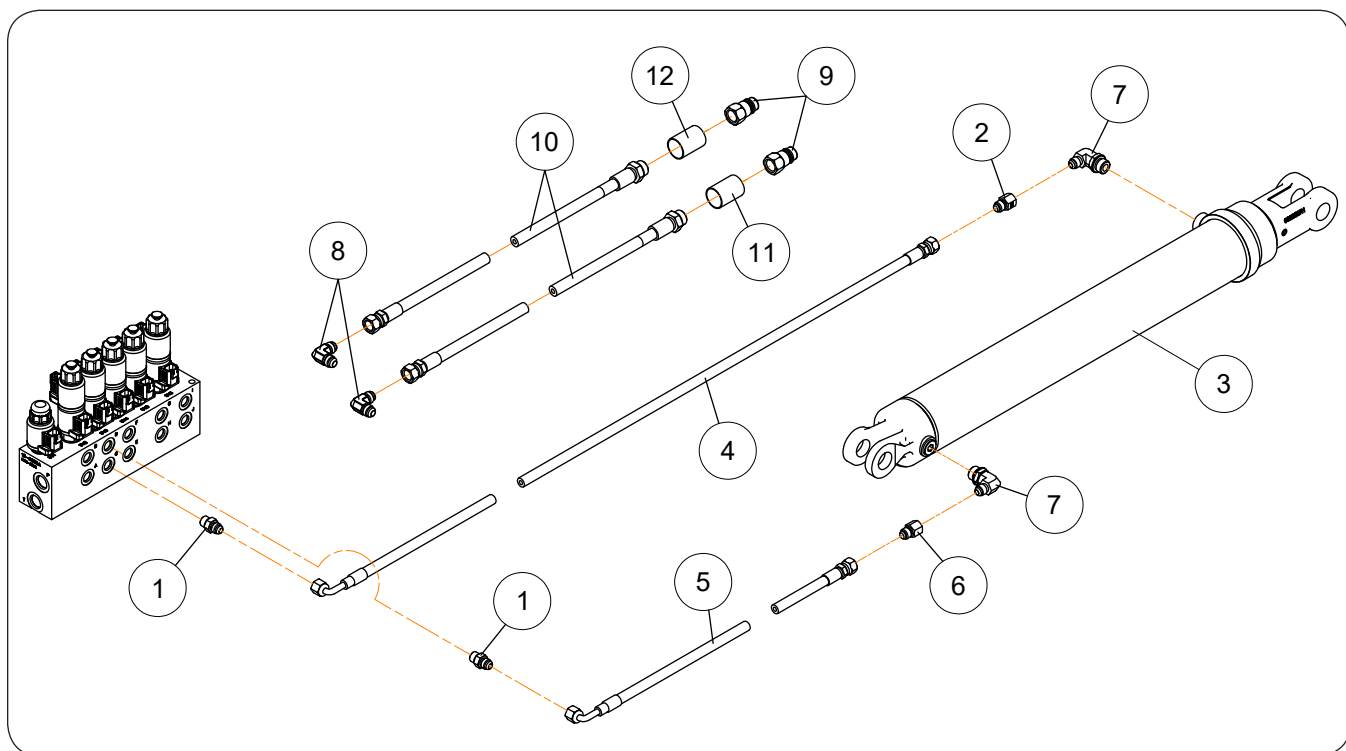

ITEM	PART NO.	DESCRIPTION	QTY.	NOTES
1	9001495	Adapter, 9/16-18 JIC Male x 9/16-18 OR Male	9	
2	9002199	Reducer, 9/16-18 JIC Female x 9/16-18 JIC Male	1	
3	9004730	Hydraulic Cylinder, 3 x 22" - 3000 PSI	1	
4	9006608	Hydraulic Hose, 1/4 x 84" - 3000 PSI	1	
5	93594	Hydraulic Hose, 1/4 x 59" - 3000 PSI	1	
6	9003303	Adapter, 9/16-18 JIC Female x 9/16-18 JIC Male	1	0.045 (Blue) Restrictor
7	9874	Elbow, 90° 9/16-18 JIC Male x 3/4-16 OR ADJ Male	6	
8	9897	Elbow, 90° 9/16-18 JIC Male x 9/16-18 JIC Male	2	
9	91383	Male Tip Coupling, 3/4-16	2	
10	9005574	Hydraulic Hose, 1/4 x 208" - 3000 PSI	2	
11	9008597	Hose Grips - Green (Pair) - Auger Raise	1	Solid Green - Cylinder Extended
12	9008597	Hose Grips - Green (Pair) - Auger Lower	1	Half Green/Half Gray - Cylinder Retracted

Flow Door Circuit Hydraulic Components 5 Function Hydraulic Block

Please visit www.unverferth.com/parts/ for the most current parts listing.

Flow Door Cylinder

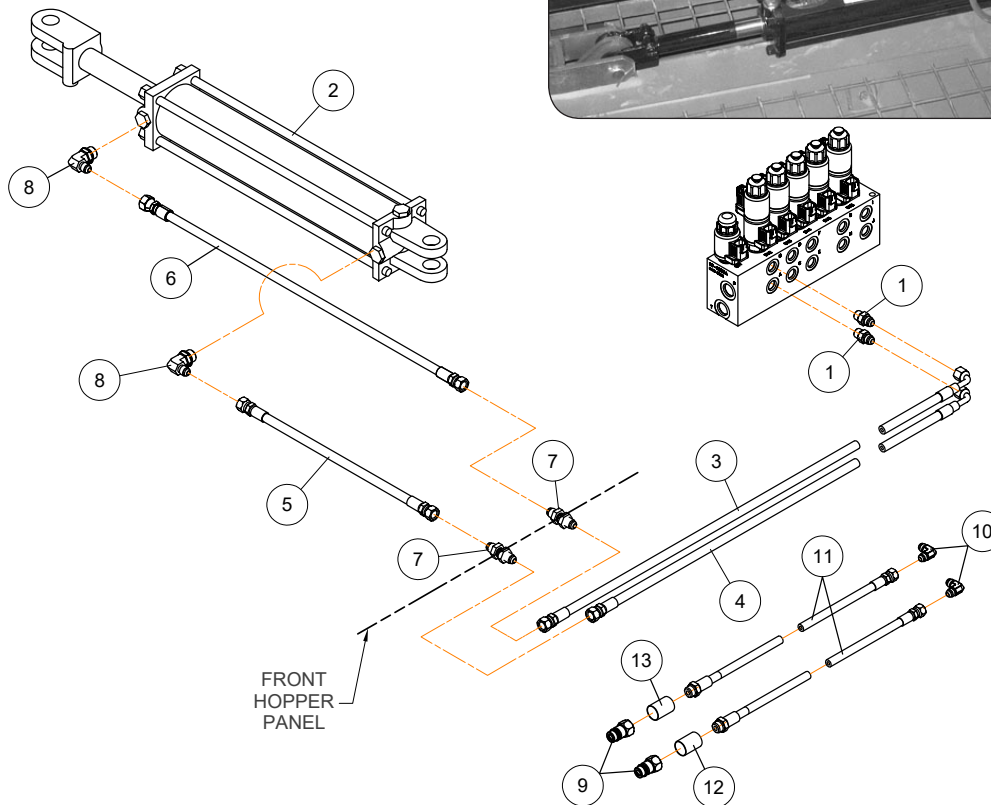
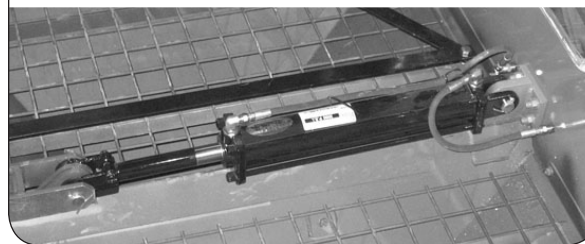

ITEM	PART NO.	DESCRIPTION	QTY.	NOTES
1	9001495	Adapter, 9/16-18 JIC Male x 9/16-18 OR Male	9	
2	9002575	Hydraulic Cylinder, 3 x 16" - 3000 PSI	1	
3	9004442	Hydraulic Hose, 1/4 x 54" - 3000 PSI	1	
4	9006607	Hydraulic Hose, 1/4 x 50" - 3000 PSI	1	
5	93472	Hydraulic Hose, 1/4 x 16" - 3000 PSI	1	
6	9002888	Hydraulic Hose, 1/4 x 27" - 3000 PSI	1	
7	95192	Bulkhead Union, 9/16-18 JIC Male x 9/16-18 JIC Male	2	
8	9874	Elbow, 90° 9/16-18 JIC Male x 3/4-16 OR ADJ Male	6	
9	91383	Male Tip Coupling, 3/4-16	2	
10	9897	Elbow, 90° 9/16-18 JIC Male x 9/16-18 JIC Male	2	
11	9005574	Hydraulic Hose, 1/4 x 208" - 3000 PSI	2	
12	9008596	Hose Grips - Red (Pair) - Flow Door Open	1	Half Red/Half Gray - Cylinder Retracted
13	9008596	Hose Grips - Red (Pair) - Flow Door Close	1	Solid Red - Cylinder Extended

Cylinders

Please visit www.unverferth.com/parts/ for the most current parts listing.

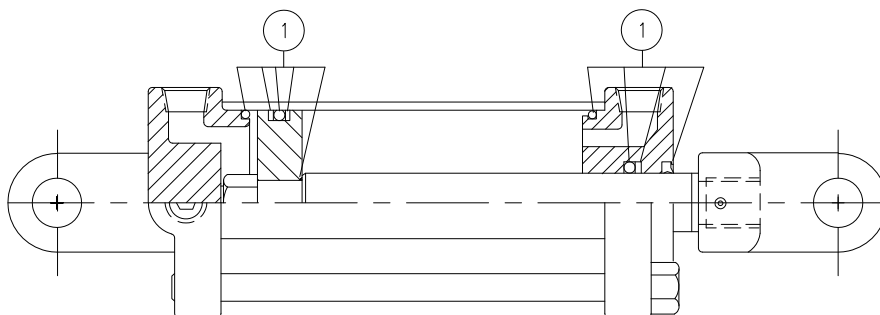

Auger Fold Cylinder - 3" x 22"

ITEM	PART NO.	DESCRIPTION	QTY.	NOTES
	9004730	Cylinder, Complete	1	
1	9003772	Seal Kit	1	

Auger Flow Door Cylinder - 3" x 16"

ITEM	PART NO.	DESCRIPTION	QTY.	NOTES
	9002575	Cylinder, Complete	1	
1	9003772	Seal Kit	1	

Auger Pivot Cylinder - 3 1/2" x 20"

ITEM	PART NO.	DESCRIPTION	QTY.	NOTES
	9000933	Cylinder, Complete	1	
1	9001081	Seal Kit	1	

Auger Spout Tilt Cylinder - 1 1/2" x 8"

ITEM	PART NO.	DESCRIPTION	QTY.	NOTES
	9005135	Cylinder, Complete	2	#6 9/16-18 O-Ring Ports (3000 PSI)
1	9005419	Seal Kit	2	

Optional Spout Rotate Cylinder - 1 1/2" x 3"

ITEM	PART NO.	DESCRIPTION	QTY.	NOTES
	9007124	Cylinder, Complete	2	
1	9006917	Seal Kit	2	

Optional Jack Cylinder - 3 1/2" x 8"

ITEM	PART NO.	DESCRIPTION	QTY.	NOTES
	9009047	Cylinder, Complete	1	
1	9007880	Seal Kit	1	

Hopper Flow Door Components

Please visit www.unverferth.com/parts/ for the most current parts listing.

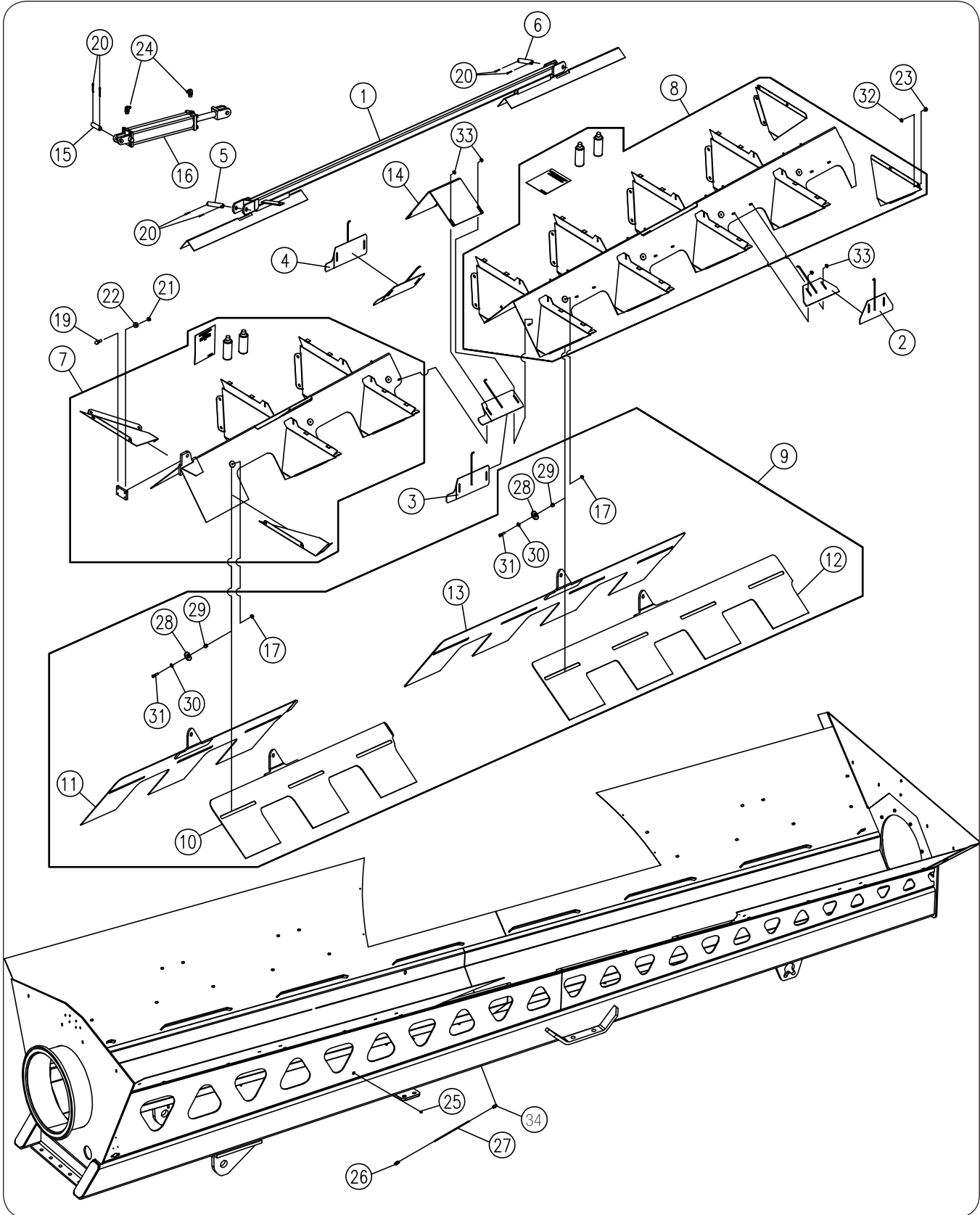

Brent 1196/1396 Right-Hand Unload — Parts

Hopper Flow Door Components

Please visit www.unverferth.com/parts/ for the most current parts listing.

ITEM	PART NO.	DESCRIPTION	QTY	NOTES
1	294155B	Flow Door Linkage Replacement Kit =Black=	1	
2	284721B	Restrictor Weldment	8	
3	284723B	Center Door Weldment Left-Hand	1	
4	284724B	Center Door Weldment Right-Hand	1	
5	266285	Idler Pin 1" Dia. x 4 1/2	1	
6	271112	Idler Pin 1" Dia. x 4	1	
7	294080B	Front Tent Service Kit (Black)	1	Includes: Front Tent Weldment, Baffle Plates, Spray Paint & Instruction Sheet
8	294081B	Rear Tent Service Kit (Black) (SHOWN)	1	Models with Single Axle Includes: Rear Tent Weldment, Baffle Plates, Spray Paint & Instruction Sheet
	294082B	Rear Tent Service Kit (Black)	1	Models with Walking Tandem Includes: Rear Tent Weldment, Baffle Plates, Spray Paint & Instruction Sheet
9	284887B	Flow Door (Service Kit) (Black)	1	Includes Items: 10, 11, 12, 13, 17, 28, 29, 30, 31
10	284848B	Front Door Weldment Left-Hand =Black=	1	
11	284847B	Front Door Weldment Right-Hand =Black=	1	
12	284850B	Rear Door Weldment Left-Hand =Black=	1	
13	284849B	Rear Door Weldment Right-Hand =Black=	1	
14	284187B	Cover Plate =Black=	1	
15	804572	Pin 1" Dia. x 3 1/2	1	
16	9002575	Cylinder 3x16	1	
17	9003396	Locknut 3/8-16UNC	14	
19	9390-103	Capscrew 1/2-13UNC x 2 Grade 5	4	
20	9391-046	Cotter Pin 3/16" Dia. x 2	6	
21	9394-010	Hex Nut 1/2-13UNC Grade 5	4	
22	9404-025	Lock Washer 1/2"	4	
23	95585	Capscrew/Large Flange 3/8-16UNC x 3/4	60	Grade 5
24	9874	90° Elbow 9/16-18 JIC Male x 3/4-16 O-Ring Adj Male Boss	2	
25	93426	Grease Zerk	1	
26	9005073	Quicklinc Fitting 1/4 Tube x 1/8 NPT Straight	1	
27	9005074	Tube, Nylon 1/4" OD	1	
28	284168	Spacer Bushing, 2 1/4 OD x 1/2	14	
29	284169	Roller Bushing	14	
30	9005471	Flat Washer, 3/8	14	
31	91299-057	Capscrew, 3/8-16UNC x 1 1/2	14	
32	9008159	Large Flange Locknut 3/8-16UNC	60	
33	91263	Locknut 3/8-16UNC	24	
34	9005072	Quicklinc Fitting 1/4 Tube x 1/8 NPT Elbow	1	

Brent 1196/1396 Right-Hand Unload — Parts

Downspout Components

Please visit www.unverferth.com/parts/ for the most current parts listing.

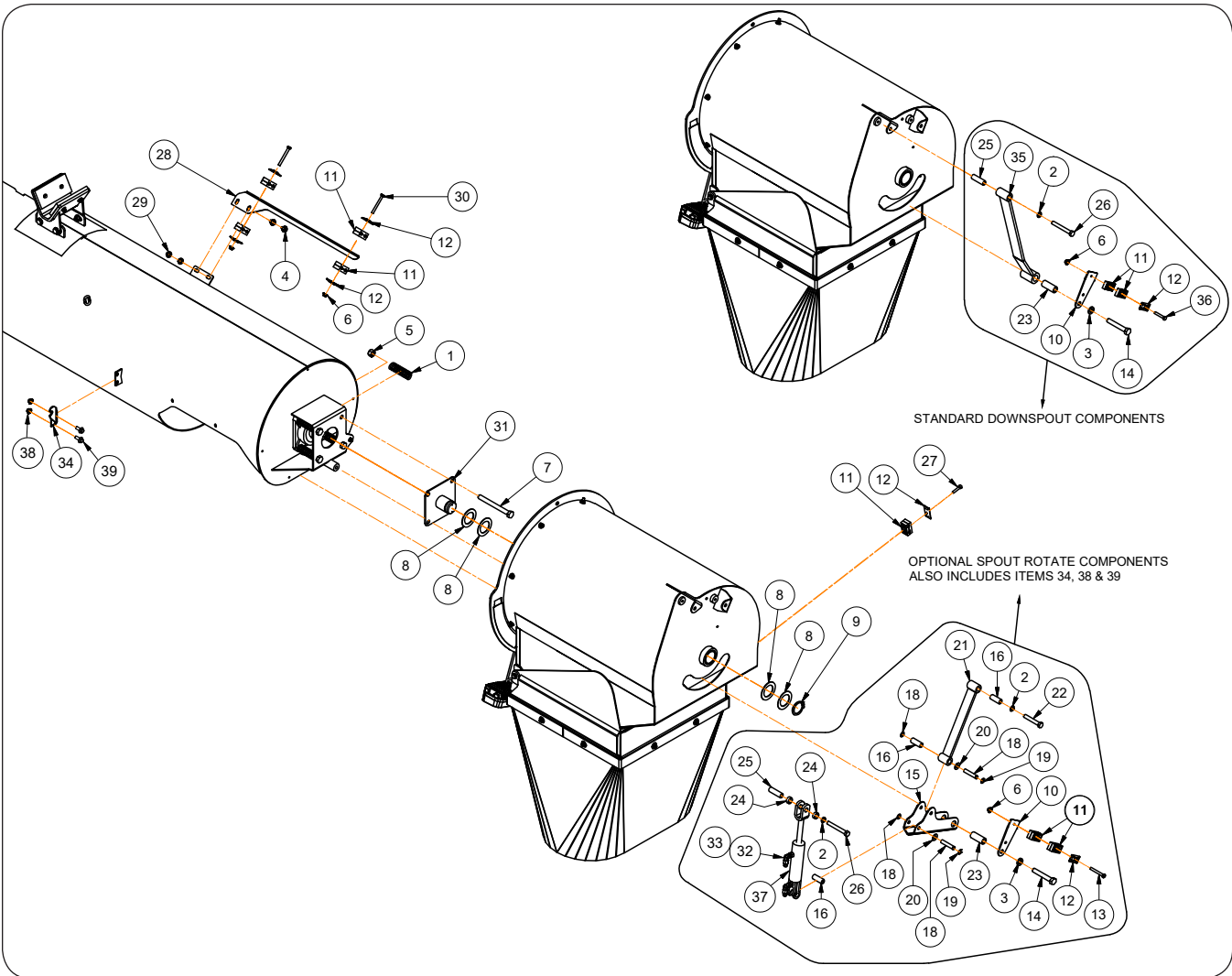

Brent 1196/1396 Right-Hand Unload — Parts

Downspout Components

Please visit www.unverferth.com/parts/ for the most current parts listing.

ITEM	PART NO.	DESCRIPTION	QTY	NOTES
1	9004899	Spring-Compression	4	
2	9404-025	Lock Washer, 1/2	15	
3	9404-030	Lock Washer, 5/8 EXTRA	20	
4	95585	Capscrew/Lrg Flg, 3/8-16UNC x 3/4 Gr.5	4	
5	9801	Locknut/Top, 5/8-11UNC	4	
6	91257	Flange Nut, 5/16-18UNC	10	
7	9390-137	Capscrew, 5/8-11UNC x 6 1/2 Gr.5	4	
8	93974	Washer, 3 x 2	4	
9	91178	Retaining Ring	1	
10	272620B	Plate-Hose Bracket	1	
11	9003816	Poly Clamp Pair (0.54)	7	
12	9003814	Top Plate	6	
13	9390-037	Capscrew, 5/16-18UNC x 2 3/4 Gr.5	1	
14	9390-132	Capscrew, 5/8-11UNC x 4 Gr.5	1	
15	284691B	Bracket-Linkage	1	
16	285290	Bushing-Sleeve	3	
17	9876	Elbow, 9/16-18 JIC M/F	2	
18	285219	Pin Weldment	2	
19	9005687	Snap Ring, 1/2"	2	
20	9405-086	Flat Washer, 1/2 SAE	2	
21	284699B	Linkage Weldment	1	
22	9390-108	Capscrew, 1/2-13UNC x 3 1/4 Gr.5	1	
23	272619	Bushing-Sleeve	1	
24	268905	Bushing Spacer	2	
25	272571	Bushing-Sleeve	1	
26	9390-111	Capscrew, 1/2-13UNC x 4 Gr.5	1	
27	9390-032	Capscrew, 5/16-18UNC x 1 1/2 Gr.5	1	
28	272570B	Plate-Hose Bracket	1	
29	91263	Large Flange Nut, 3/8-16UNC	4	
30	9390-038	Capscrew, 5/16-18UNC x 3 Gr.5	2	
31	284986	Pin Weldment-Pivot, Hood	1	
32	95193	Adapter 9/16-18 JICF x 9/16-18 JICM	2	0.030 Restrictor
33	9876	90° Elbow 9/16-18 JICF x 9/16-18 JICM	2	
34	295174B	Plate-Switch Bracket	1	
35	271338B	Linkage Weldment =Black=	1	
36	9390-034	Capscrew, 5/16-18UNC x 2 Gr.5	3	
37	9007124	1 1/2" x 3" Hydraulic Cylinder	1	
38	97189	Large Flange Nut, 1/4-20UNC	2	
39	97420	Flange Screw, 1/4-20UNC x 3/4" Gr.5	2	

Brent 1196/1396 Right-Hand Unload — Parts

Switch Assembly Components (Optional)

Please visit www.unverferth.com/parts/ for the most current parts listing.

NOTE: Switch assembly components are only applicable with optional 5 spool EOH valve hydraulic block.

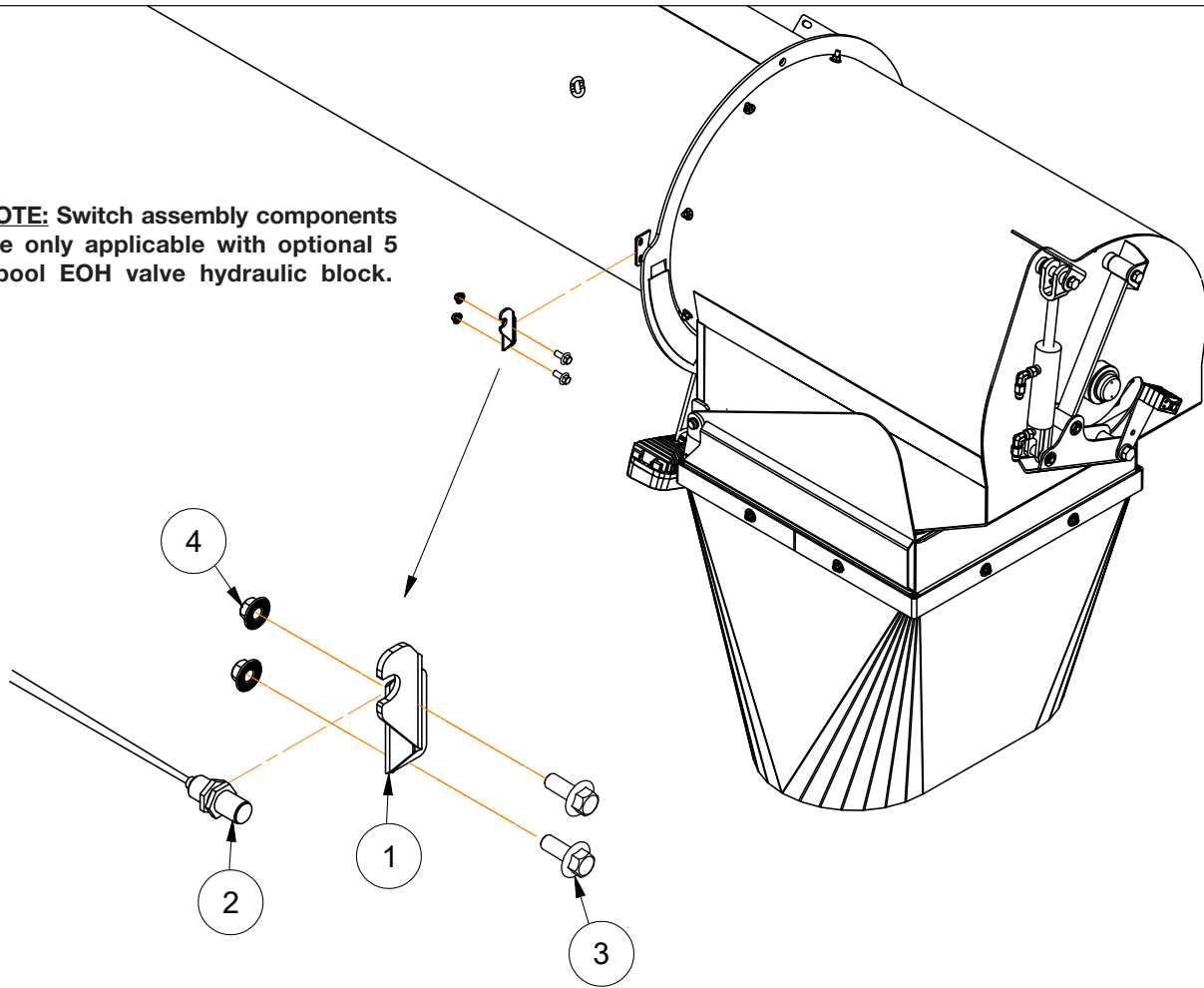

ITEM	PART NO.	DESCRIPTION	QTY	NOTES
1	295174B	Switch Plate Bracket =Black=	1	
2	9007223	Proximity Sensor with Connector	1	
3	97420	Flange Screw, 1/4-20UNC x 3/4 Gr.5	2	
4	97189	Large Flange Nut, 1/4-20UNC	2	

Brent 1196/1396 Right-Hand Unload — Parts

Notes

Please visit www.unverferth.com/parts/ for the most current parts listing.

Rotating Spout Components

Please visit www.unverferth.com/parts/ for the most current parts listing.

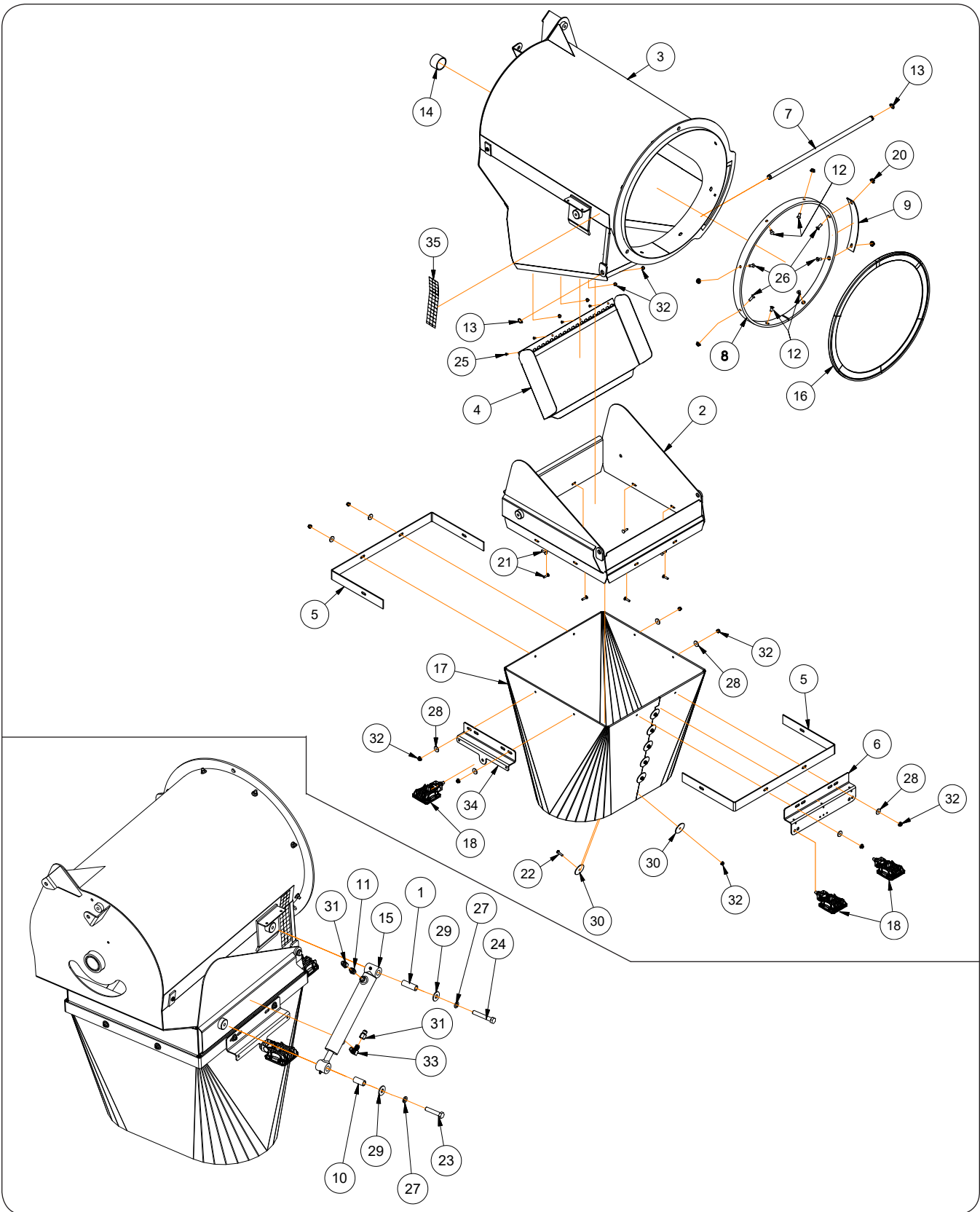

Brent 1196/1396 Right-Hand Unload — Parts

Rotating Spout Components

Please visit www.unverferth.com/parts/ for the most current parts listing.

ITEM	PART NO.	DESCRIPTION	QTY	NOTES
	295161B	Rotating Spout Assembly Less Rotating Cylinder	-	Includes Items 1 through 34
1	268571	Sleeve Bushing 3/4 Dia. x 0.532 Dia. x 2 3/8	1	
2	295163B	Spout Weldment =Black=	1	
3	295162B	Hood Weldment =Black=	1	
4	272562B	Deflector Weldment =Black=	1	
5	272565B	Strap Chute Plate =Black=	2	
6	272646B	Light Bracket =Black=	1	
7	272596	Pivot Shaft	1	
8	272599	Wear Ring	1	
9	272600B	Hood Shim Plate =Black=	1	
10	273656	Sleeve Bushing 3/4 Dia. x 0.532 Dia. x 1 11/16	1	
11	9001495	Adapter 9/16-18 JIC Male x 9/16-18 OR Male	1	
12	903171-660	Flat Countersunk Head Machine Screw 5/16"-18UNC x 1"	4	
13	9003810	External Retaining Ring 3/4"	2	
14	9005085	Self Lubricating Bushing	1	
15	9005135	Cylinder 1 1/2 x 8	1	
	9005419	Seal Kit	1	
16	9008122	Trim-Lok	7	
17	9006421	Auger Hood 22"	1	
18	9008957	Work Light LED	3	
20	91257	Hex Flange Nut 5/16-18 Grade 5	8	
21	9388-003	Carriage Bolt 1/4-20 x 1 Grade 5	8	
22	9390-005	Capscrew 1/4-20 UNC x 1 Grade 5	6	
23	9390-105	Capscrew 1/2-13 UNC x 2 1/2 Grade 5	1	
24	9390-108	Capscrew 1/2-13 UNC x 3 1/4 Grade 5	1	
25	97420	Flange Screw, 1/4-20 x 3/4 Grade 5	4	
26	903171-660	Flat Head Machine Screw 5/16-18 UNC x 1	4	
27	9404-025	Split Lock Washer, 1/2	2	
28	9405-066	Fender Washer 1/4"	8	
29	9405-088	Flat Washer 1/2 USS	2	
30	94763	Fender Washer, 2" OD x 5/16 ID	12	
31	95193	Adapter 9/16-18 JIC Female x 9/16-18 JIC Male	2	
32	97189	Large Hex Flange Nut 1/4-20 UNC Grade 5	18	
33	97445	Elbow 90° 9/16-18 JIC Male x 9/16-18 OR ADJ Male	1	
34	272841B	Light Bracket =Black=	1	
35	265384	Checker Decal	2	

Brent 1196/1396 Right-Hand Unload — Parts

Cut Out Clutch PTO Assembly

Please visit www.unverferth.com/parts/ for the most current parts listing.

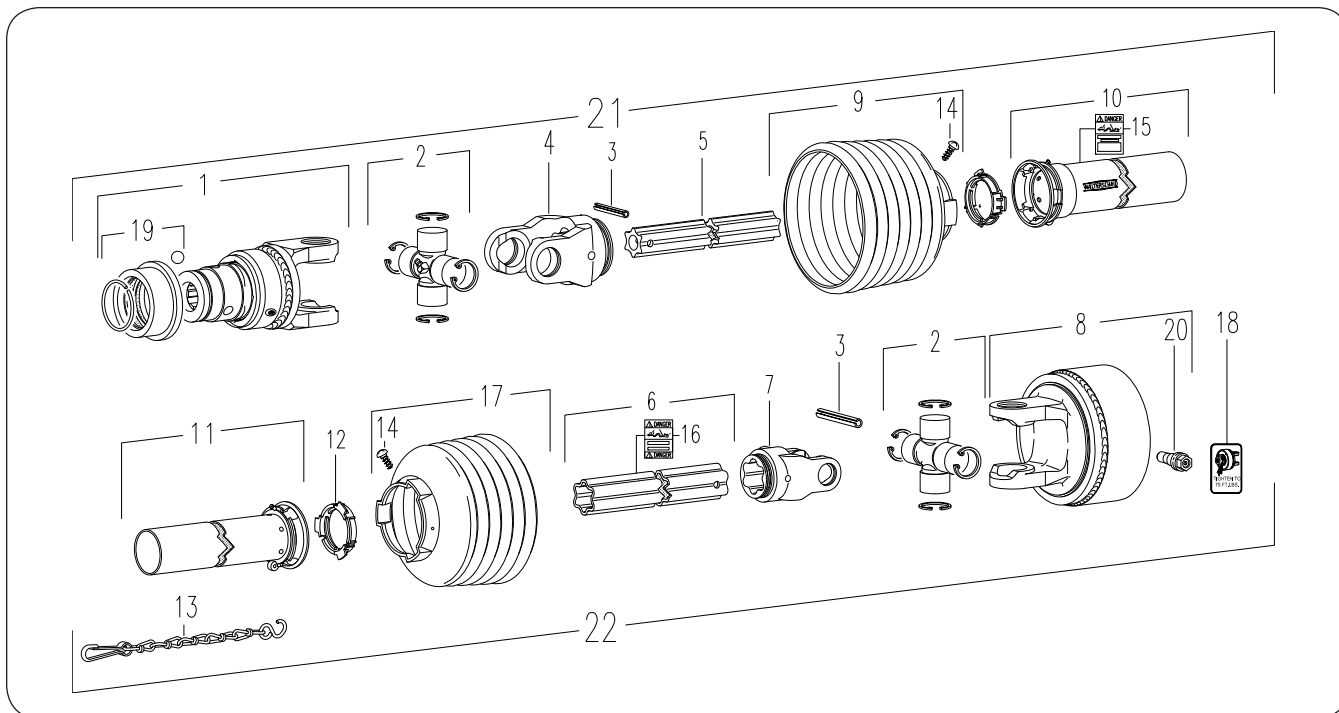

ITEM	PART NO.	DESCRIPTION	QTY	NOTES
	9005230	PTO Assembly Complete		Includes Items 19 & 20
1	9005234	Over-Running PTO Clutch Assembly	1	
2	92529	Cross & Bearing Kit	2	
3	9002609	Spring Pin 10x90	2	
4	9002610	Inboard Yoke S4	1	
5	9004840	Inner Profile	1	
6	9004841	Outer Profile	1	
7	9002613	Inboard Yoke S5	1	
8	9005235	Cut Out Clutch (3200 N-m Setting)	1	1 3/4-20 Spline 1000RPM
9	9002615	Shield Cone 7 Rib	1	
10	9004843	Outer Shield Tube Oval	1	
11	9004844	Inner Shield Tube Oval	1	
12	92373	Bearing Ring	2	
13	92374	Safety Chain	1	
14	92372	Screw	2	
15	92377	Decal Out	1	
16	92378	Decal In	1	
17	93866	Shield Cone 6 Rib	1	
18	9005233	Decal K64	1	"Tighten to 75 Ft.-Lbs."
19	93856	Quick-Disconnect Kit	1	1 3/4-20 Spline w/Metal Collar
20	9005253	Cut Out Clutch Lock Assembly	1	
21	9005231	PTO Front Half Assembly 1 3/4-20 Spline	1	
22	9005232	PTO Rear Half Assembly 1 3/4-20 Spline	1	
23	9002513	Reinforcing Collar	1	NOT SHOWN

Cut Out Clutch Components

Please visit www.unverferth.com/parts/ for the most current parts listing.

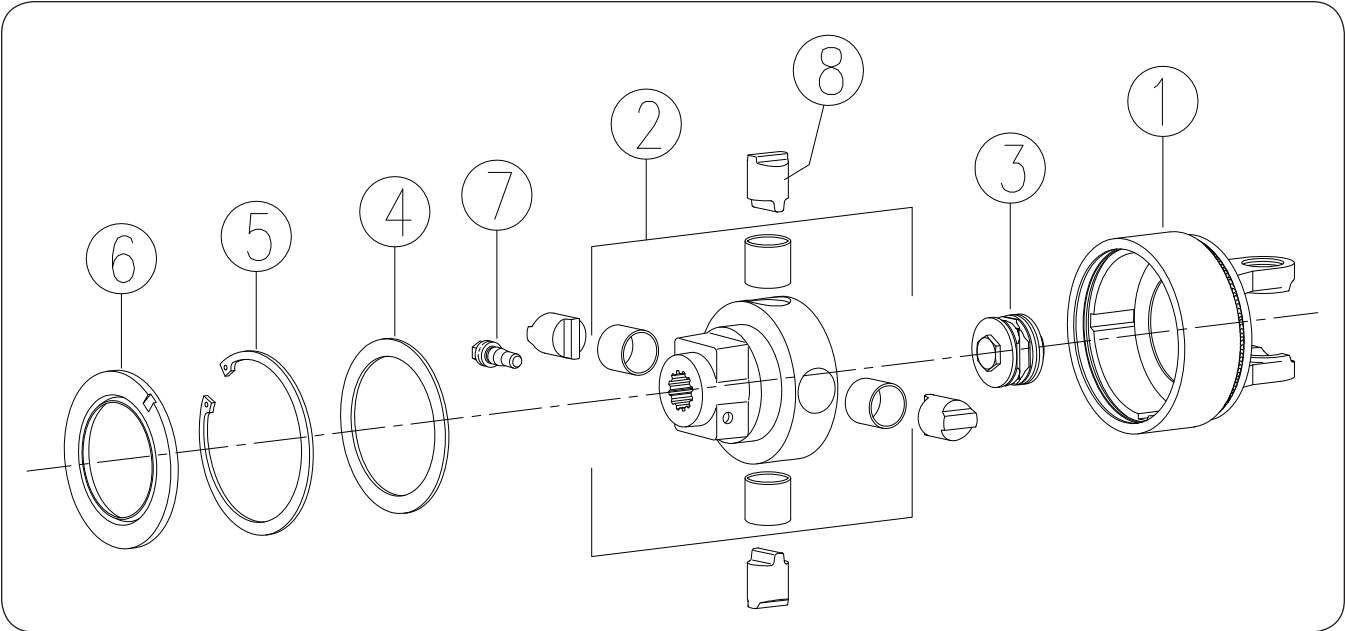

NOTE: Cut Out Clutch (9005235) must be used with the Complete PTO Assembly (9005230). This will not work with the Friction Clutch PTO Assembly (9005245).

ITEM	PART NO.	DESCRIPTION	QTY	NOTES
	9005235	Cut Out Clutch (3200 N*m Setting)		Includes Items 1-8
1	9005247	Clutch Housing	1	
2	9005248	Clutch Hub 1 3/4-20 Spline	1	
3	9005249	Spring Pack	1	
4	9005250	Washer	1	
5	9005251	Retaining Ring	1	
6	9005252	Sealing Ring	1	
7	9005253	Clutch Clamp Cone Assembly	1	
8	9005254	Clutch Cam	4	

Brent 1196/1396 Right-Hand Unload — Parts

Gearbox Components

Please visit www.unverferth.com/parts/ for the most current parts listing.

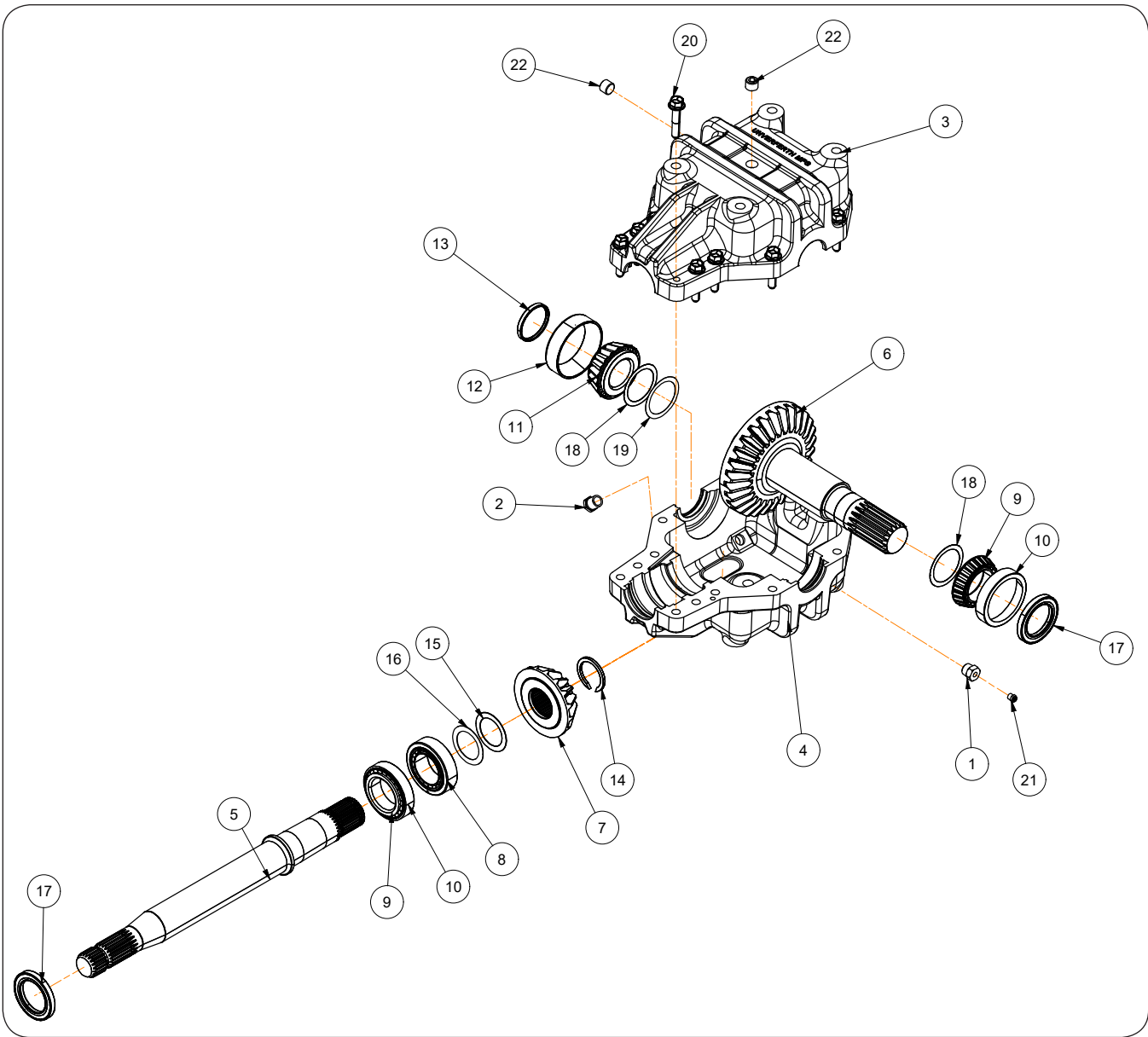

Brent 1196/1396 Right-Hand Unload — Parts

Gearbox Components

Please visit www.unverferth.com/parts/ for the most current parts listing.

ITEM	PART NO.	DESCRIPTION	QTY	NOTES
	9009060	Gearbox Complete	1	Includes Items 1 through 22
1	9003453	Reducer Bushing, 1/2-14 NPTF M x 1/8-27 NPTF F	1	
2	9006381	Glass Sight Plug	1	
3	9009431	Gearbox Housing Q800 w/Tapped Holes	1	
4	9009430	Gearbox Housing Q800 w/Through Holes	1	
5	9007494	Gearbox Shaft 2 1/4" Dia.	1	
6	9007495	Gear Shaft Assembly 29 Tooth, 2 1/4-17 Spline	1	
7	9007496	Gear 16 Tooth Splined	1	
8	9007497	Bearing Cup & Cone Set, 3.740 OD x 1 1/4	1	
9	9007498	Bearing Cone 2 1/4 ID x 1	2	
10	9007499	Bearing Cup 3.8437 OD x 0.7812	2	
11	9007500	Bearing Cone 2 ID x 1.5312	1	
12	9007501	Bearing Cup 4.125 OD	1	
13	9007502	End Cap	1	
14	9007503	Retaining Ring - External 2" Nominal Shaft Dia.	1	
15	9007504	Shim - 0.025	1	
16	9007505	Shim - 0.030	1	
17	9007508	Shaft Seal	2	
18	9007511	Shim - 0.005	2	
19	9007512	Shim - 0.003	1	
20	903161-060	Flange Screw 1/2-13UNC x 2 1/2	12	
21	92352	Pressure Relief	1	
22	95283	Plug	3	

Indicator Assembly

Please visit www.unverferth.com/parts/ for the most current parts listing.

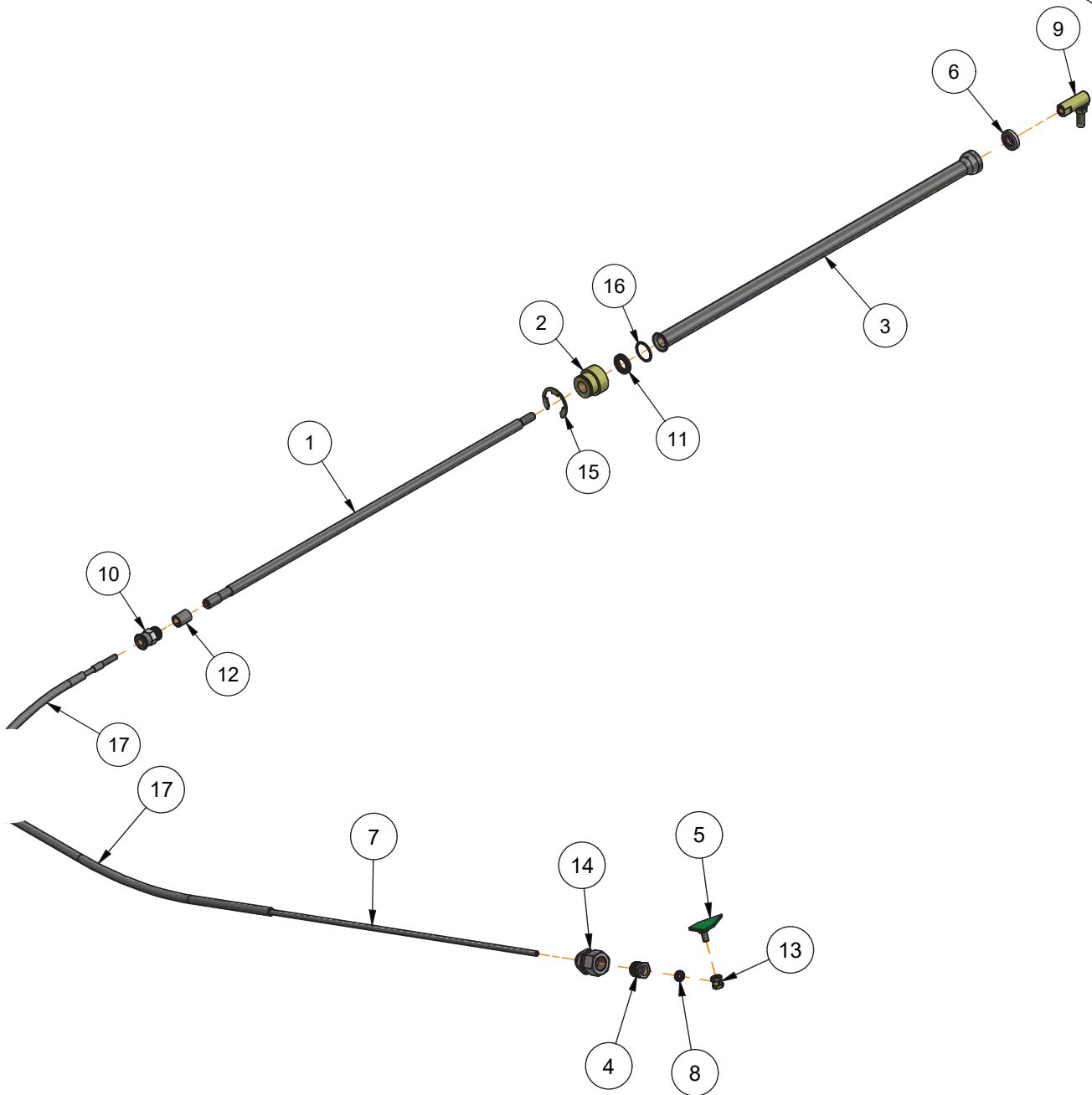

Assembled View

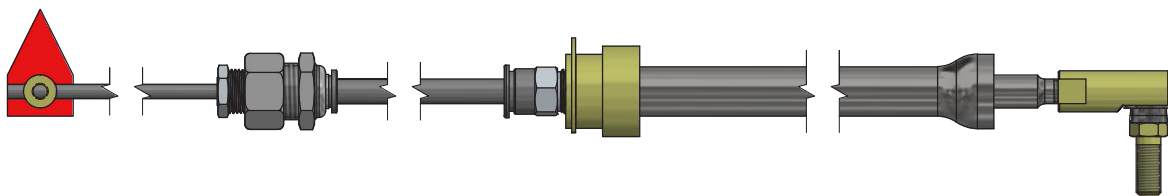

Brent 1196/1396 Right-Hand Unload — Parts

Indicator Assembly

Please visit www.unverferth.com/parts/ for the most current parts listing.

ITEM	PART NO.	DESCRIPTION	QTY	NOTES
	271584	Complete Indicator Assembly	1	Includes Items 1 through 17
1	271582	Push Rod Indicator	1	
2	271585	Bushing - Coupler	1	
3	271589	Cable Tube (Push Rod)	1	
4	271593	Reducer Bushing	1	
5	271595R	Flow Door Indicator =Red=	1	
6	9006610	Seal (Wiper)	1	
7	9006611	Inner Cable (Conduit) - 3/16	1	
8	9008612	Seal (Shaft)	1	
9	9006630	Rod End, 3/8"	1	
10	9006634	Connector Fitting	1	
11	9006635	Quad Ring	1	
12	9006636	Wear Ring	1	
13	271597	Wire Stop	1	
14	9006640	Hose Fitting	1	
15	9006641	Snap Ring	1	
16	9006644	Retaining Ring - Internal	1	
17	271586	Plastic Tubing - 81"	1	

Hopper Rear Electrical Components

Please visit www.unverferth.com/parts/ for the most current parts listing.

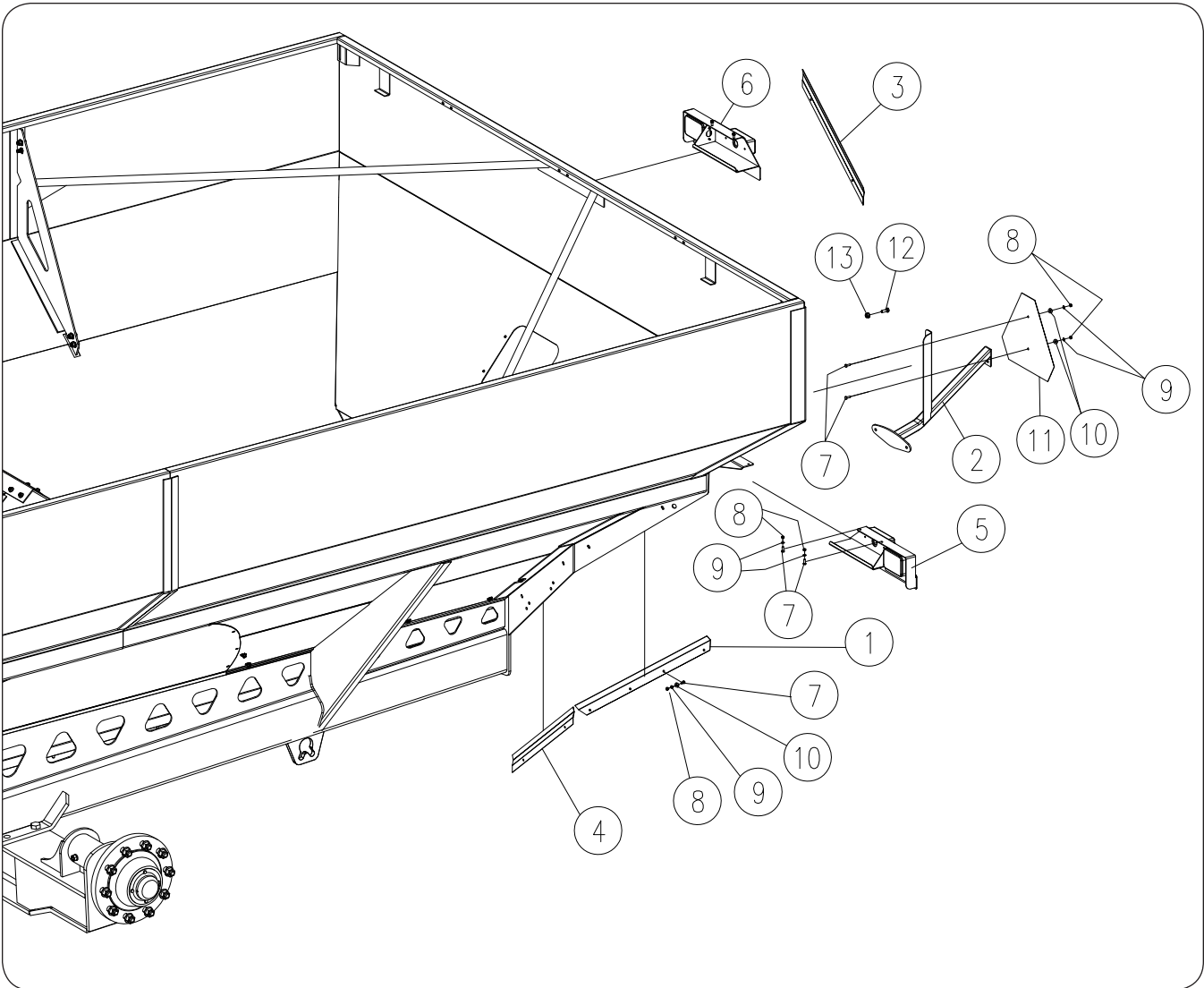

Hopper Rear Electrical Components

Please visit www.unverferth.com/parts/ for the most current parts listing.

ITEM	PART NO.	DESCRIPTION	QTY	NOTES
1	282305G	Upper Harness Cover =Green=	1	
	282305R	Upper Harness Cover =Red=		
2	221696B	SMV Bracket	2	
3	282308G	Harness Cover Plate RH =Green=	3	
	282308R	Harness Cover Plate RH =Red=		
4	282309G	Harness Cover Plate LH =Green=	4	
	282309R	Harness Cover Plate LH =Red=		
5	284358B	Lamp Assembly LH	5	
6	284359B	Lamp Assembly RH	6	
7	9390-003	Capscrew 1/4-20UNC x 3/4 Grade 5	7	
8	9394-002	Hex Nut 1/4-20UNC Grade 5	8	
9	9404-017	Lock Washer 1/4"	9	
10	9405-064	Flat Washer 1/4"	10	
11	9829	SMV Emblem	11	
12	9390-003	Capscrew, 1/4-20UNC x 3/4 Grade 5	12	
13	97189	Large Flange Hex Nut, 1/4-20UNC Grade 5	13	

Brent 1196/1396 Right-Hand Unload — Parts

Electrical Components - 5 Function Control Grip

Please visit www.unverferth.com/parts/ for the most current parts listing.

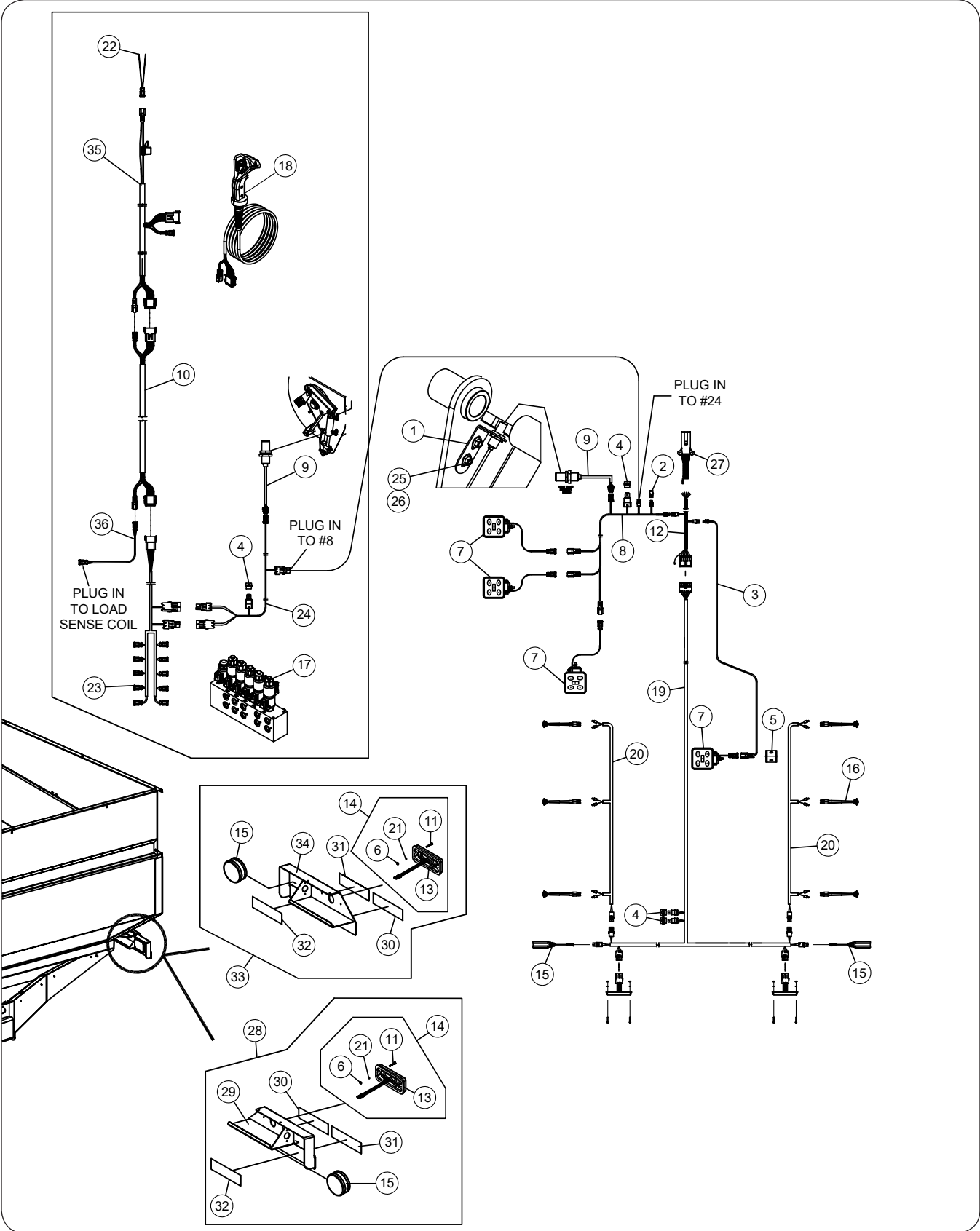

Brent 1196/1396 Right-Hand Unload — Parts

Electrical Components - 5 Function Control Grip

Please visit www.unverferth.com/parts/ for the most current parts listing.

ITEM	PART NO.	DESCRIPTION	QTY	NOTES
1	272645B	Switch Plate Bracket =Black=	1	
2	252386	Plug Assembly, 2 Pin Shroud	1	
3	9008969	Wiring Harness - 226"	1	
4	9005618	Relay - 12VDC	4	
5	271574B	Lamp Mount Plate =Black=	1	
6	9830-016	Hex Nut, #10-32	4	Grade 2
7	9008957	Work Light (LED)	4	
8	9008956	Switch Wiring Harness - 300"	1	
9	9007223	Proximity Switch	2	
10	9008252	Joystick Controller Extension Harness	1	
11	903172-350	Phillips Pan Head Screw, #10-32UNF x 1-1/4"	4	
12	9008501	Front Harness - 296"	1	
13	9006282	LED Lamp - Red	2	
14	232170	LED Lamp - Red - Replacement Kit	2	Includes Lamp, & Items 6, 11, 13 & 21
15	9005142	LED Lamp - Amber	2	
16	9006107	Micro Dot, LED Amber Light	6	
17	293416	EOH Block Assembly - 5 Spool Replacement Kit	1	
18	9008265	L-Series Control Grip - 5 Function	1	
19	9006480	Rear Harness	1	
20	9006520	Clearance Harness	2	
21	9404-013	Lock Washer, #10	4	
22	9006907	Power Harness, 2-Pin	1	
23	9007290	"T" Main Wiring Harness - 189"	1	
24	9007286	Wiring Harness - 205" EOH for Proximity Switch	1	
25	91262	Large Flange Screw, 3/8-16 x 1	2	Grade 5
26	91263	Large Flange Nut, 3/8-16UNC	2	Grade 5
27	92450	7-Way Plug	1	
28	284358B	Lamp Assembly Left-Hand	1	Includes items 14, 15, 29, 30, 31, 32
29	284370B	Lamp Mount Weldment Left-Hand	1	
30	9003125	Reflector 2 x 9 Fluorescent - Red / Orange	2	
31	9003126	Reflector 2 x 9 =Red=	2	
32	9003127	Reflector 2 x 9 = Amber=	2	
33	284359B	Lamp Assembly Right-Hand	1	Includes Items 14, 15, 30, 31, 32, 34
34	284371B	Lamp Mount Weldment Right-Hand	1	
35	9008251	Harness - Joystick Power	1	
36	9007266	Wire Harness, 218 5/16" (2 Pin Diverter)	1	

Brent 1196/1396 Right-Hand Unload — Parts

Weather Guard Tarp

Please visit www.unverferth.com/parts/ for the most current parts listing.

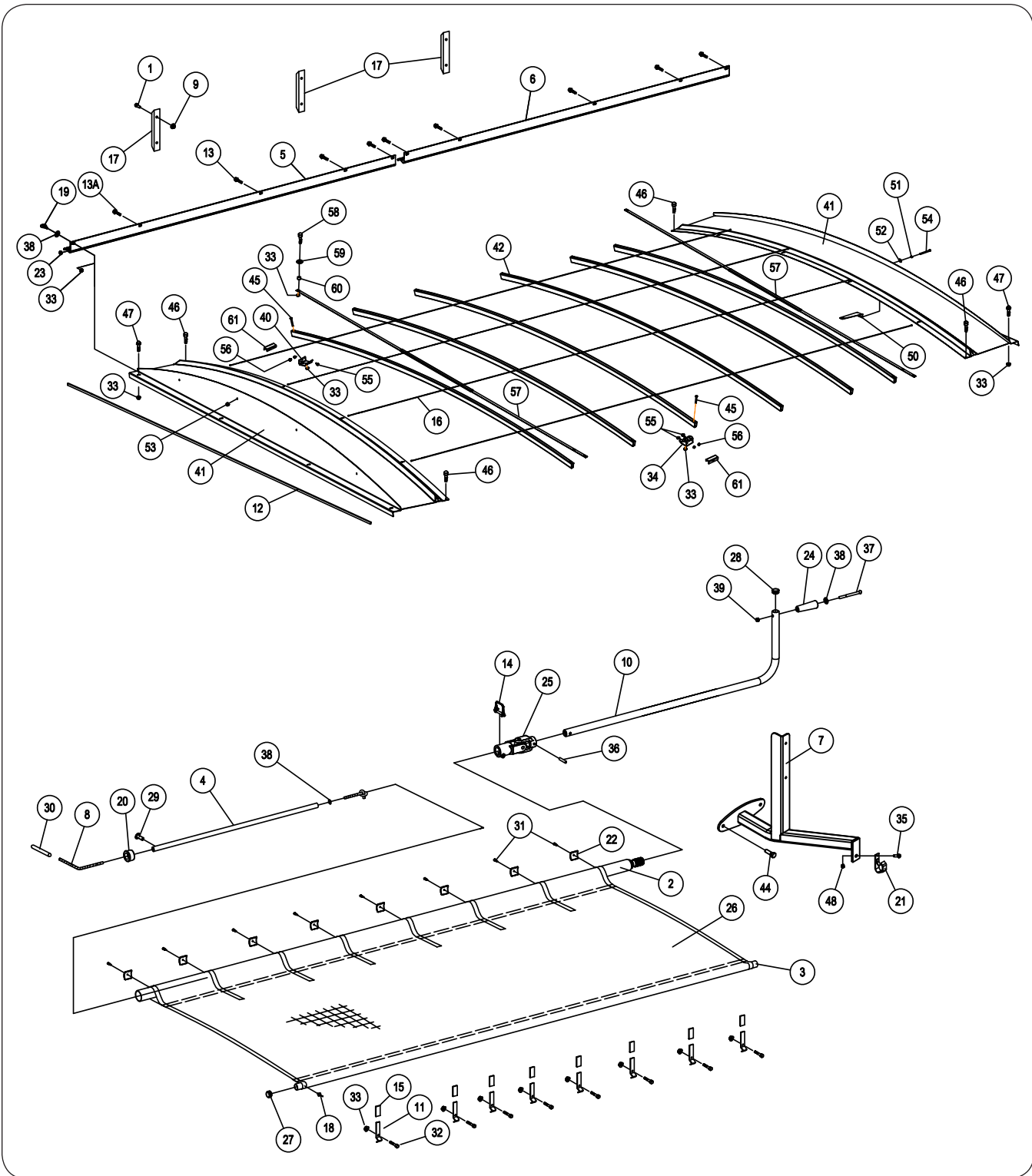

ITEM	PART NO.	DESCRIPTION	QTY	NOTES
	255001-MOD	Tarp Kit	-	
1	9004355	Screw 1/4-20UNC x 1 Self-Threading	6	Model 1196 Only
2	221788	Roll Tube Weldment	1	
3	221614	Fixed Tube Weldment	1	
4	221668	Pipe - 180"	1	

Brent 1196/1396 Right-Hand Unload — Parts

Weather Guard Tarp

Please visit www.unverferth.com/parts/ for the most current parts listing.

ITEM	PART NO.	DESCRIPTION	QTY	NOTES
5	221678	Plate - Latch 129 1/2" (Front)	1	
6	221679	Plate - Latch 129 1/2" (Rear)	1	
7	221696B	Handle Bracket Weldment	1	
8	221722	Bungee 3/8" Dia. x 204"	1	
9	97189	Hex Nut/Large Flange 1/4-20UNC	6	Model 1196 Only
10	221749	Tarp Handle Weldment	1	
11	266689B	Tarp Short Stop Plate	6	
12	9000787	Trim-lok	A/R	
13	9005312	Torx Head Machine Screw 3/8-16UNC x 1 Grade 5	8	
13A	9009089	Torx Head Machine Screw 3/8-16UNC x 1 1/4 Grade 5	1	
14	9005305	Lynch Pin 3/8" x 3"	1	
15	9003078	Cap - Plastic (2 x 3)	4	
16	9005676	Cable Assembly	4	
17	9005307	Poly Deflector 8"	3	Model 1196 Only
18	9003378	Rivet/Pop 3/16"	2	
19	9004548	Eye Bolt 3/8-16UNC x 1 3/4	1	
20	9004947	Plug 2"	1	
21	221770B	Handle Retainer Weldment	1	
22	9004949	U-Clamp	8	
23	9004968	Plug 1"	2	
24	9004969	Handle	1	
25	9004977	U-Joint w/ 1 3/8-21 Spline	1	
26	9005045	Tarp 166 x 253	1	
27	9005088	Plug 1 1/8	2	
28	9005089	Plug 1 1/4	1	
29	9001396	Pan Head Screw #10-16 x 1/2"	1	
30	TA806225	Hose 1/2 EPDM	1	
31	9005197	Screw/Self Drilling #10-16 x 3/4 Pan Head	8	
32	91262	Screw/Large Flange 3/8-16UNC x 1	4	Grade 5
33	91263	Nut/Large Flange 3/8-16UNC	33	Grade 5
34	283427B	Tarp Bow Bracket =Black= (Left Hand Side)	6	
35	9390-055	Capscrew 3/8-16UNC x 1	1	Grade 5
36	9392-180	Roll Pin 3/8" Dia. x 2"	1	
37	903172-450	Phillips Machine Screw Pan Head 3/8"-16UNC x 4 1/2"	1	
38	9405-074	Flat Washer 3/8	3	
39	9398-012	Elastic Stop Nut 3/8-16UNC	1	
40	283425B	Tarp Bow Bracket =Black= (Right Hand Side)	6	
41	281713B	End Cap Weldment	2	
42	283424B	Tarp Bow Weldment	6	
44	9390-056	Capscrew 3/8-16UNC x 1 1/4	2	Grade 5
45	902703-046	Flat Socket Countersunk Capscrew 3/8"-16UNC x 3" (RH Thread)	12	Grade 5
46	9512	Screw/Self Drilling 1/4-14 x 1	4	
47	95585	Capscrew/Large Flange 3/8-16UNC x 3/4	8	Grade 5
48	9928	Locknut 3/8-16UNC	1	
49	9005581	Tarp Patch Kit	1	Not Shown
50	281712B	Bracket and U-Nut Asy	4	
51	9005688	Star Washer	4	
52	9005696	Fender Washer	4	
53	9005727	Plug	4	
54	TA0-907131-0	Capscrew 3/8-16UNC x 4 1/2 (Full Threaded)	4	
55	97604	Flange Screw 5/16"-18UNC x 1" Grade 5	24	
56	91257	Hex Nut/Large Flange 5/16"-18UNC	24	
57	9008948	Hurricane Strap For 12 FT Wide Hopper	2	
58	96972	Screw/Self Tapping 3/8"-16UNC x 1"	2	
59	9008972	Flat Washer, 3/8" Aluminum	4	
60	9008949	Tarp Strap Spacer Bushing	4	
61	294660B	Sideboard Doubler =Black=	12	

Brent 1196/1396 Right-Hand Unload — Parts

Hydraulic Jack - Kit #294142B (Optional)

Please visit www.unverferth.com/parts/ for the most current parts listing.

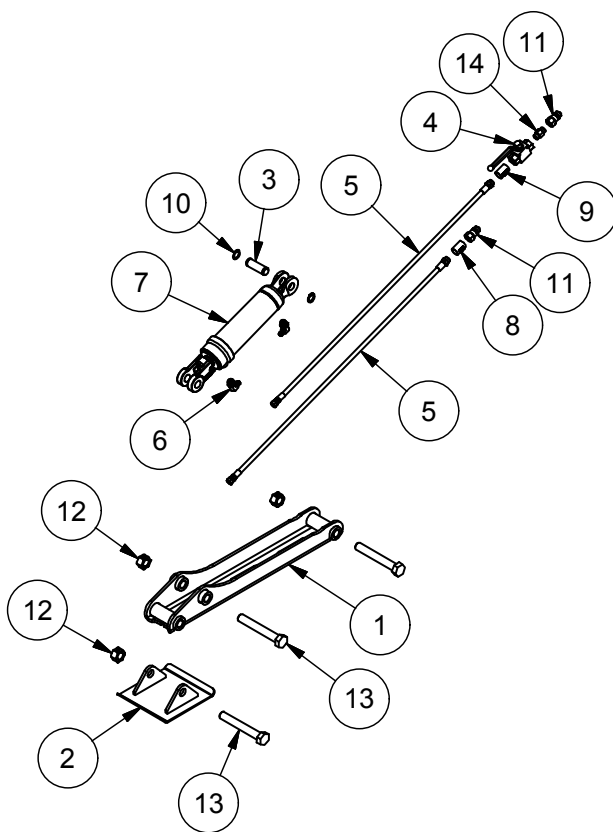

ITEM	PART NO.	DESCRIPTION	QTY	NOTES
1	271712B	Jack Weldment =Black=	1	
2	271723B	Jack Foot Weldment =Black=	1	
3	272587	Pin, 1" Dia. x 3 1/8	1	
4	9005426	High Pressure Ball Valve	1	
5	9006068	Hydraulic Hose, 1/4 x 92" - 3000 PSI	2	
6	9006173	Elbow, 90°	2	
7	9009047	Hydraulic Cylinder, 3 x 8 - 3000 PSI	1	
8	9008600	Hose Grips - Black (Pair) - Raise Jack	1	Half Black/Half Gray - Cylinder Retracted
9	9008600	Hose Grips - Black (Pair) - Lower Jack	1	Solid Black - Cylinder Extended
10	91192	Retaining Ring, 1"	2	
11	91383	Male Tip Coupling	2	
12	92199	Center Locknut, 1-8UNC	3	
13	9390-197	Capscrew, 1-8UNC x 7 Grade 5	3	
14	98508	Adapter, 3/4-16 OR Male x 3/4-16 OR Male	1	

Video System (Optional)

Please visit www.unverferth.com/parts/ for the most current parts listing.

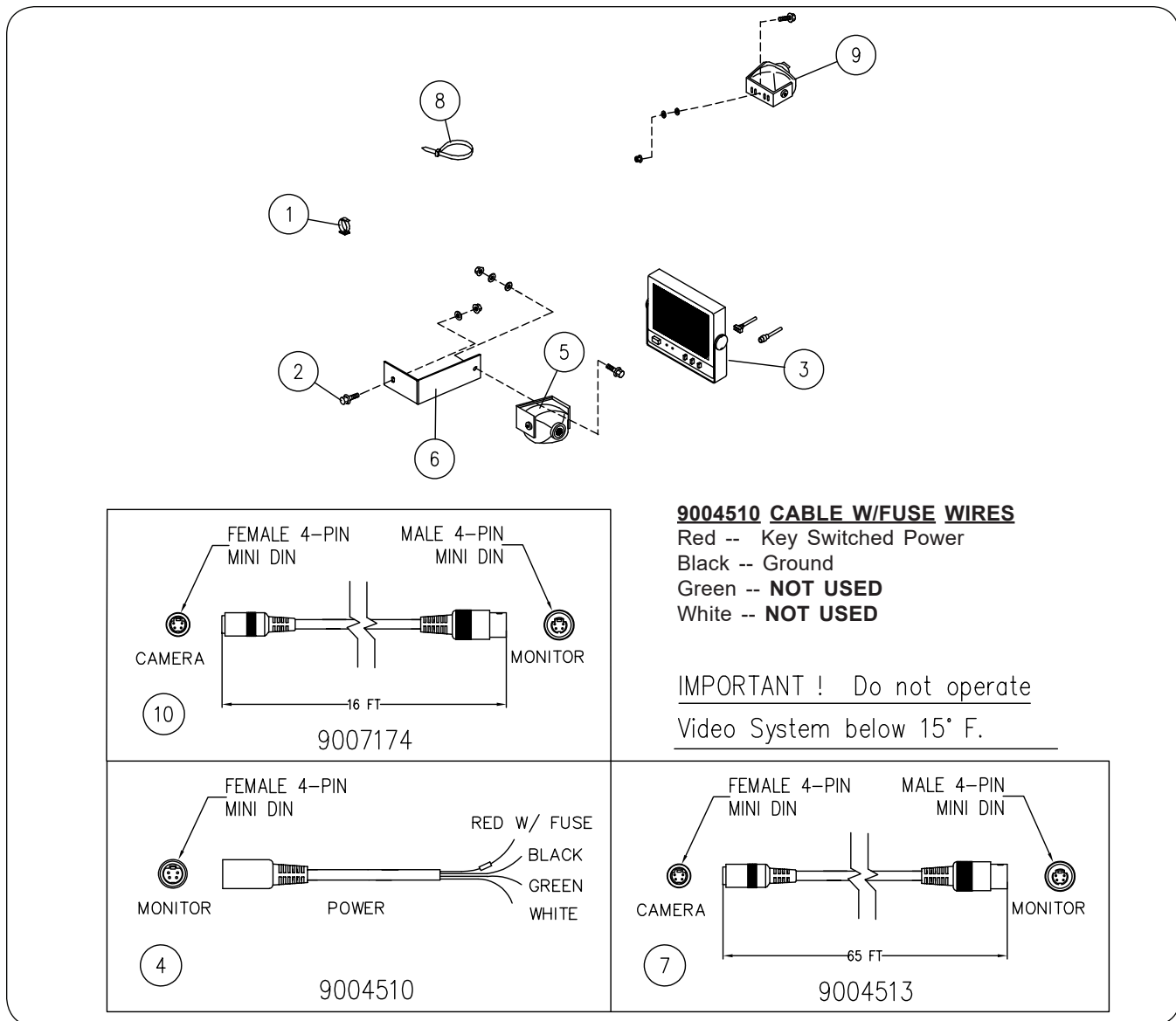

ITEM	PART NO.	DESCRIPTION	QTY	NOTES
	265770	Video System Kit with Single Camera	1	Includes Items 1 - 8 and own Instruction Sheet
	9004506	Additional Video System Kit	1	Includes Items 6 & 7
1	TAAU14007	Snap Clip, Adhesive	10	
2	9512	Self-Drilling Screw 1/4-14 x 1	10	
3	9006273	Monitor, 7" LCD/LED	1	
4	9004510	Cable w/Fuse	1	
5	9006274	Camera	1	
6	265771B	Bracket	1	
7	9004513	Cable, 65'	1	
8	9000106	Cable Tie	AR	
9	9004506	Camera Kit for Rear View with 65' Cable	1	
10	9007174	Extension Cable 16 ft. For CH Series Camera	1	



Unverferth[®]
Manufacturing Company, Inc.

www.unverferth.com